

DOD Electronics Corp.
 8760 South Sandy Parkway
 Sandy, Utah 84070

Title
 VALVE FX MAIN, IN/COMP/DETECTOR 80-6190

Size B Document Number 056190A1.002 Rev A1

Date: Tuesday, December 19, 2000 Sheet 2 of 7

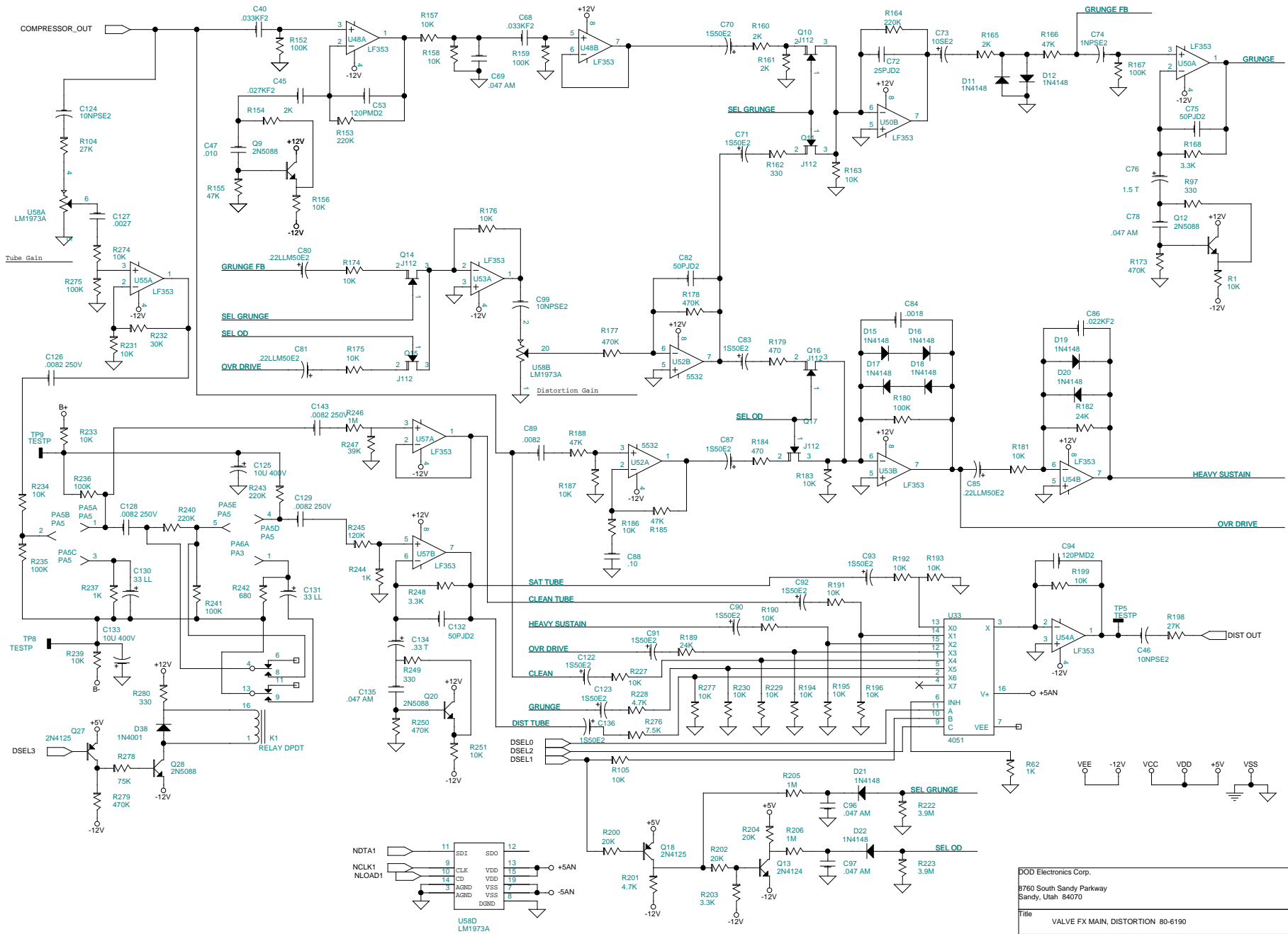

DOD Electronics Corp.
 8760 South Sandy Parkway
 Sandy, Utah 84070

Title
 VALVE FX MAIN, DISTORTION 80-6190

Size B Document Number 056190A1.003 Rev A1

Date: Tuesday, December 19, 2000 Sheet 3 of 7

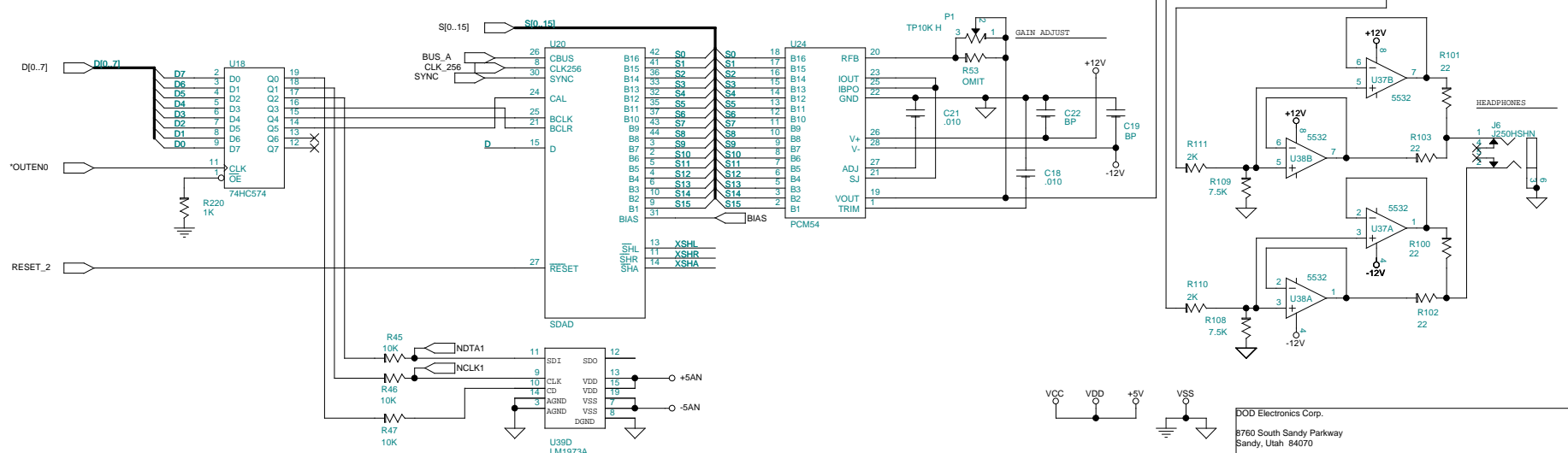
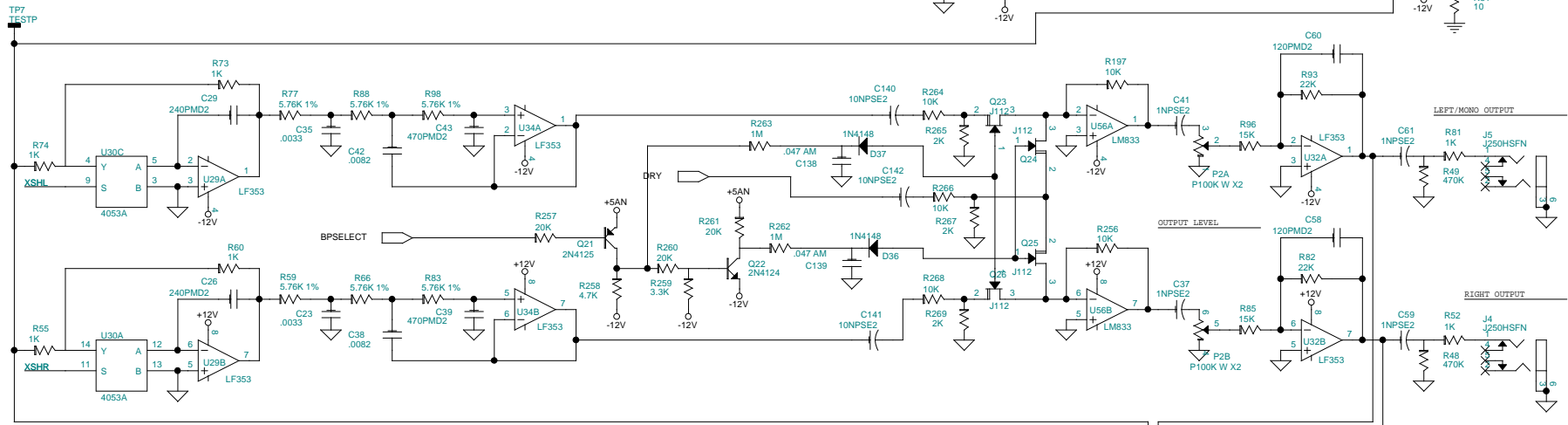
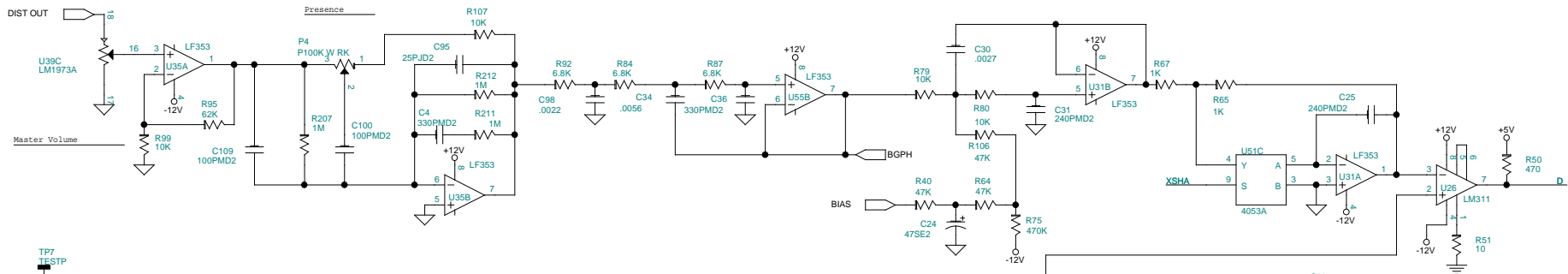

DOD Electronics Corp.
 8760 South Sandy Parkway
 Sandy, Utah 84070

Title		VALVEFX MAIN, A/D/A, OUTPUT 80-6190
Size B	Document Number	056190A1.004
Date:	Tuesday, December 19, 2000	Sheet 4 of 7

Rev A1

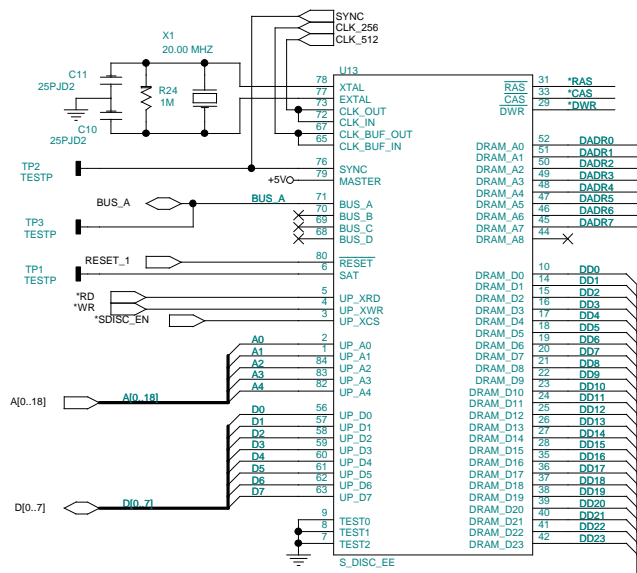

- 31 *RAS
- 33 *CAS
- 29 *DWR
- 52 DADR0
- 51 DADR1
- 50 DADR2
- 49 DADR3
- 48 DADR4
- 47 DADR5
- 46 DADR6
- 45 DADR7
- 44 DADR8
- 10 DD0
- 14 DD1
- 15 DD2
- 16 DD3
- 17 DD4
- 18 DD5
- 19 DD6
- 20 DD7
- 21 DD8
- 22 DD9
- 23 DD10
- 24 DD11
- 25 DD12
- 26 DD13
- 27 DD14
- 28 DD15
- 35 DD16
- 36 DD17
- 37 DD18
- 38 DD19
- 39 DD20
- 40 DD21
- 41 DD22
- 42 DD23

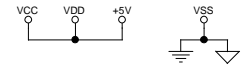
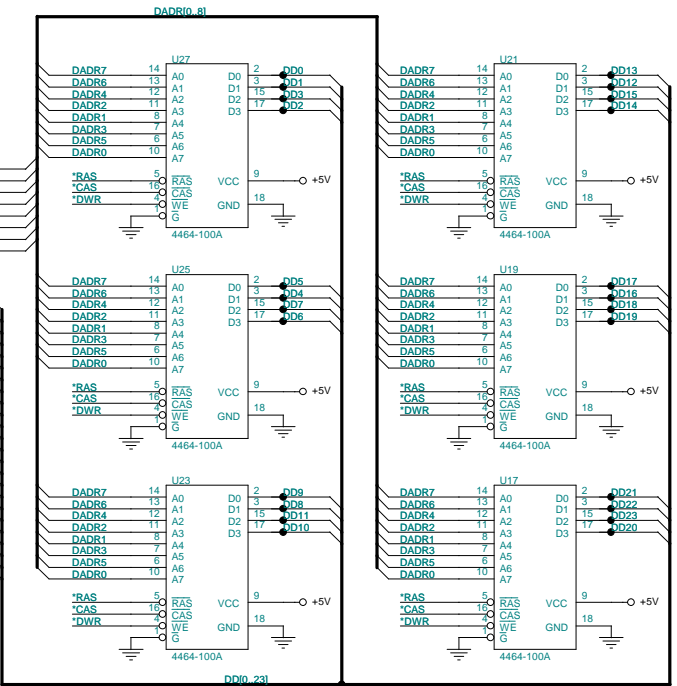

DOD Electronics Corp.		
8760 South Sandy Parkway Sandy, Utah 84070		
Title VALVE FX MAIN DSP, DRAM 80-6190		
Size B	Document Number 056190A1.005	Rev A1
Date:	Tuesday, December 19, 2000	Sheet 5 of 7

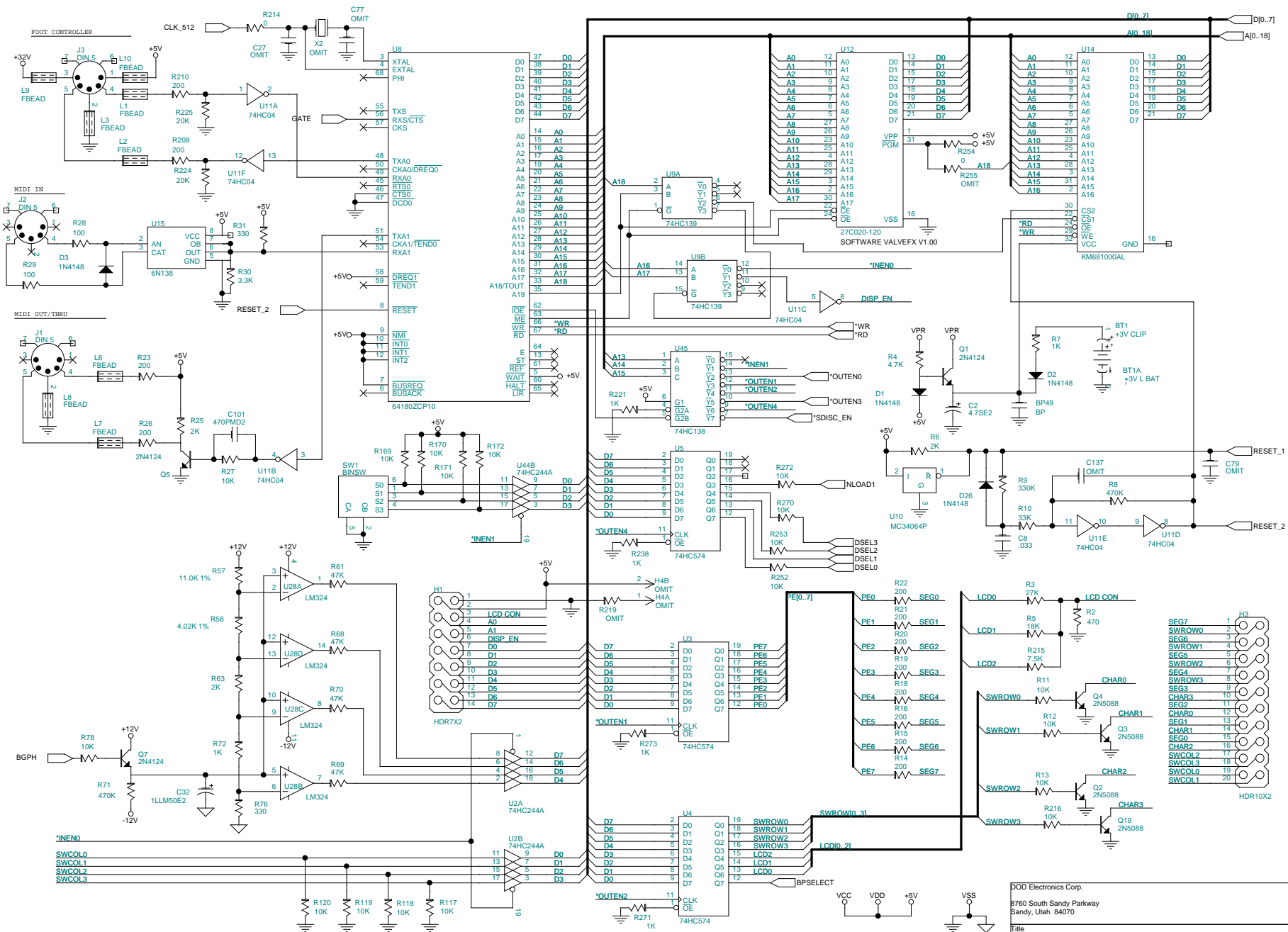

DOD Electronics Corp.
 #760 South Sandy Parkway
 Sandy, Utah 84070

Title: VALVE FX MAIN LOGIC, MIDI 80-6190

Size B Document Number 056190A1.006 Rev A1

Date: Tuesday, December 19, 2000 Sheet 6 of 7

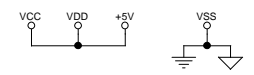
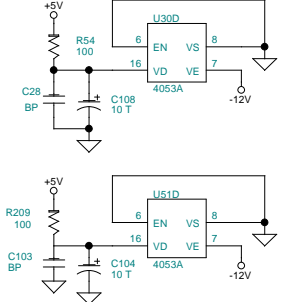
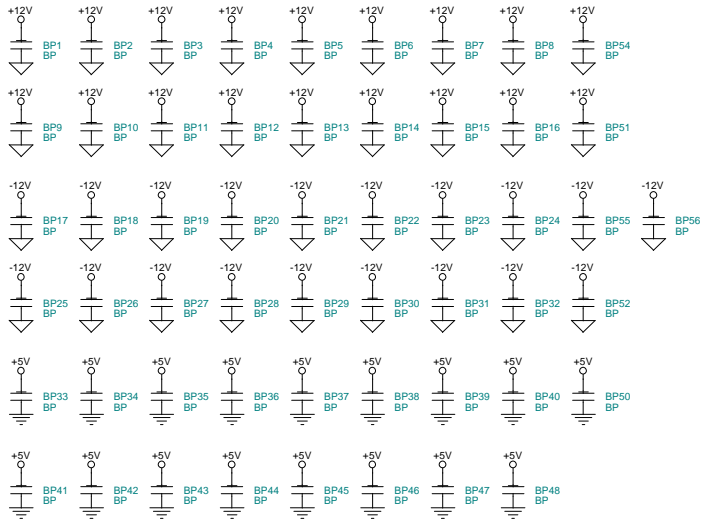
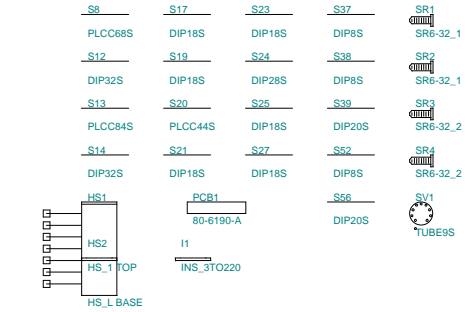
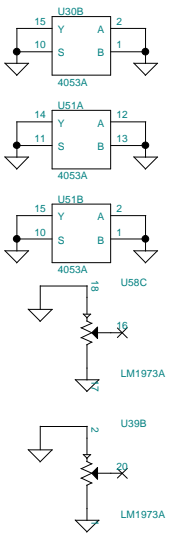
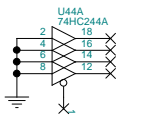
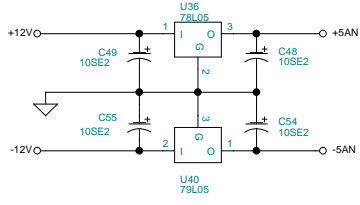
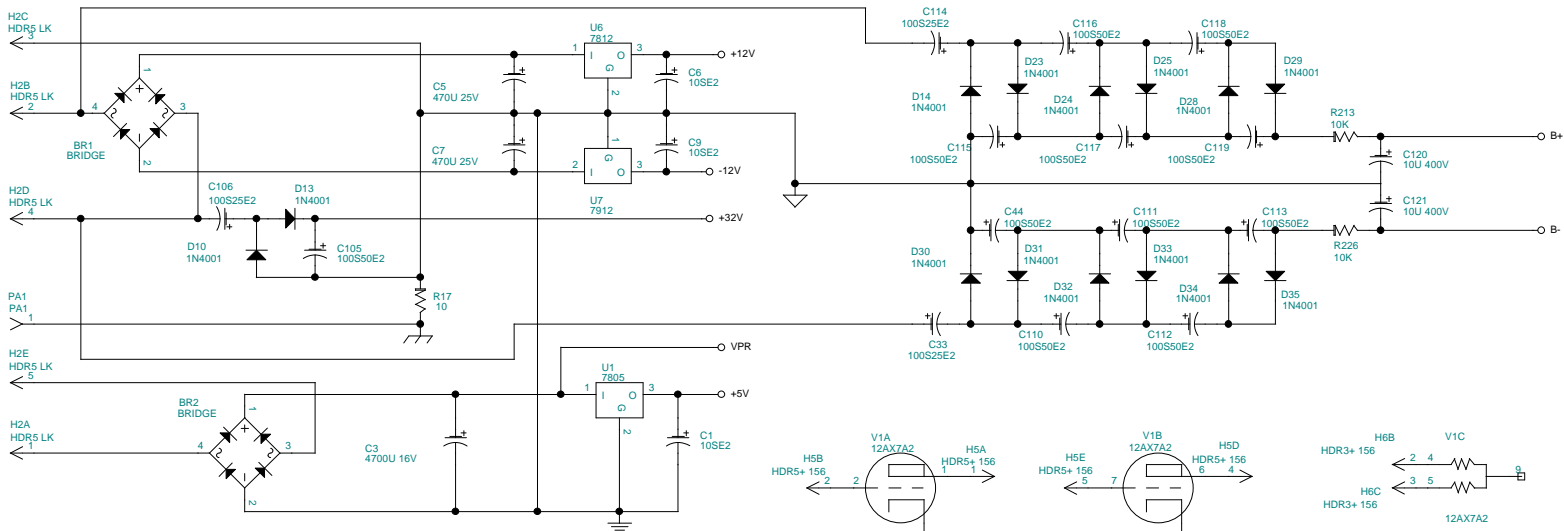

- LAST REF.
 BP51
 BR1
 BR2
 C110
 D26
 HS2
 I1
 J8
 L10
 P4
 Q25
 R239
 RN1
 S86
 SW1
 T57
 U56
 X2

DOD Electronics Corp.
 8760 South Sandy Parkway
 Sandy, Utah 84070

Title: VALVE FX MAIN, POWER 80-6190

Size B	Document Number 056190A1.007	Rev A1
--------	------------------------------	--------

Date: Tuesday, December 19, 2000 Sheet 7 of 7

&l0 (sOP (s15H (s8V (s0S &l6D &l66P &l3E &a7L &a120M &l61FDOD Software

Page 1

REVISION HISTORY FOR 05-6190

Revised: September 22, 1994

056190A1.001

Revision: A1

Bill Of Materials

September 22, 1994

9:35:20

Quan Reference

Part

SYMAN

Description

Quan	Reference	Part	SYMAN	Description
59	BP1, BP2, BP3, BP4, BP5, BP6, BP7, BP8, BP9, BP10, BP11, BP12, BP13, BP14, BP15, BP16, BP17, BP18, BP19, C19, BP20, BP21, BP22, C22, BP23, BP24, BP25, BP26, BP27, BP28, C28, BP29, BP30, BP31, BP32, BP33, BP34, BP35, BP36, BP37, BP38, BP39, BP40, BP41, BP42, BP43, BP44, BP45, BP46, BP47, BP48, BP49, BP50, BP51, BP52, BP54, BP55, BP56, C103	BP	62-0067	0.047 uF Capacitor 20% 50V Axial Monolithic
2	BR1, BR2	BRIDGE	70-0129	Bridge Rectifer
1	BT1	+3V CLIP	24-1014	Holder For 3V Battery
1	BT1A	+3V L BAT	24-1016	3V Battery, Lithium, Eveready Part #CR2032
8	C1, C6, C9, C48, C49, C54, C55, C73	10SE2	60-1006	10.0 uF Capacitor -20%,+80% 16V Electrolytic AMMO
2	C2, C51	4.7SE2	60-1005	4.7 uF Capacitor -20%,+80% 16V Electrolytic-A
1	C3	4700U 16V	60-0062	4700.0 uF Capacitor -20%,+80% 16V Electrolytic
2	C4, C36	330PMD2	62-3013	"OBS" 330 pF Capacitor 20% 50V Ceramic Disc -A
2	C5, C7	470U 25V	60-0058	470.0 uF Capacitor -20%,+80% 25V Electrolytic
1	C8	.033	56-2027	0.033 uF Capacitor 10% 100V Polyester Film
4	C10, C11, C72, C95	25PJD2	62-3000	"OBS" 25 pF Capacitor 5% 50V Ceramic Disc -A
1	C12	200PMD2	62-3011	"OBS" 200 pF Capacitor 20% 50V Ceramic Disc -A
9	C13, C14, C62, C63, C66, C67, C80, C81, C85	.22LLM50E2	60-1000	"OBS" 0.22 uF Capacitor 20% 50V Electrolytic, LL-A
5	C15, C25, C26, C29, C31	240PMD2	62-3005	"OBS" 240 pF Capacitor 20% 50V Ceramic Disc -A
6	C16, C37, C41, C59, C61, C74	1NPSE2	60-1004	"OBS" 1.0 uF Capacitor -20%,+80% 16V Elect., N.P.-A
2	C17, C86	.022KF2	56-4000	0.022 uF Capacitor 10% 100V Polyester Film -A
4	C18, C21, C47, C56	.010	56-2022	0.010 uF Capacitor 10% 100V Polyester Film
9	C20, C69, C78, C96, C97, C102, C135, C138, C139	.047 AM	62-0067	0.047 uF Capacitor 20% 50V Axial Monolithic
2	C23, C35	.0033	56-2014	0.0033 uF Capacitor 10% 100V Polyester Film
1	C24	47SE2	60-1009	47.0 uF Capacitor -20%,+80% 16V Electrolytic -A
2	C30, C127	.0027	56-2013	0.0027 uF Capacitor 10% 100V Polyester Film
1	C32	1LLM50E2	60-1003	"OBS" 1.0 uF Capacitor 20% 50V Elect., LL-A
4	C33, C65, C106, C114	100S25E2	60-1015	"OBS" 100.0 uF Capacitor -20%,+80% 25V Electrolytic-S -A
1	C34	.0056	56-2017	0.0056 uF Capacitor 10% 100V Polyester Film
3	C38, C42, C89	.0082	56-2019	0.0082 uF Capacitor 10% 100V Polyester Film
3	C39, C43, C101	470PMD2	62-3002	"OBS" 470 pF Capacitor 20% 50V Ceramic Disc -A
2	C40, C68	.033KF2	56-4002	0.033 uF Capacitor 10% 100V Polyester Film -A
11	C44, C105, C110, C111, C112, C113, C115, C116, C117, C118, C119	100S50E2	60-1013	100.0 uF Capacitor -20%,+80% 50V Electrolytic-A
1	C45	.027KF2	56-4001	0.027 uF Capacitor 10% 100V Polyester Film -A
6	C46, C99, C124, C140, C141, C142	10NPSE2	60-1007	"OBS" 10.0 uF Capacitor -20%,+80% 16V Elect., NP -A
2	C50, C57	.33LLM50E2	60-1012	"OBS" 0.33 uF Capacitor 20% 50V Electrolytic, LL-A
6	C52, C53, C58, C60, C64, C94	120PMD2	62-3001	"OBS" 120 pF Capacitor 20% 50V Ceramic Disc -A
11	C70, C71, C83, C87, C90, C91, C92, C93, C122, C123, C136	1S50E2	60-1002	"OBS" 1.0 uF Capacitor -20%,+80% 50V Electrolytic-A
3	C75, C82, C132	50PJD2	62-3004	"OBS" 50 pF Capacitor 5% 50V Ceramic Disc -A

DOD Software

Page

REVISION HISTORY FOR 05-6190

Revised: September 22, 1994

056190A1.001

Revision: A1

Bill Of Materials

September 22, 1994

9:35:20

Quan	Reference	Part	SYMAN	Description
1	C76	1.5 T		
1	C84	.0018	56-2011	0.0018 uF Capacitor 10% 100V Polyester Film
1	C88	.10	56-2035	0.10 uF Capacitor 10% 100V Polyester Film
1	C98	.0022	56-2012	0.0022 uF Capacitor 10% 100V Polyester Film
2	C100,C109	100PMD2	62-3007	"OBS" 100 pF Capacitor 20% 50V Ceramic Disc -A
2	C104,C108	10 T		
1	C107	15PJD2	62-3010	"OBS" 15 pF Capacitor 5% 50V Ceramic Disc -A
4	C120,C121,C125,C133	10U 400V	60-0310	10.0 uF Capacitor -20%,+80% 400V Electrolytic
4	C126,C128,C129,C143	.0082 250V	56-2219	0.0082 uF Capacitor 10% 250V Polyester Film
2	C130,C131	33 LL	60-0059-01	33.0 uF Capacitor 20% 16V Elect., LL
1	C134	.33 T	62-0160	0.33 uF Capacitor 10% 35V Tantalum
23	D1,D2,D3,D4,D5,D6,D7,D8, D9,D11,D12,D15,D16,D17, D18,D19,D20,D21,D22,D26, D27,D36,D37	1N4148	70-0002	1N4148 Silicon Switching Diode, 75 Volts PIV
15	D10,D13,D14,D23,D24,D25, D28,D29,D30,D31,D32,D33, D34,D35,D38	1N4001	70-0001	1N4001 Silicon Rectifier, 1 Amp, 50 Volts PIV
1	H1	HDR7X2	32-1083	14 Pin Hdr, 7x2, 0.1" spacing, 0.025" pins, .375
1	H2	HDR5 LK	32-1071	5 Pin Header, 0.1" spacing, 0.025" sq pins Lockin
1	H3	HDR10X2	32-1055	20 Pin Hdr, 10X2, 0.1" spacing, 0.025 pins
1	H5	HDR5+ 156	32-1043	6 Pin Header, 0.156 spacing, Right Angle
1	H6	HDR3+ 156	32-1045	3 Pin Header, Right Angle, 0.156 spacing
1	HS1	HS_L BASE	70-4205	Heatsink,
1	HS2	HS_1 TOP	70-4204	Heatsink, 3 Regulator, Top
1	I1	INS_3TO220	70-4209	Insulator, 3 Regulator Heatsink
3	J1,J2,J3	DIN 5	32-0092	5 Pin DIN Jack
3	J4,J5,J7	J250HSFN	32-0119	1/4 HPC Mount Jack Full Nose Thread Slimline
2	J6,J8	J250HSHN	32-0118	1/4 HPC Mount Jack 1/2 Nose Thread Slimline
1	K1	RELAY DPDT	72-5143	DPDT Relay Switch
8	L1,L2,L3,L6,L7,L8,L9,L10	FBEAD	26-0221	Ferrite Bead - 1 Hole
1	P1	TP10K H	42-0211	10 K Trim Pot, Horizontal Mount, 3/4 turn
1	P2	P100K W X2	40-2011	100 K "W" Rot Pot x2, Rack Leads
1	P3	TP50K H	42-0222	50 K Trim Pot, Horizontal Mount, 3/4 turn
1	P4	P100K W RK	40-2012	100 K "W" Rot Pot, Rack Style Leads
3	PA1,HA,HB	PA1	-----	1 Pin Pad, Not a part
1	PA5	PA5	-----	5 Pin Pad, Not a part
1	PA6	PA3	-----	3 Pin Pad, Not a part
1	PCB1	80-6190-A		
6	Q1,Q5,Q6,Q7,Q13,Q22	2N4124	70-1009	2N4124 NPN Gen. Purp. Amplifier/Switching Xstr
8	Q2,Q3,Q4,Q9,Q12,Q19,Q20, Q28	2N5088	70-1007	2N5088 NPN Low Level Amplifier Transistor T&R
4	Q8,Q18,Q21,Q27	2N4125	70-1008	2N4125 PNP Gen. Purp. Amplifier/Switching Xstr
10	Q10,Q11,Q14,Q15,Q16,Q17, Q23,Q24,Q25,Q26	J112	70-1012	J112A JFET National
76	R1,R11,R12,R13,R27,R42, R45,R46,R47,R78,R79,R80, R99,R105,R107,R114,R116, R117,R118,R119,R120,R127, R128,R129,R130,R140,R141, R142,R144,R147,R156,R157, R158,R163,R169,R170,R171,	10K	50-0020	10 KOhm Resistor 5% 1/4 Watt Carbon Film

DOD Software

REVISION HISTORY FOR 05-6190

056190A1.001

Bill Of Materials

Quan Reference

September 22, 1994

Part

Revised: September 22, 1994

Revision: A1

9:35:20

SYMAN

Description

Page

R172,R174,R175,R176,R181,
R183,R186,R187,R190,R191,

	R192,R193,R194,R195,R196, R197,R199,R213,R216,R217, R226,R227,R229,R230,R231, R233,R234,R239,R251,R252, R253,R256,R264,R266,R268, R270,R272,R274,R277										
4	R2,R50,R179,R184	470	50-0006	470	Ohm Resistor	5%	1/4 Watt	Carbon Film			
3	R3,R104,R198	27K	50-0027	27	KOhm Resistor	5%	1/4 Watt	Carbon Film			
5	R4,R112,R201,R228,R258	4.7K	50-0015	4.7	KOhm Resistor	5%	1/4 Watt	Carbon Film			
1	R5	18K	50-0022	18	KOhm Resistor	5%	1/4 Watt	Carbon Film			
13	R6,R25,R33,R63,R110,R111, R154,R160,R161,R165,R265, R267,R269	2K	50-0013	2	KOhm Resistor	5%	1/4 Watt	Carbon Film			
20	R7,R35,R52,R55,R56,R60, R62,R65,R67,R72,R73,R74, R81,R220,R221,R237,R238, R244,R271,R273	1K	50-0012	1	KOhm Resistor	5%	1/4 Watt	Carbon Film			
12	R8,R32,R48,R49,R71,R75, R113,R173,R177,R178,R250, R279	470K	50-0042	470	KOhm Resistor	5%	1/4 Watt	Carbon Film			
1	R9	330K	50-0041	330	KOhm Resistor	5%	1/4 Watt	Carbon Film			
2	R10,R138	33K	50-0028	33	KOhm Resistor	5%	1/4 Watt	Carbon Film			
12	R14,R15,R16,R18,R19,R20, R21,R22,R23,R26,R208, R210	200	50-0004	200	Ohm Resistor	5%	1/4 Watt	Carbon Film			
2	R17,R51	10	50-0001	10	Ohm Resistor	5%	1/4 Watt	Carbon Film			
10	R24,R132,R205,R206,R207, R211,R212,R246,R262,R263	1M	50-0045	1	MOhm Resistor	5%	1/4 Watt	Carbon Film			
5	R28,R29,R54,R145,R209	100	50-0003	100	Ohm Resistor	5%	1/4 Watt	Carbon Film			
7	R30,R44,R91,R168,R203, R248,R259	3.3K	50-0014	3.3	KOhm Resistor	5%	1/4 Watt	Carbon Film			
6	R31,R76,R97,R162,R249, R280	330	50-0005	330	Ohm Resistor	5%	1/4 Watt	Carbon Film			
19	R34,R121,R122,R123,R124, R125,R126,R146,R148,R149, R150,R200,R202,R204,R224, R225,R257,R260,R261	20K	50-0023	20	KOhm Resistor	5%	1/4 Watt	Carbon Film			
7	R36,R85,R86,R89,R96,R115, R137	15K	50-0019	15	KOhm Resistor	5%	1/4 Watt	Carbon Film			
5	R37,R153,R164,R240,R243	220K	50-0040	220	KOhm Resistor	5%	1/4 Watt	Carbon Film			
11	R38,R131,R135,R152,R159, R167,R180,R235,R236,R241, R275	100K	50-0036	100	KOhm Resistor	5%	1/4 Watt	Carbon Film			
2	R39,R151	150K	50-0038	150	KOhm Resistor	5%	1/4 Watt	Carbon Film			
15	R40,R41,R61,R64,R68,R69, R70,R94,R106,R133,R143, R155,R166,R185,R188	47K	50-0030	47	KOhm Resistor	5%	1/4 Watt	Carbon Film			
1	R57	11.0K 1%	52-0105	11.0	KOhm Resistor	1%	1/4 Watt	Metal Film			
1	R58	4.02K 1%	52-0121	4.02	KOhm Resistor	1%	1/4 Watt	Metal Film			
6	R59,R66,R77,R83,R88,R98	5.76K 1%	52-0116	5.76	KOhm Resistor	1%	1/4 Watt	Metal Film			

DOD Software

REVISION HISTORY FOR 05-6190

056190A1.001

Bill Of Materials

Quan Reference

September 22, 1994

Part

Revised: September 22, 1994

Revision: A1

9:35:20

SYMAN

Description

Page

3	R82,R93,R134	22K	50-0025	22	KOhm Resistor	5%	1/4 Watt	Carbon Film			
3	R84,R87,R92	6.8K	50-0016	6.8	KOhm Resistor	5%	1/4 Watt	Carbon Film			
1	R90	51	50-0002	51	Ohm Resistor	5%	1/4 Watt	Carbon Film			
2	R95,R139	62K	50-0032	62	KOhm Resistor	5%	1/4 Watt	Carbon Film			
4	R100,R101,R102,R103	22	50-0158	22	Ohm Resistor	5%	1/4 Watt	Carbon Film			
4	R108,R109,R215,R276	7.5K	50-0017	7.5	KOhm Resistor	5%	1/4 Watt	Carbon Film			
2	R136,R245	120K	50-0037	120	KOhm Resistor	5%	1/4 Watt	Carbon Film			

056190a1.pls

2	R182,R189	24K	50-0026	24	KOhm Resistor	5%	1/4 Watt Carbon Film
2	R214,R254	0	50-0050	0	Ohm Resistor	5%	1/4 Watt Carbon Film
1	R218	12K	50-0021	12	KOhm Resistor	5%	1/4 Watt Carbon Film
2	R222,R223	3.9M	50-0048	3.9	MOhm Resistor	5%	1/4 Watt Carbon Film
1	R232	30K	50-0236	30	KOhm Resistor	5%	1/4 Watt Carbon Film
1	R242	680	50-0007	680	Ohm Resistor	5%	1/4 Watt Carbon Film
1	R247	39K	50-0029	39	KOhm Resistor	5%	1/4 Watt Carbon Film
1	R278	75K	50-0033	75	KOhm Resistor	5%	1/4 Watt Carbon Film
1	RN1	10KRX9	54-0355	10	Pin SIP BX-103	10K	
1	S8	PLCC68S	70-3164	68	PLCC Socket		
2	S12,S14	DIP32S	70-3017	32	Pin Dip Socket		
1	S13	PLCC84S	70-3163	84	PLCC Socket		
6	S17,S19,S21,S23,S25,S27	DIP18S	70-3160	18	Pin Dip Socket		
1	S20	PLCC44S	70-3024	44	PLCC Socket		
1	S24	DIP28S	70-3161	28	Pin Dip Socket		
3	S37,S38,S52	DIP8S	70-3020	8	Pin Dip Socket		
2	S39,S56	DIP20S	70-3018	20	Pin Dip Socket		
2	SR1,SR2	SR6-32_1	28-0058	Screw, 6-32 x 3/8", Pozi-pan, Black			
2	SR3,SR4	SR6-32_2	28-0059	Screw, 6-32 x 1/4", Pozi-pan, Black			
1	SV1	TUBE9S	32-0250	9	Pin Tube Socket		
1	SW1	BINSW	44-0092	16	Bit Grey Code Rotary Switch		
9	TP1,TP2,TP3,TP4,TP5,TP6,TP7,TP8,TP9	TESTP	-----	This is not a part.			
1	TR1	TR260262	26-0262	Inverter-DC to AC Converter for EL DSPLY			
1	U1	7805	70-4014	7805	+5 Volt	1 Amp Voltage Regulator	TO-220
2	U2,U44	74HC244A	72-1107	Octal Buffer-Line Driver W/3-State Outputs			
5	U3,U4,U5,U18,U42	74HC574	72-1112	Octal D-Type Pos. Edge Triggered Flip-Flops			
1	U6	7812	70-4013	7812	+12 Volt	1 Amp Voltage Regulator	TO-220
1	U7	7912	70-4017	7912	-12 Volt	1 Amp Voltage Regulator	TO-220
1	U8	64180ZCP10	72-3154	CPU Z180 Microprocessor			
1	U9	74HC139	72-1100	Dual 2 Line to 4 Line Decoder/Demultiplexer			
1	U10	MC34064P	70-5004	MC34064 Undervoltage Sensing Circuit			
1	U11	74HC04	72-1098	Hex Inverter			
1	U12	27C020-120	72-3076	27C020-120 EPROM Black w/window			
1	U13	S_DISC_EE	72-3172	ASIC, Digitech Custom DSP		84-PLCC	
1	U14	KM681000AL	72-3059	128K X 8 RAM Static			
1	U15	6N138	70-2139	Opto-Isolator			
15	U16,U22,U29,U31,U32,U34,U35,U41,U47,U48,U50,U53,U54,U55,U57	LF353	72-4030	LF353 Wide Bandwidth Dual JFET Input Op-Amp			
6	U17,U19,U21,U23,U25,U27	4464-100A	72-3149-10	64K X 4 Dynamic RAM -100ns			
1	U20	SDAD	72-3176	A/D/A Interface ASIC			
1	U24	PCM54	72-3079	16 BIT DAC			
1	U26	LM311	72-4027	LM311 Analog Voltage Comparator			
1	U28	LM324	72-4028	Low Power Quad Operational Amplifier			

DOD Software

REVISION HISTORY FOR 05-6190

056190A1.001

Bill Of Materials

Quan Reference

September 22, 1994

Part

Revised: September 22, 1994

Revision: A1

9:35:20

SYMAN

Description

Page

2	U30,U51	4053A	72-0086	Triple 2 Pole Analog Mux			
2	U33,U43	4051	72-0081	8 CH Analog Multiplex			
1	U36	78L05	70-4012	78L05	+5 Volt	100 mA Voltage Regulator	TO-92
3	U37,U38,U52	5532	72-4023	5532 Low Noise Dual Op-Amp			
2	U39,U58	LM1973A	72-4043	LM1973 Triple digital controlled analog attenuator			
1	U40	79L05	70-4127	79L05	-5 Volt	100 mA Voltage Regulator	TO-92
1	U45	74HC138	72-1108	3 Line to 8 Line Decoder/Demultiplexer			
2	U46,U56	LM833	72-4246	Low Noise Dual Audio Operational Amp			
1	U49	DBX2155	72-4055	dbx 2155 Voltage Controlled Amplifier			
1	V1	12AX7A2	76-0002	12AX7A Tube			
1	X1	20.00 MHZ	76-0321	20.00 MHZ Crystal			
10	X2,H4,C27,R43,R53,C77,	OMIT	-----	These parts have been omitted			

C79,C137,R219,R255

056190a1.pls