

ESQUEMA ELÉTRICO CE 30 CHORUS (OLIVER)

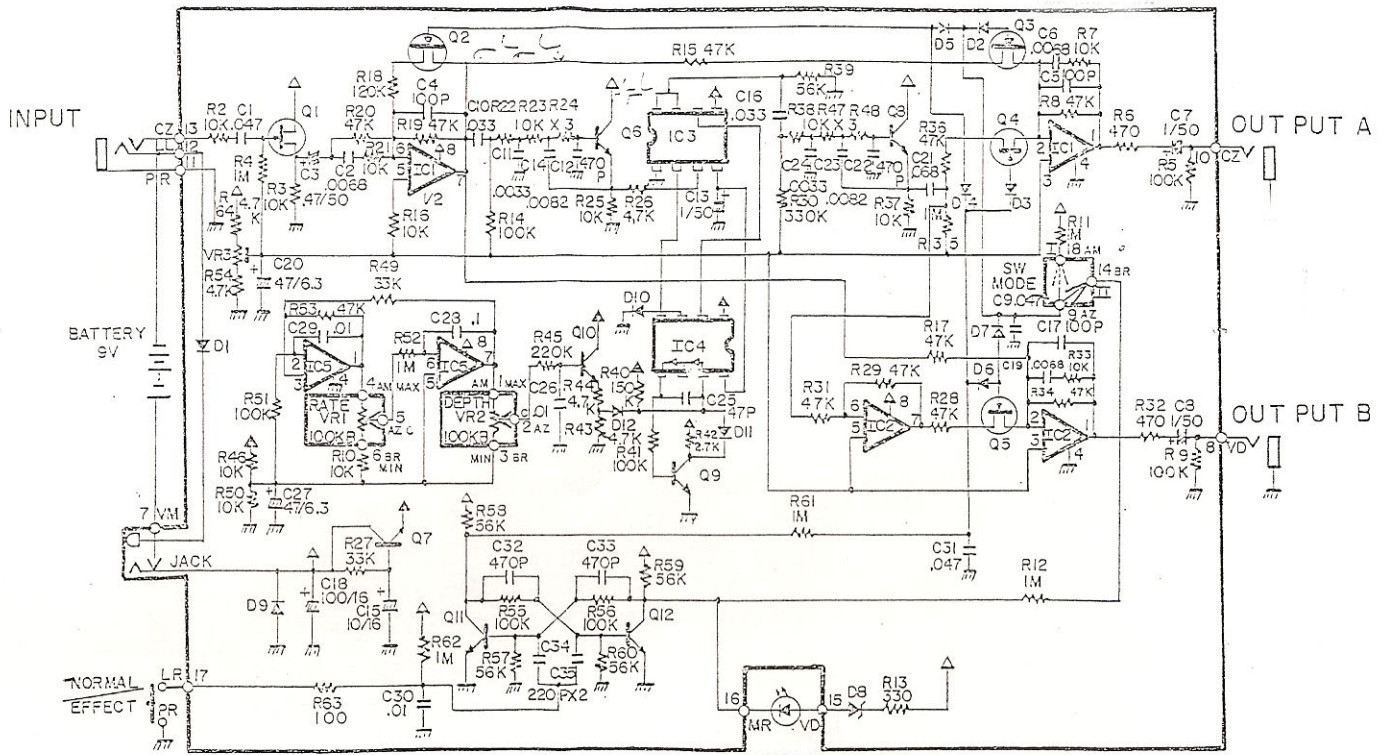

CHECK

- | | | |
|---------------------------|---------------------|----------------------|
| IC1,2 : RC 4558D | Q1-5 : 2SK 30A-Y | D1-7,10-12 : 1S 2473 |
| IC3 : MN3207 (1024) | Q6,8 : 2SC 732TM-GR | D8 : RD 5.6EB-3 |
| IC4 : MN3102 (SBD DRIVER) | Q7,9-12 : 2SC 945P | D9 : 1N 4004A |
| IC5 : 1R 9022 | | |