

Jinx

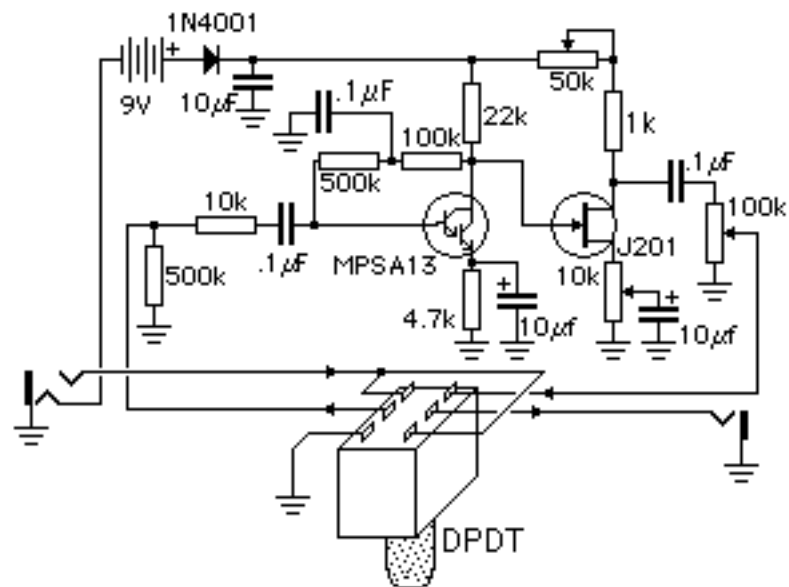

v1.1
2/03

The evolution from a Fuzz Face style highly variable fuzz to a more easily reproduced highly variable fuzz. The 10k and 50k pots on the source and drain of the JFET are highly interactive, allowing everything from "soft attack" fuzz effects to octave up to regular fuzz tones.