

Q&D VCF

v 1.1
3/03

Served with and without oscillations!

These two designs are quasi synth VCFs, useful to get a decent fake lowpass response with a minimum of parts. Trim the input levels so that the output is unity gain with the Resonance set low and the cutoff frequency set all the way up. Two versions here, one will oscillate with the Resonance maxxed out, one won't. Get your guitar synth going with one of these filters!

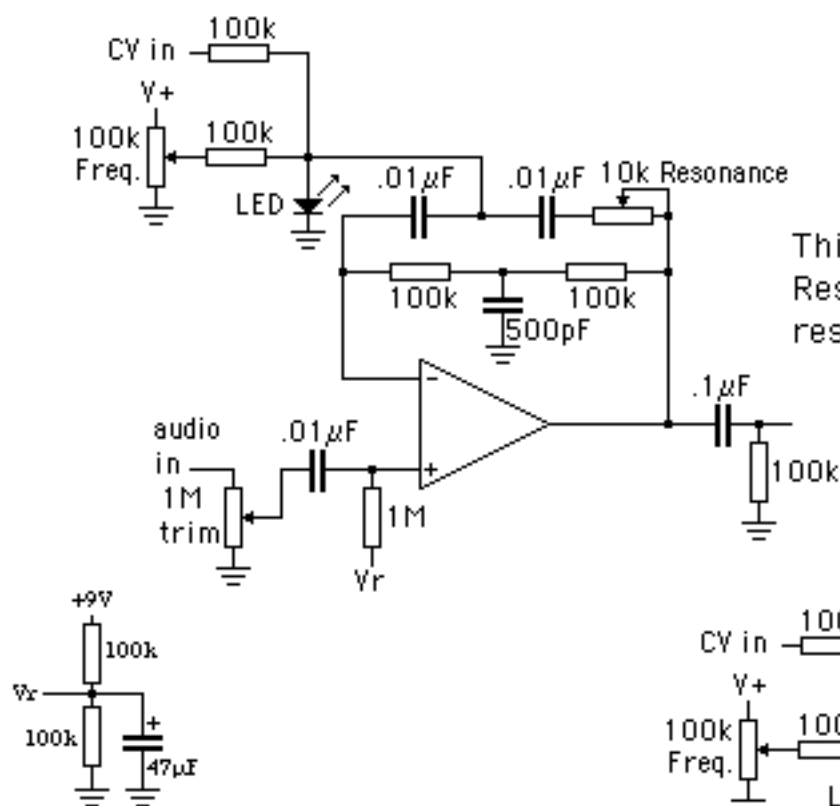

This version will oscillate when Resonance control is set to minimum resistance.

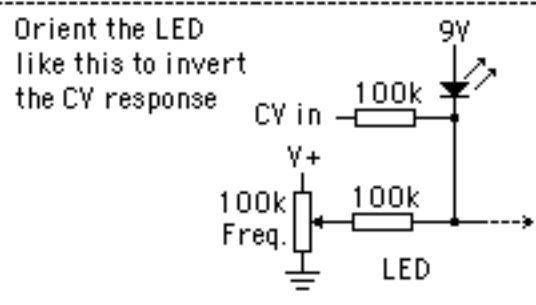

This version has a nicer resonant peak but will not oscillate even with Resonance cranked.

