

Tripple Fuzz

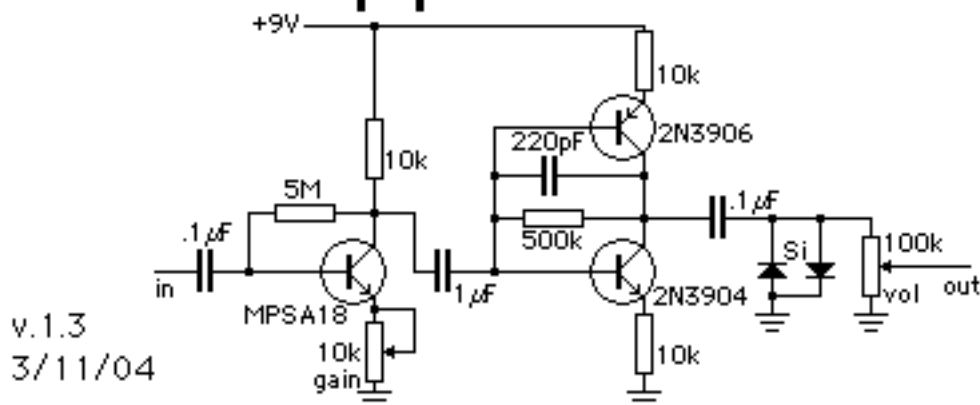

This is a fuzz using a "nonselective frequency tripler", originally designed by R. Lockhart Jr. At low gains the sound can be very sweet. As the gain rises, you get a odd splatty fuzz going on. And at max gain, it's completely nasty. A nice, easy build.

Thanks to Ken Stone for the lead