

FENDER VIBRATONE

OWNER'S
MANUAL

General Operating and Maintenance Instructions



FENDER VIBRATONE

Give yourself a complete new experience in sound with the Fender Vibratone. The Vibratone incorporates the famed Leslie® Vibrato Speaker System which, when used in conjunction with a standard amplifier, gives all instruments, including guitar and organ, a tonal versatility from cathedral elegance to funky blues depending on your control settings.

Two distinctly different tremolo sounds are available as the unit has two speeds controlled by a foot switch. A second switch enables the player to change from the regular guitar amplifier's speaker to the vibratone. A unique crossover system allows both low and very high frequencies to always emanate from the regular amp speaker(s) when the signal is switched to Vibratone. This maintains a constant clean mid-range tremolo tone in the Vibratone Unit.



Index

| | PAGE |
|---------------------------------|------|
| CONNECTOR CABINET | 7 |
| DESCRIPTION | 1 |
| LUBRICATION | 3 |
| TREMOLO ASSEMBLY | 9 |
| MOTOR ADJUSTMENT | 5 |
| MOTOR CLEANING | 5 |
| MOTOR OILING | 4 |
| MOTOR REMOVAL | 4 |
| ORDERING PARTS | 7 |
| ROTOR OILING | 4 |
| SET-UP INSTRUCTIONS | 2 |
| SPECIFICATIONS | 3 |
| TREMOLO UNIT INSTALLATION | 7 |
| TREMOLO UNIT REMOVAL | 4 |
| TWO-SPEED MOTOR ASSEMBLY | 8 |

S
M
ir
1
2
3
4
5
6
7
N
n

DNE

SET-UP INSTRUCTIONS

Make certain main amplifier is turned off before making Vibratone installation.

1. Plug the 5-contact socket of main connector cord into Vibratone as shown at "U" position.
2. Place remote foot switch "V" at some convenient location for player.
3. Plug AC line cord from Vibratone into wall outlet and turn on switch "T".
IMPORTANT: After transporting Vibratone, plug line cord into wall outlet, turn on power switch at Vibratone cabinet, push tremolo foot switch and wait 5 seconds, then push again.
4. Make certain that crossover assembly "E" is plugged into the 6-contact socket of main connector cord.
5. Remove phone plug "A" from amplifier speaker jack "D".
6. Plug phone plug "C" into input "D".
7. Plug amplifier speaker cord jack "A" into phone jack receptacle "B".

NOTE: Do not use amplifier external speaker jack as Vibratone will not function.

ler Vibratone.
 system which,
 struments, in-
 stance to funky

as two speeds
 change from
 crossover sys-
 temate from the
 this maintains

PAGE

..... 7

..... 1

..... 3

..... 9

..... 5

..... 5

..... 4

..... 4

..... 7

..... 4

..... 2

..... 3

..... 7

..... 4

..... 8

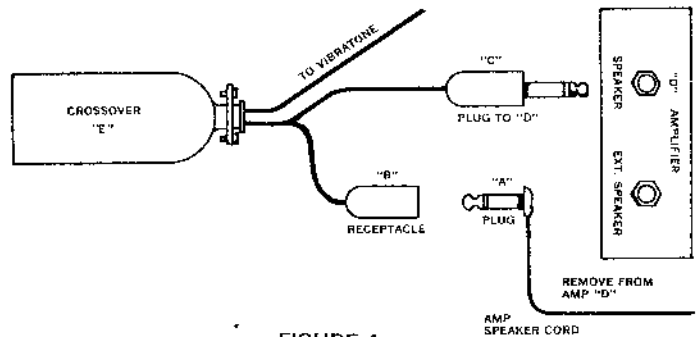

FIGURE 1

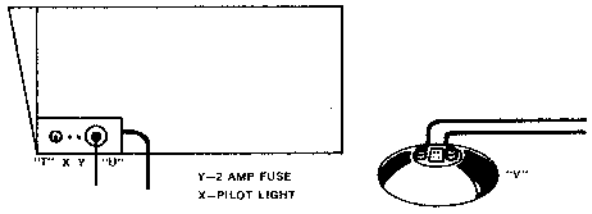

FIGURE 2

VIBRATONE SPECIFICATIONS

Cabinet: Leatherette covered case.

Dimensions: 29" high; 21 $\frac{1}{8}$ " wide; 14 $\frac{3}{4}$ " deep.

Loudspeaker: High quality, heavy-duty, 10-inch permanent magnet, 4 ohm impedance. It has a handling capacity of up to 100 Watts, when properly connected.

Amplification: The Vibratone is driven by the combo or guitar amplifier.

Controls: A foot switch assembly houses the two control switches. The tremolo switch controls fast and slow movements of the rotor. The Leslie switch selects the output from the combo or guitar amplifier for either its regular speakers or the Leslie.

Weight: 63 pounds net, 70 pounds boxed.

Electrical: Operates on 117 Volts, 60 Hz A. C. current; 60 Watts of power.

Guarantee: One year from date of purchase covering both workmanship and materials. This guarantee does not cover belts or speaker cones which may wear out in less than a year due to severe usage.

VIBRATONE SERVICING

Lubrication Requirements

The motors require little lubrication, and usually only at yearly intervals. The requirement is related to the amount of usage, but other factors can be involved; dust and dirt, for example, can absorb the lubricant, leaving the bearings too dry to operate properly. Generally though, there is a tendency to over-oil.

To determine if oiling is necessary, press a clean, dry screwdriver against the felt pads around the bearing in the rotor assembly and in the large motor. If oil is transferred to the screwdriver, oiling is unnecessary, and even undesirable.

Over-oiling is just as detrimental to the speaker's operation as under-oiling.

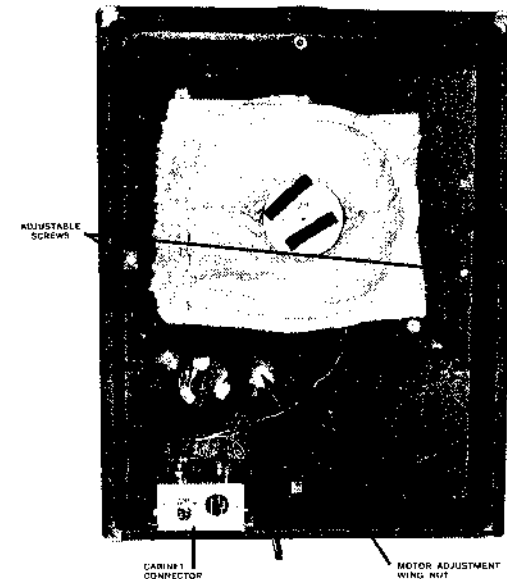

FIGURE 3

Tremolo Unit Removal (See Fig. 3)

CAUTION — Disconnect power before proceeding.

1. With the speaker lying on its front, remove the back and spacer blocks.
2. Unplug the speaker and motor wires from the connector box.
3. Remove connector box.
4. Remove the tremolo unit mounting screws (2) and gently lift out tremolo unit.

Rotor Oiling

The Rotor may be oiled without removing either the rotor assembly or the motor assembly from the mounting board. Simply apply oil to the felt pads around the bearings, avoiding excess which cannot be absorbed by the pad. (A maximum of 10 drops.) (See Fig. 4)

Motor Removal

The motor assembly may be removed simply by removing the two wing nuts (one on either side of the mounting board) and lifting off the motor assembly.

Motor Oiling (See Fig. 10)

1. Remove small motor assembly and support bracket.
2. Remove large pulley (A) using 3/32 hex (allen) wrench.
3. Remove "U" bracket (B).
4. Apply oil to locations shown in Fig. 6, avoiding excess which cannot be absorbed. (A maximum of 10 drops.)
5. The motor may now be assembled by reversing the above procedure.
NOTE: The large pulley should be pushed all the way onto the motor shaft, then lifted about 1/16 inch and tightened in place.
6. The motor assembly should now be adjusted. See "Motor Adjustment".

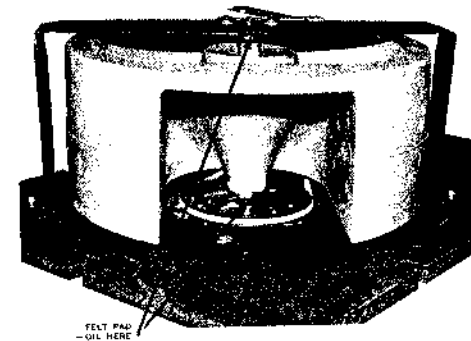

FIGURE 4

MOTOR OILING AND ADJUSTMENT

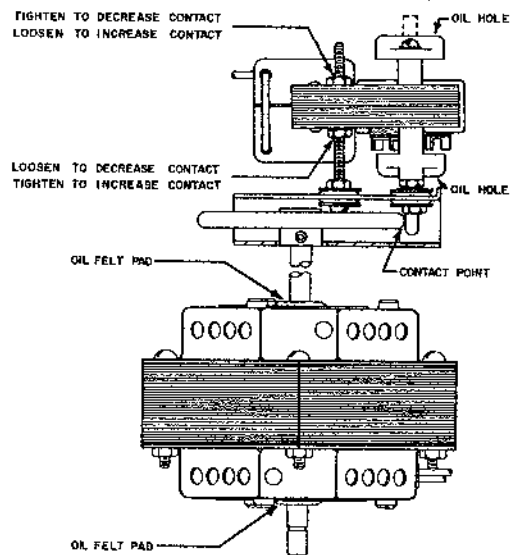

FIGURE 5

Motor Cleaning (See Fig. 7)

1. Remove small motor assembly and motor support bracket.
 2. Remove large pulley (A) using 3/32 hex (allen) wrench.
 3. Remove "U" bracket (B).
 4. Remove small pulley and snap ring (H&I).
- NOTE:** Do not remove motor assembly mounting bracket (G).
5. Mark position of end bells in relation to laminations to assure proper reassembly of large motor.
 6. Remove screws which hold the large motor together and disassemble the motor.
 7. Remove the small motor from its mounting bracket (P).
 8. Remove the two screws in the small motor and disassemble it, noting carefully the relationship between the laminations and end bells. (Reversing the laminations will cause a reverse rotation of the motor.)
 9. Clean all parts in solvent and allow them to dry.
 10. The motors may be assembled by reversing the above procedure. See "Oiling" section.

NOTE: When installing the large pulley (A), push it on the shaft all the way, then pull it back 1/16 inch and tighten in place.

NOTE: It may be necessary to readjust the motor assembly for proper operation. See "Motor Adjustment".

Motor Adjustment

The small motor drives the rotor at slow speed (Chorale) by means of the rubber-tired drive pulley, which actually causes the large motor to turn at a slow contact with the rubber-tired drive pulley whenever the small motor is off. When the small motor is turned on, magnetic attraction moves the armature into operating position, which automatically brings the end of the motor's shaft into contact with the rubber-tired drive pulley. If the end of the small motor's shaft does not properly engage the rubber-tired drive pulley, an adjustment should be made.

1. Raise the mounting board, with rotor and motors installed, to the upright position, as it would be in the speaker cabinet. (See Fig. 3).
2. Adjust the rotor drive belt tension so that the large motor operates the rotor properly, (standing start to full speed in about 5-8 seconds), using the adjusting screws and wing nuts.
3. With the small motor ON, turn the adjusting nuts so that the small motor is completely disengaged with the rubber-tired drive pulley. (See Fig. 5).

4. While holding the rotor so that it cannot move, turn the adjusting nuts so that the motor pulley turns under the belt.

NOTE: Avoid excessive pressure on the rubber tire.

5. When the optimum adjustment has been obtained, secure the motor by tightening the nuts against the laminations.
6. Run-test motor; excessive noise may indicate that one or both of the large motor bearings are mis-aligned. In this case, tap the motor laminations with a hammer to seat the bearings.

Installing Tremolo Unit

FOR PROPER ASSEMBLY, TO AVOID RUINING THE ROTOR DRIVE MECHANISM, FOLLOW THE INSTRUCTIONS BELOW: (See Fig. 6).

1. With cabinet standing upright, as shown, tilt tremolo board and position bottom against support as shown in Fig. 6.
2. Tilt tremolo up until it is entirely upright and against support.
3. Lay cabinet on front and replace other parts and connect wires.



FIGURE 6

ORDERING PARTS

Sockets, connectors and standard value components (resistors, condensers) are available through local electronic supply houses. Most of the "hardware" items (bolts, nuts, screws) are also locally available. Non-standard items or components with close tolerances should be obtained from Fender Musical Instruments.

To avoid errors, orders should include part numbers, as given (see Figs. 7, 8, 9 & 11). Including the serial number of the Vibratone for which the parts will be used is also helpful.

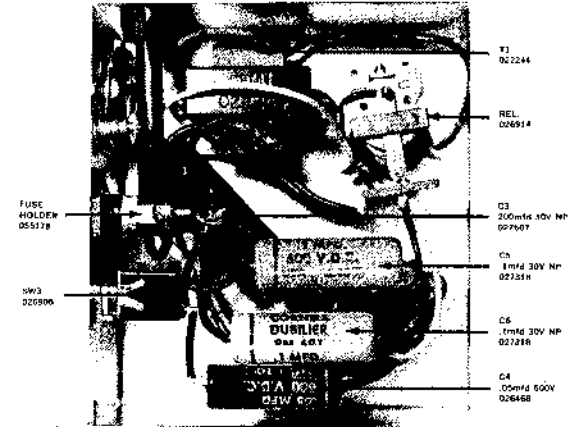
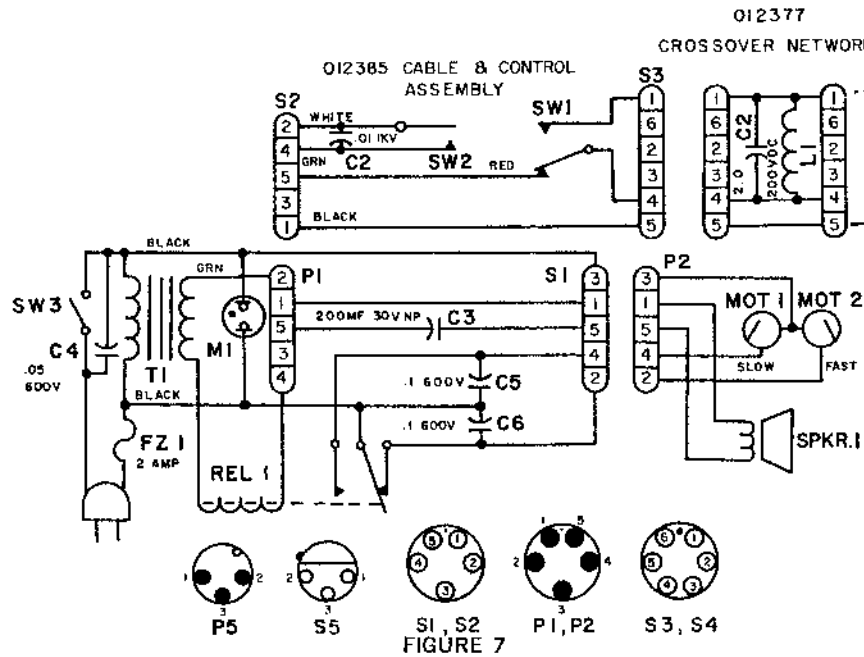

FIGURE 9

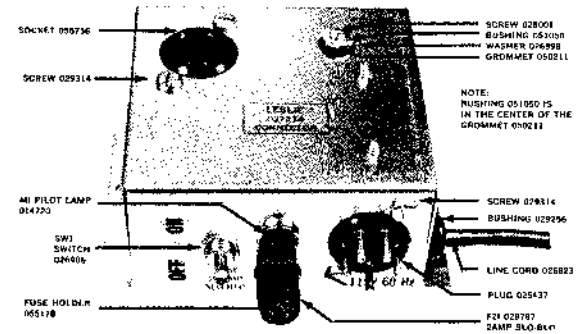

FIGURE 8

TL
077244

REL
026914

C3
200mfd 30V NP
027607

C5
.1mfd 30V NP
077318

C6
.1mfd 30V NP
027316

C4
100mfd 600V
026466

SCREW 029001
BUSHING 051109
WASHER 020998
DROMMET 05921E

IFNG 051009 IS
1/2 CENTER OF THE
4MET 050211

SCREW 029314
BUSHING 079256

LINE CORD 026803

PLUG 025417

F24 028787
2AMP SLO BEL

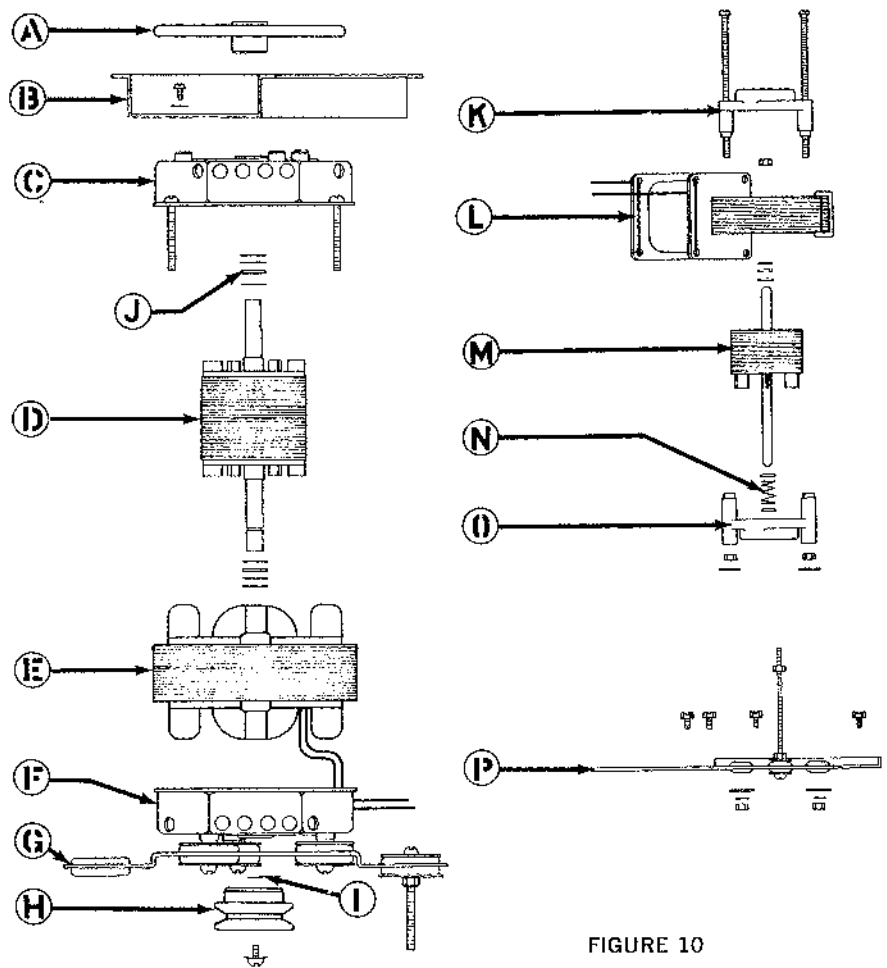

Two-Speed Motor Assembly

- A - Large Rim Drive Pulley
- B - "U" Bracket
- C - Large Motor End Bell
- D - Large Motor Armature
- E - Large Motor Laminations
- F - Large Motor End Bell (note wire hole)
- G - Motor Assembly Mounting Bracket
- H - Small Pulley
- I - Pulley Snap Ring
- J - Large Motor Armature Washers (both ends)
- K - Small Motor End Bell
- L - Small Motor Laminations
- M - Small Motor Armature
- N - Small Motor Spring & Washers
- O - Small Motor End Bell
- P - Small Motor Mounting Bracket

FIGURE 10

Tremolo Assembly

- 010165 Acoustic Pad
- 010603 Rotor Support Assembly
- 010611 Rotor Support
- 010629 Bearing Assembly
- 010637 Bearing Plate
- 010645 Bearing, Oilite
- 010645 Bearing, Oilite
- 010660 Bearing Retainer
- 010678 Bearing Sleeve
- 010728 Motor Bracket
- 010744 Locking Lever
- 011700 Belt
- 013235 Grommet
- 013243 Bearing, Oilite
- 013250 Felt, Oil
- 013268 Bearing Retainer
- 014027 Drive Wheel with Tire
- 014050 Bushing
- 014068 Bracket
- 014076 Motor Small, MOT 1
- 014084 Grommet
- 014159 Tire for Drive Wheel 014027
- 014233 Bushing, Neoprene
- 017012 Motor "U" Bracket
- 017301 Rotor Support
- 017319 Bearing Support
- 026328 Lock Washer
- 026500 Screw 10-27x7/4"
- 026716 Felt Washer
- 026740 Screw 8-32x3/8"
- 026849 Bracket, "Z"
- 026880 Motor Assembly, 2 speed
- 026955 Speaker, 10 inch
- 027714 Connector Chassis
- 027722 Wood Spacer for Back
- 027995 Staple
- 028043 Cloth Shim
- 048124 Grommet
- 050625 Wing Nut
- 050641 Grommet
- 050666 "C" Ring
- 051060 Bushing
- 051607 Motor Pulley
- 051771 Rotor Pulley
- 055079 Bushing
- 060269 Motor Large, MOT 2
- 060590 Drive Link
- 060608 Rotor, Foam
- 060723 Bushing, neoprene
- 060731 Pin
- 061176 Shaft

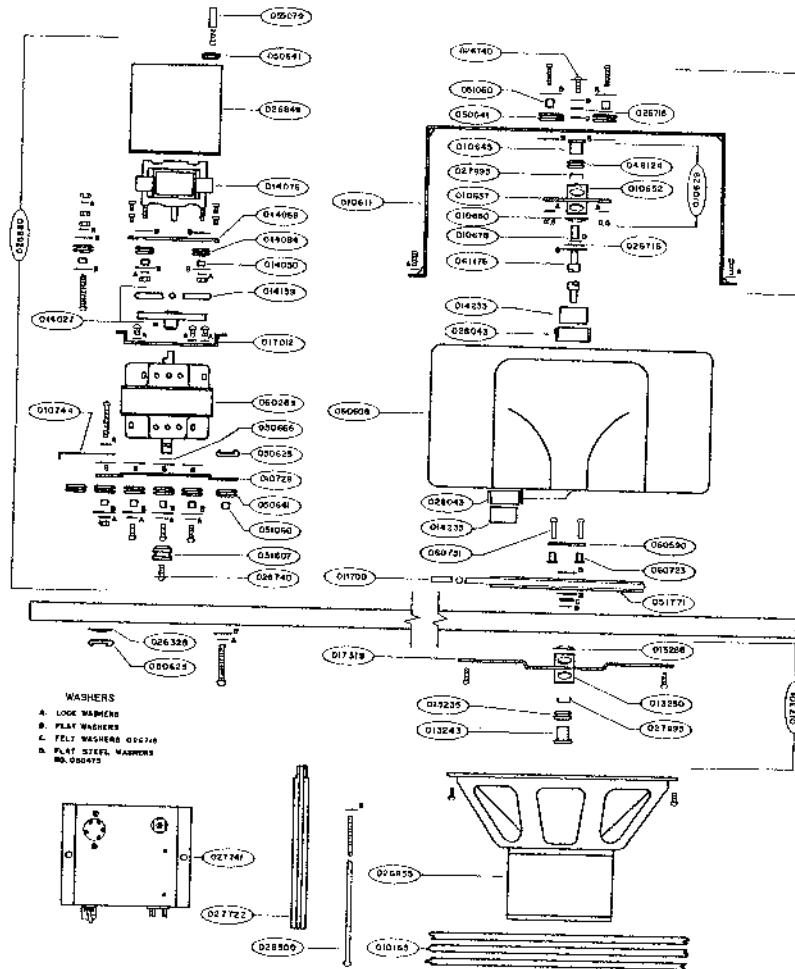

LESLIE TREMOLO ASSEMBLY

FIGURE 11

WARRANTY

Fender Musical Instruments warrants the parts in any Fender Vibratone to be free from defects in workmanship and material arising from normal usage. Its obligation under this warranty is limited to replacing any such parts of the vibratone which, after regular installation and under normal usage and service, shall be returned within ninety (90) days from the date of original purchase of the amplifier to the authorized dealer from whom the purchase was made and which shall be found to have been thus defective in accordance with the policies established by Fender Musical Instruments. All transistors are guaranteed for one year.

The obligation of Fender Musical Instruments is limited to making replacement parts available to the purchaser, and does not include either the making or furnishing of any labor in connection with the installation of such replacement parts nor does it include responsibility for any transportation expense. Fender Musical Instruments assumes no liability and shall not be liable in any respect for failure to perform or delay in performing its obligations with respect to the above warranty if such failure or delay results, directly or indirectly, from any preference, priority or allocation order issued by the Government, or because of any other act of the Government, or by war, conditions of war, inadequate transportation facilities, conditions of weather, acts of God, strikes, lockouts, Governmental controls, or Fender's reasonable requirements for manufacturing purposes, or any cause beyond its control or occurring without its fault, whether the same kind or not.

CONDITIONS and EXCLUSIONS This warranty is expressly in lieu of all other agreements and warranties, expressed or implied, and Fender Musical Instruments does not authorize any person to assume for it the obligations contained in this warranty and neither assumes nor authorizes any representative or other person to assume for it any other liability in connection with such solid-state amplifier or parts thereof.

The warranty herein extends only to the original consumer purchaser and is not assignable or transferable and shall not apply to any vibratone or parts thereof which have been repaired or replaced by anyone else than an authorized Fender dealer's service contractor, or which have been subject to alteration, misuse, negligence or accident, or to the parts of any vibratone which have had the serial number or name altered, defaced or removed. This guarantee specifically excludes loud speakers with torn or ruptured paper diaphragms.

MUSICAL INSTRUMENTS REPAIRS
Fender Musical Instruments—A Division of Columbia Broadcasting System Inc.
LESSONS

Purchased AMC 4-24-71
llh

FENDER VIB

