

Service Manual

800RB

Table of Contents

Operating Instructions	3
Turn On / Calibration Procedure	6
Schematics	11
Engineering Change Orders (ECOs)	24
Bill of Materials	34

The Basics

Your new GK 800RB Bass Amplifier represents the latest advances that technology has to offer. Contained in a small lightweight package are a set of unbeatable voicing filters, a four-band equalizer, a tunable electronic crossover and a bi-amp power amplifier. When used properly, these features will give you the most exciting bass sound available today. A careful examination of this manual will help you understand how to take full advantage of its capabilities.

Block Diagram

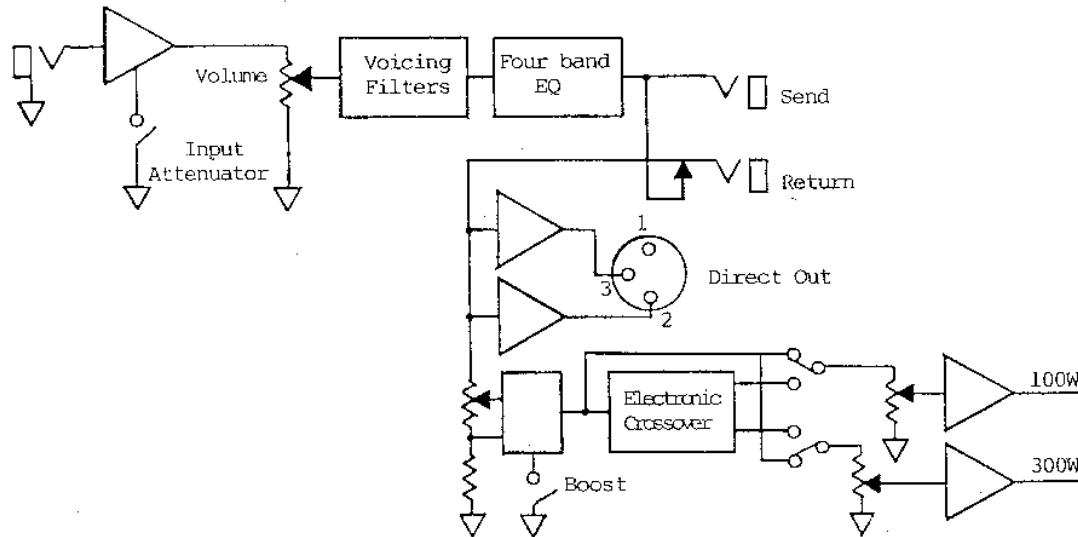

Input Section

This section contains the 1/4" input jack and the input attenuator. With the attenuator out, the maximum input level is 1V rms (3V P-P). For larger input signals, the input attenuator should be set. This reduces the gain of the input stage by 10dB, increasing the input head room to 3V rms (10V P-P).

Effects Loop

Located on the rear panel, it is provided for the insertion of outboard effects. It is post EQ but pre Boost and Master. Using standard guitar cords, connect the effects input to the send and the effects output to the return. The Boost and Master controls will not effect any signal put into the return jack. The level is 1.5V rms (4.5V P-P) into 100K ohm.

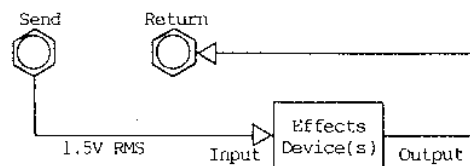

Direct Out

This is an electronically balanced output that will put 500 mv rms into a 600 ohm load. It comes after the effects loop and is located on the rear panel.

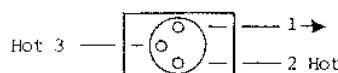

Speakers

Located on the rear panel are two sets of speaker jacks. The upper set is for the 100W power amp and in the bi-amp mode is used for the high end. They deliver 100W rms into 8 ohms. Lower impedances should not be used. Higher impedances such as 16 ohms or above are okay. The lower set of jacks are for the 300W power amp, and are used for the low end in the bi-amp mode. They deliver 300W into 4 ohms, lower impedances should not be used. Higher impedances such as 8 ohms or above are okay.

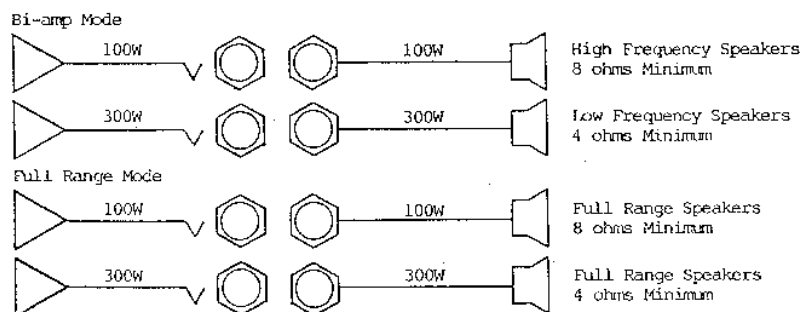

CAUTION: Under no circumstances should the 100W and 300W outputs be connected together or to the same speaker!

Power Switch

The Power Switch and associated LED indicator are located in the lower right hand corner of the front panel.

Fuse

Located on the rear panel, never operate this amplifier with any other than the recommended fuse:

- 115V operation - replace with Type 3AG7A
- 230V operation - replace with Type 3AG4A

Power Cord

The Power Cord is detachable and plugs into the rear panel socket. If a replacement is used it should be UL rated for 10A, 125V operation. If using 240V, the cord should be UL rated for 240V, 5A operation.

Maintenance

Your new amplifier is rugged. It was built to give you a lifetime of trouble-free operation. If it is operated in accordance with the instructions above, your only maintenance problems should be cleaning. We recommend a soft damp cloth and mild soap for cleaning the outside surfaces. If you are going to pack your amplifier around alot, we recommend a road case to protect it from scratches and road wear. Road bags are available from Gallien-Krueger.

Setting Up Your Sound

Your amplifier is designed to sound about right with the tone controls set flat (at "5"). We therefore recommend you start with the EQ set flat, the voicing filters out, and the crossover at 500Hz ("5").

Helpful Hints

1. Don't be afraid to experiment with the EQ on your Bass first. Make sure

"Setting Up Your Sound" cont.

that you have as close to the sound you want from your Bass before adjusting the EQ on your amp.

2. Set your playing level first. You may want to push up your volume and boost levels while dropping back the masters. This will give a fatter sound but can add distortion. Some players find this desirable, you will have to be the judge. For the cleanest possible sound, operate the masters near or on "10" (max). The boost control is footswitchable and can act as a preset volume. The LED next to the boost control indicates that boost is on.

3. You may have to experiment with the crossover point and the relative levels of the high and low masters. It is best to adjust them before the EQ. They should be adjusted to give the most desirable sound without distorting the high end speakers. If the crossover confuses you, try switching out of the bi-amp mode and set up your sound in the full range mode first.

4. Once your basic levels are set, work with the voicing filters. The Lo Cut is a bass roll-off and is used to control stage rumble at high volume. Mid Cut puts a notch at about 500Hz, giving a mellow round sound. Hi Boost adds edge and definition.

5. Having set your levels and filters you are ready to fine tune your tone. This is an involved procedure requiring you to use your ears to tell you what is right. We have broken the sound spectrum into four basic bands and provided active controls for each. Adjustment procedures are iterative and require patience. After you have adjusted the EQ, you may want to fine tune the crossover and master controls.

TREBLE: Boost and cut at 4KHz, will add or remove edge and definition.

HIGH MID: Boost and cut at 1Khz. There is a lot of sound in this band. It works on the lower harmonics of your instrument and effects the punch of your sound.

LOW MID: Boost and cut at 250Hz. Basically, this band effects the body of your sound.

BASS: Boost and cut at 60Hz. Effects only the bottom end and will be used to account for varying room acoustics.

Specifications

<u>NORMAL GAIN</u>		<u>POWER HI-AMP</u>	
Sensitivity	2mv rms	8 ohm	100W
Max Level	1V rms	16 ohm	60W
Impedance	1M ohm		
<u>-10 GAIN</u>		<u>POWER LOW-AMP</u>	
Sensitivity	6mv rms	8 ohm	200W
Max Level	3V rms	4 ohm	300W
Impedance	1M ohm		
<u>EFFECTS SEND</u>		<u>BOOST PRESET</u>	
Level(Boost off)	1.5v rms	Switch to Ground, 15dB Max	
Impedance	100K ohm min	<u>SHIPPING WEIGHT</u>	
<u>DIRECT</u>		23 pounds	
Level	500mv rms	<u>DIMENSIONS</u>	
Impedance	600 ohm	5 1/4"H x 17 1/4"W x 9 1/2"D	

800RB T/O Procedure

GK Doc. # 420-0045-C

Board #'s: 206-0045-C (preamp), 206-0044-A (power amp),
206-0048-A (power supply). 800RB- all options 8/19/91

Setup

- 1) Variac on 0, power switch off- connect power cord.
- 2) Connect outputs to load box (100W-> load A, 300W-> load B).
- 3) Resistance loads open (switch in center).
- 4) Speaker on (connected to 100W output).
- 5) Load box to scope-B and AC- VM.
- 6) Set scope switch on load box to look at load A (down).
- 7) Set oscillator on 200 Hz sine wave @ 5mVrms (-46dBV).
- 8) DVM on 20mV (dc) range.
- 9) Scope -B on 10V/cm.
- 10) Scope sweep on 1ms/cm, scope trigger on B on RB front panel, set:
- 11) Tones, masters and boost to 10, switches out.
- 12) Volume and bi-amp frequency on 0.

Power Supply and Power Amp Test

NOTE: Unless otherwise specified, output levels are in Vrms and taken from 100W output. Flip scope switch up to load B to see 300W output.

- 1) Power switch to ON. Gradually turn up variac to 50V, while listening to speaker and watching scope and ammeter. Output should go negative, then snap back to 0V. Flip switch to check 300W output, also.
- 2) Check regulated supplies: (+or-) 14.5V, (+ or -) 1V.
- 3) Adjust variac to 120V and turn speaker OFF.
- 4) Set bias: 300W- adjust R38 (on '44 board) for 5mV DC across R48, R49,& R50 (most pos. of the 3) and R54, R55, & R56 (most neg. of the 3).
- 5) Set bias: 100W- adjust R14 for(on '44 board) for 5mV across R25, R26.
- 6) Power LED and boost LED should be lit.
- 7) Connect oscillator to input. (200 Hz @ -46dBV).
- 8) Turn on 4 ohm load for 300W amp and 8 ohm load for 100W amp.
- 9) Adjust volume for slight clipping in 300W amp. 300W output- 36Vrms.
- 10) Reduce volume for slight clipping in 100W amp. 100W output- 28Vrms.
- 11) Engage -10dB switch- output becomes 6.0V. Disengage switch.
- 12) Turn boost to 0. Output becomes 3.1V.
- 13) Turn master to 0. Output becomes 0V.
- 14) Turn loads off.

Tones, Filters, and Bi-Amp Test

- 1) Set bi-amp knob to 0, all others to center (12 o'clock), switches out.
- 2) Set scope-B to 5V/cm and 1ms/cm.
- 3) Set oscillator to 200Hz square wave at -46dBV.
- 4) Look at output, compare to Figure 1.
- 5) One at a time, turn tone control knobs and compare output to figures (resetting each to center position after finishing):
 - A) Treble to 10- Fig.2; treble to 0- Fig.3.
 - B) Hi-mid to 10-Fig.4; hi-mid to 0-Fig.5.
 - C) Lo-mid to 10-Fig.6; lo-mid to 0-Fig.7.
 - D) Bass to 10-Fig.8 bass to 0-Fig.9.
- 6) Engage Low-cut switch, compare to Fig. 10. (Disengage).
- 7) Engage Contour switch, compare to Fig. 11. (Disengage).

- 8) Engage Hi-boost switch, compare to Fig. 12. (Disengage).
- 9) Engage Bi-amp switch. Compare 100W output to Fig. 13.
- 10) Compare 300W output to Fig. 14.
- 11) Set Freq. Knob 10, compare 100W output to Fig. 15.
- 12) Compare 300W output to Fig. 16. Disengage Bi-amp switch.

Noise Test

- 1) Remove oscillator input.
- 2) Turn front panel knobs to 10, switches out.
- 3) Connect speaker to 100W output and listen for noise. It should be smooth and not crackling. Repeat for 300W output.
- 4) Change AC voltmeter range to 1V
- 5) Noise(both amplifier outputs) should measure less than 400mV.
- 6) Engage low-cut, contour, and hi-boost. Noise<400mVrms.
- 7) Volume to 0. Noise< 110mVrms.
- 8) Boost to 0. Noise<15mVrms.
- 9) Engage bi-amp switch. 100W noise< 20mVrms, 300W noise< 5mVrms.

RETURN KNOBS TO ZERO, SWITCHES OUT- READY FOR BURN-IN.

800RB T/O Procedures

Rev.1- 2/1/88

- 1) Inspect wiring on PC boards.
 - 2) Connect power:
 - A) Variac at zero.
 - B) Speaker on B ,scope on B.
 - C) Load off.
 - D) Trimpots halfway.
 - E) Tones and master on 10, filters out, volume off.
 - 3) Gradually adjust variac to 50 Vrms. Listening to speaker and watching scope signal should pop negative then go to zero.
 - 4) Check regulated supplies: (+or-) 14.5 V.
 - 5) Adjust variac to 120V and turn speaker off.
 - 6) Set bias:
 - A) Adjust 38R TP to get 5mV across R48, R49, & R50 (the most pos. of the 3), and R54, R55, &R56 (the most neg. of the 3).
 - B) Adjust R14 to get 5mV across R25 & R26.
 - 7) Connect sine input (200Hz, 20 mVp-p) – 44dB.
 - 8) 8 ohm load for 100W amp, 4 ohm load for 300W amp.
 - 9) Check for full power on high and low amps.
 - A) Slowly turn up volume until amp hits the rails- check output on both amps: 100W= 32 Vrms, 300W= 40Vrms.
 - B) Check master pots when looking at output of both amps.
 - 10) Turn loads off.
 - 11) Connect square wave input (200 Hz, 20 mVp-p) –44dB.
 - A) Boost on zero, volume at 2 o'clock.
 - B) Test attenuation and filters.
 - C) Test tone control.
 - D) Turn on bi- amp- check if crossover works on both high and low amps.
- NOTE: When test filters, tones and crossover compare w/ figures.
- 12) Turn bi-amp off.
 - 13) Check direct out- NOTE: If direct out does not seem right- use DVM should read .6Vrms at full power (AC)
 - 14) Remove input, speaker on, no load.
 - 15) Noise and tap test:
 - A) <300mV- all controls on 10, contour off.
 - B) <500mV- all controls on 10, contour on.
 - C) <700mV- all controls on 10, contour on, crossover on.
 - D) <70mV - volume off, controls on 10, contour on.
 - E) <40mV - volume off, controls on 10, contour off.
 - F) <6mV - volume off, controls on 10, boost off, contour off.

NOTE: <30mV- volume off, controls on zero, bi- amp highmaster on 10. This is to be done while listening to high end of the amplifier.

800RB WAVEFORMS

200 Hz square wave @ -46dBV (5mVrms) input
All knobs to 12:00, switches out
Look at 100W output with scope set on 1ms/div and 5V/div

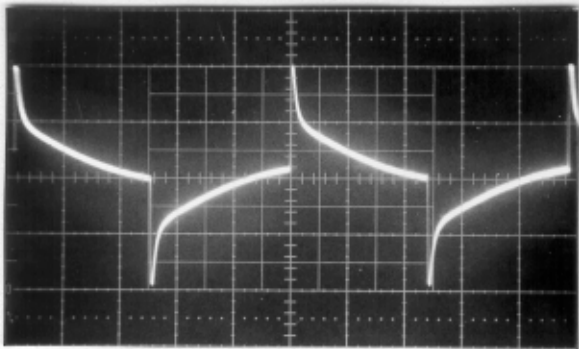

Fig. 1. Tones Center, Filters Off.

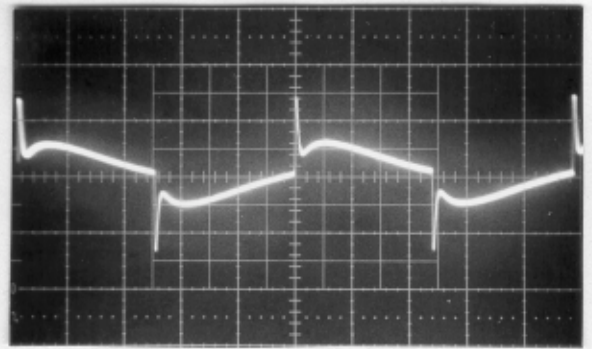

Fig. 5. Hi-Mid to 0.

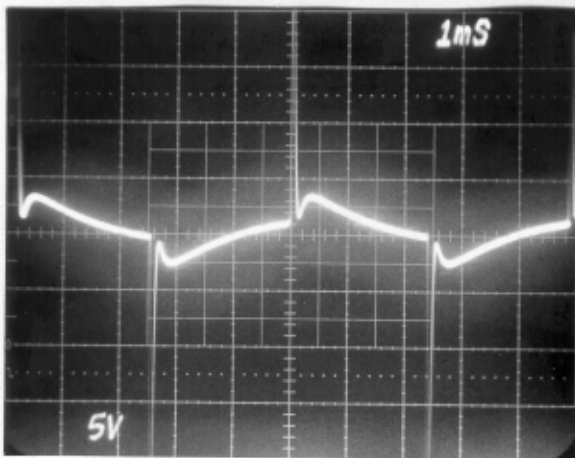

Fig. 2. Treble to 10.

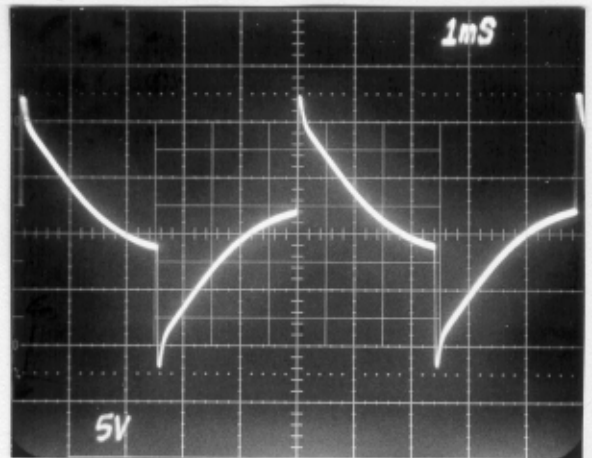

Fig. 6. Lo-Mid to 10.

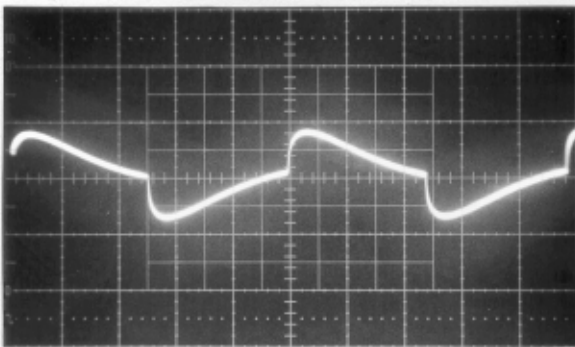

Fig. 3. Treble to 0.

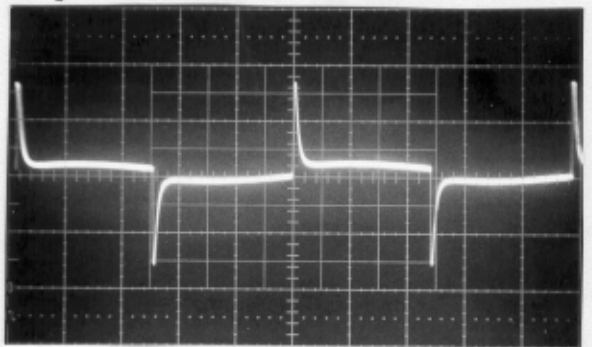

Fig. 7. Lo-Mid to 0.

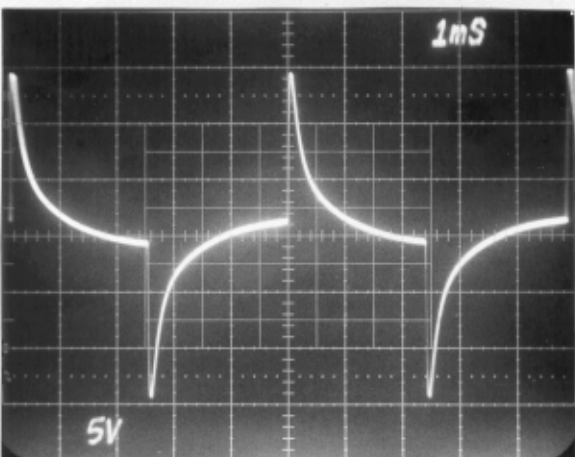

Fig. 4. Hi-Mid to 10.

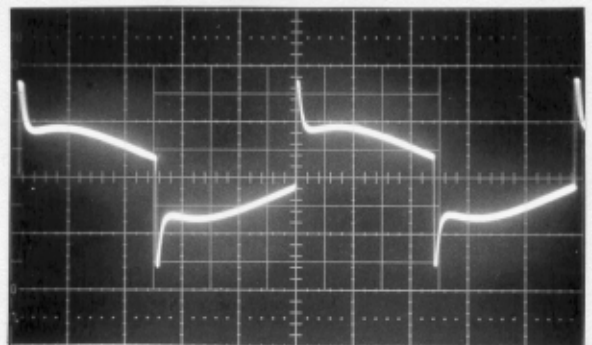

Fig. 8. Bass to 10.

-----BIAMP SWITCH IN:-----

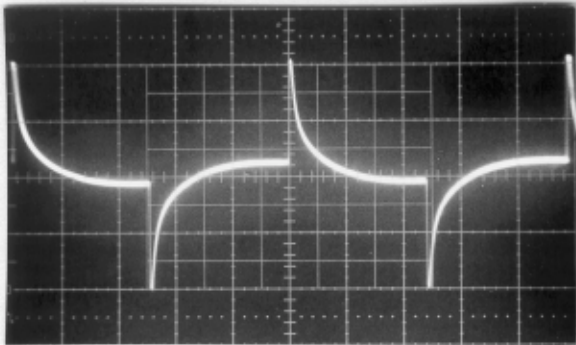

Fig. 9. Bass to 0.

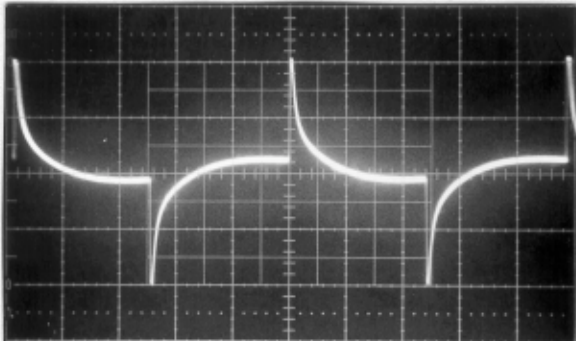

Fig. 10. Lo-Cut in.

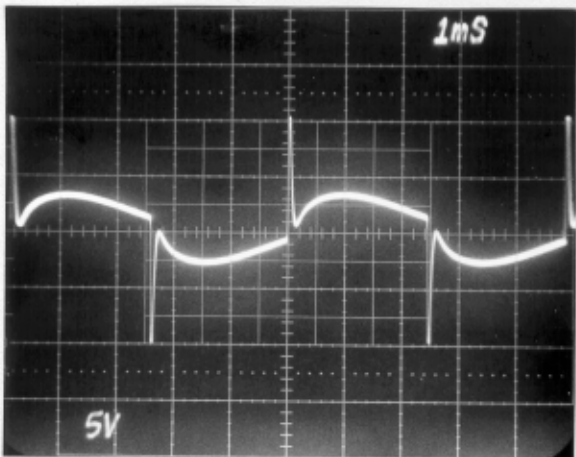

Fig. 11. Contour in.

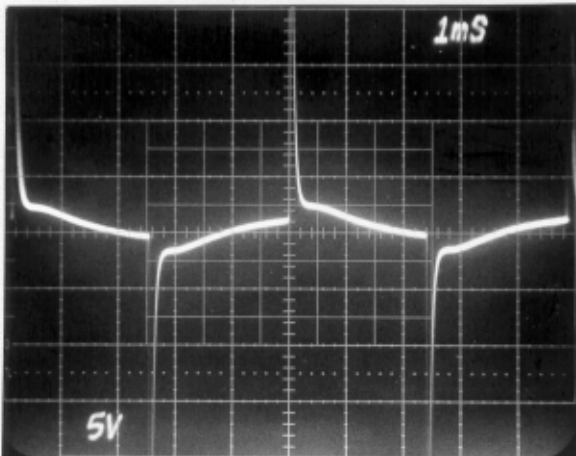

Fig. 12. Hi-Boost in.

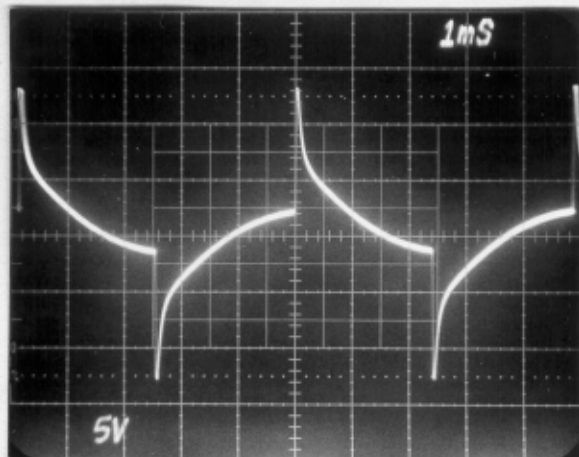

Fig. 13. 100W Amp - Freq at 0.

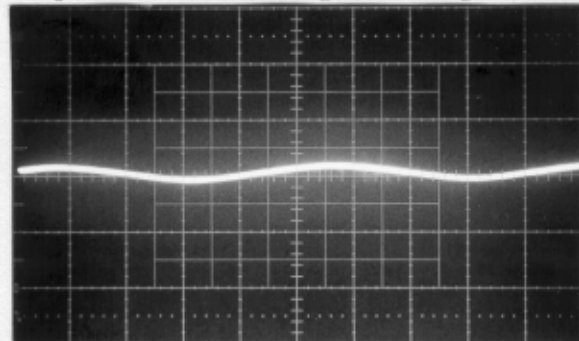

Fig. 14. 300W Amp - Freq at 0.

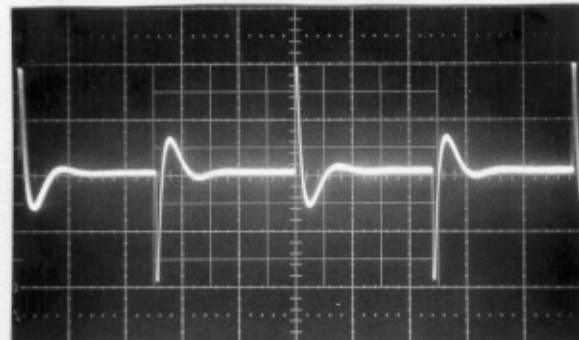

Fig. 15. 100W Amp - Freq at 10.

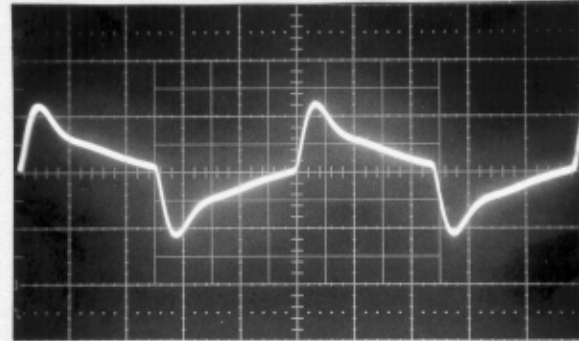
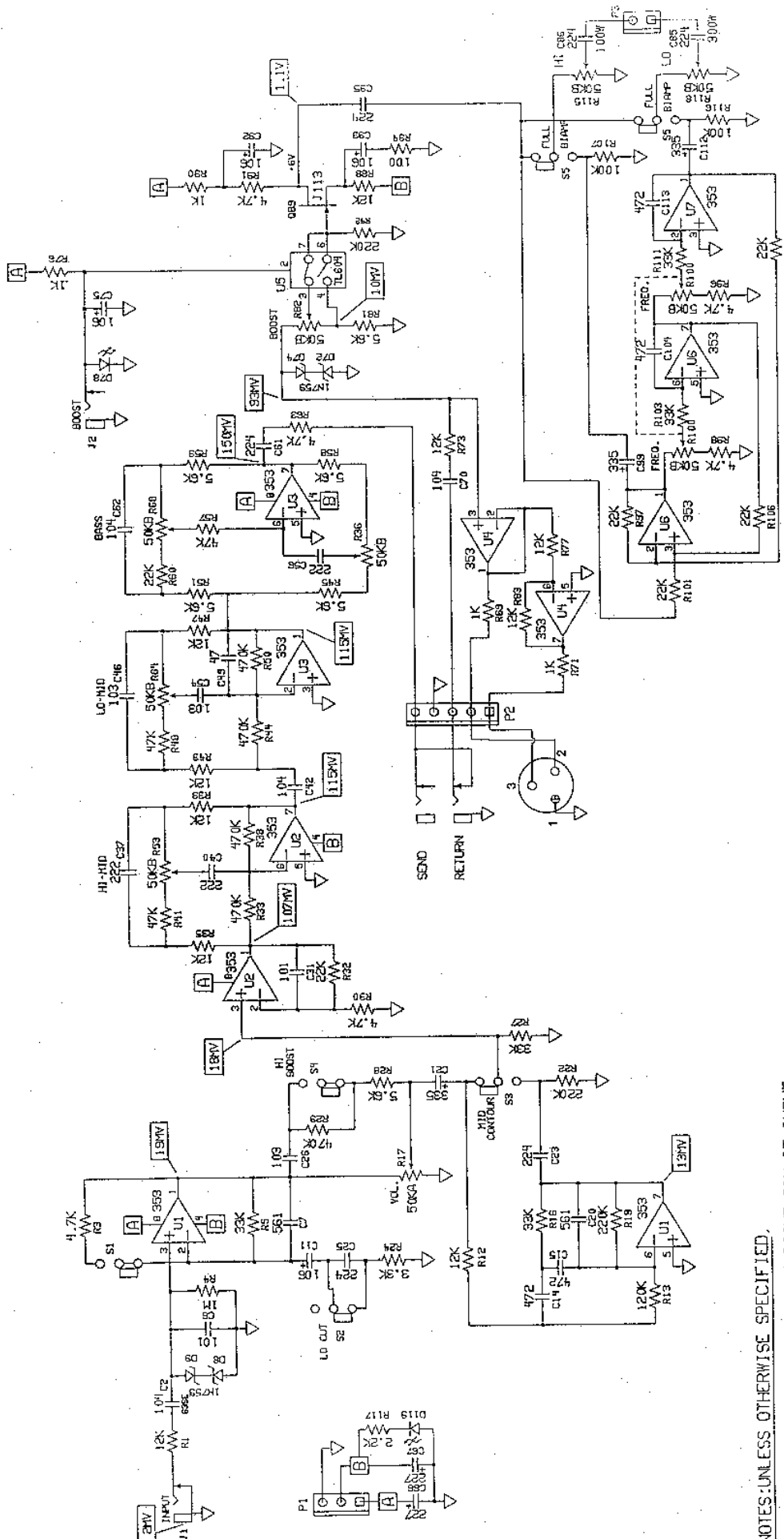

Fig. 16. 300W Amp - Freq at 10.



NOTES: UNLESS OTHERWISE SPECIFIED,

- TEST CONDITIONS: 20V 200HZ SIN AT INPUT
ALL TONE AND VOL ON 10
BOOST ON 10
ALL FILTERS OUT
- DENOTES RMS VOLTAGE.

PCOH#	DATE	FIRST SN	PCOH#	DATE	FIRST SN	PCOH#	DATE	FIRST SN	PCOH#	DATE	FIRST SN

GALLIEN-KRUEGER		MODEL #:	DESCRIPTION:	
		800RB	NEW 800RB PREAMP	
DESIGNED BY:	DATE:	PCOH-DATE:	FROM SN:	TO SN:
MPJ/RAG	8/13/91	406-0045-C		
SCHEMATIC	DBF:			
PG: 1 OF: 1	60045C			

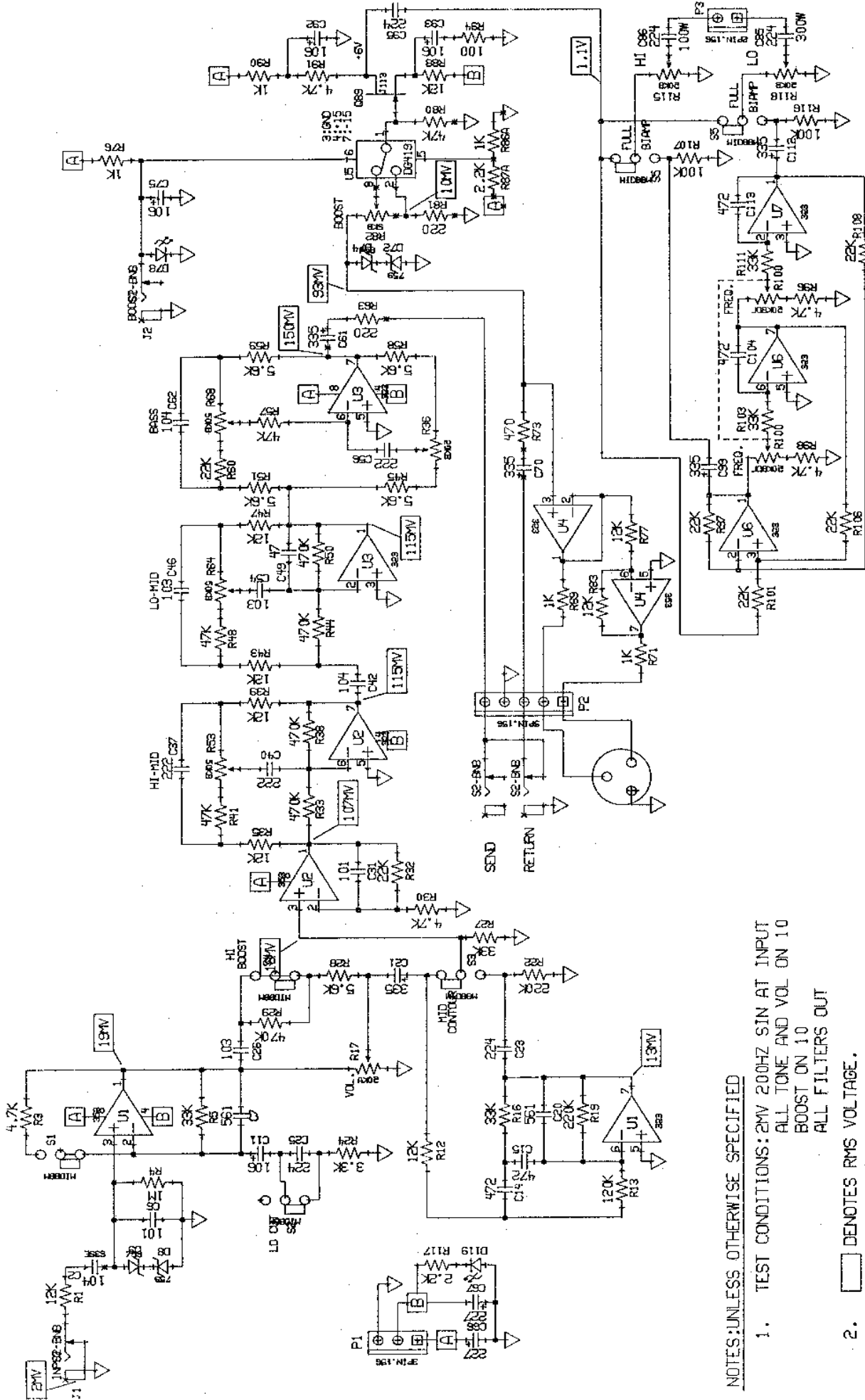

NOTES: UNLESS OTHERWISE SPECIFIED

1. TEST CONDITIONS: 2MV 200HZ SIN AT INPUT
ALL TONE AND VOL ON 10
BOOST ON 10
ALL FILTERS OUT
2. DENOTES RMS VOLTAGE.

PCO#	DATE	DESCRIPTION:
		GALLIEN TECHNOLOGY 408-441-8081
		2240 PARAGON, SAN JOSE, CA 95131
		MODEL #: 800RB
		DATE: 5/25/95
		DESCRIPTION: NEW 800RB PREAMP
		DESIGNED BY: MPJ/RAG
		REV#-DATE: 406-0045-D/E
		FOR: (COMPANY)
		GALLIEN-KRUEGER

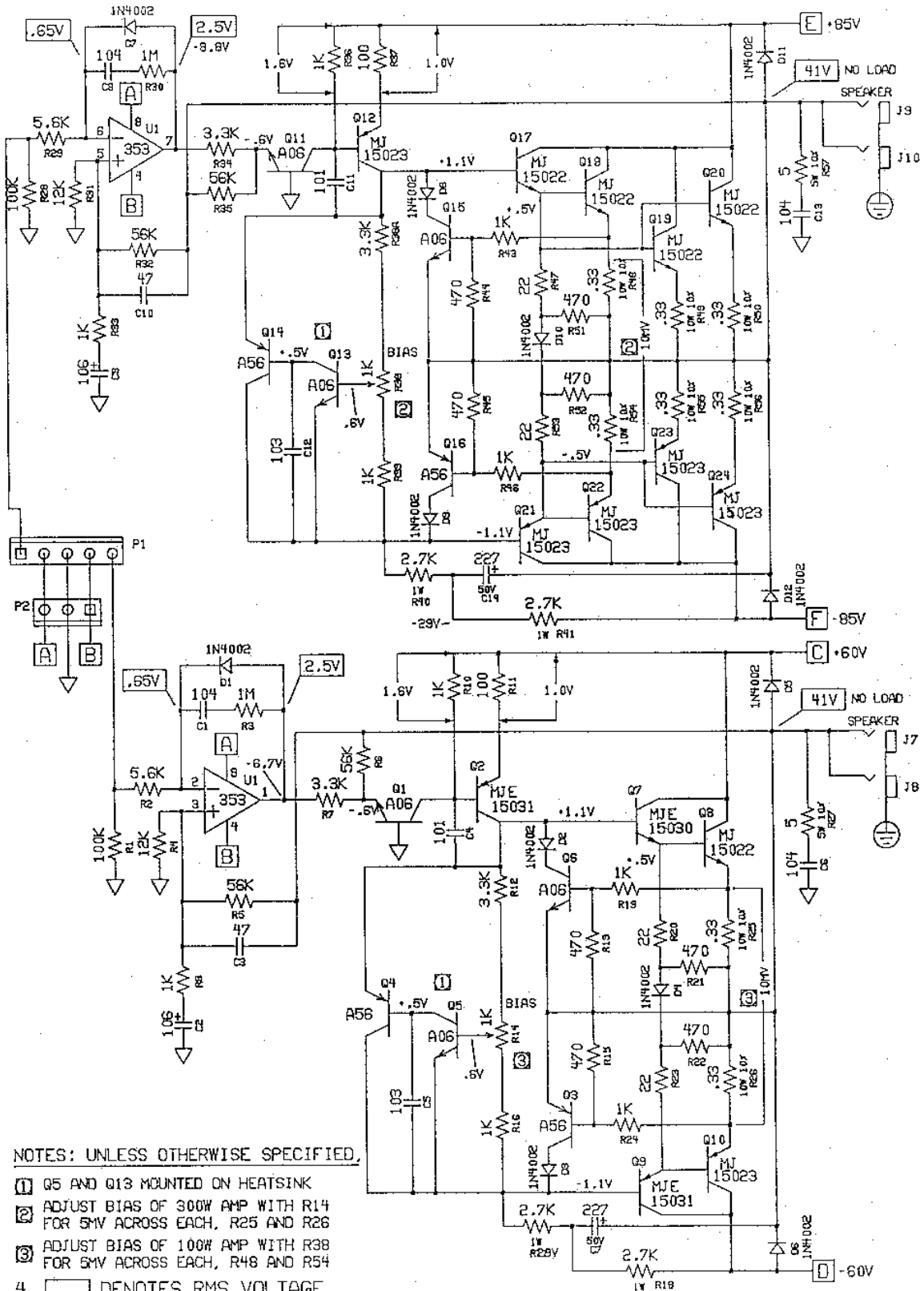

- NOTES: UNLESS OTHERWISE SPECIFIED,
- 1 Q5 AND Q13 MOUNTED ON HEATSINK
 - 2 ADJUST BIAS OF 300W AMP WITH R14 FOR 5MV ACROSS EACH, R25 AND R26
 - 3 ADJUST BIAS OF 100W AMP WITH R38 FOR 5MV ACROSS EACH, R48 AND R54
 - 4. DENOTES RMS VOLTAGE.

GK DOCUMENT #:	PCO#	DATE					
406-0044-B							
GALLIEN-KRUEGER		MODEL #:	DATE:	DESCRIPTION:			
		800RB	9/3/91	100W + 300W POWER AMPS			
SCHMATIC	DBF:	DESIGNED BY:	PART #:	PCO#-DATE:	FROM SN:	TO SN:	
PG:1 OF:1	60044AB	R.A.G.	0044A, 0044B				

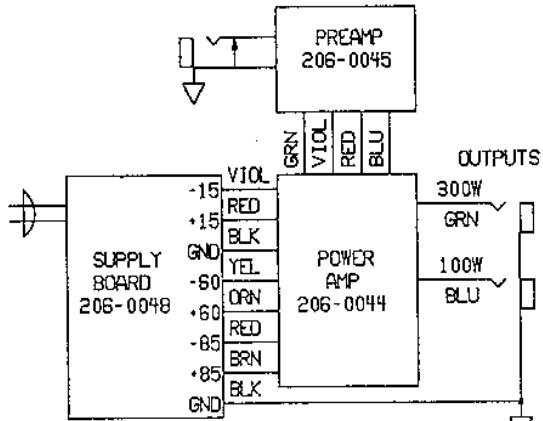
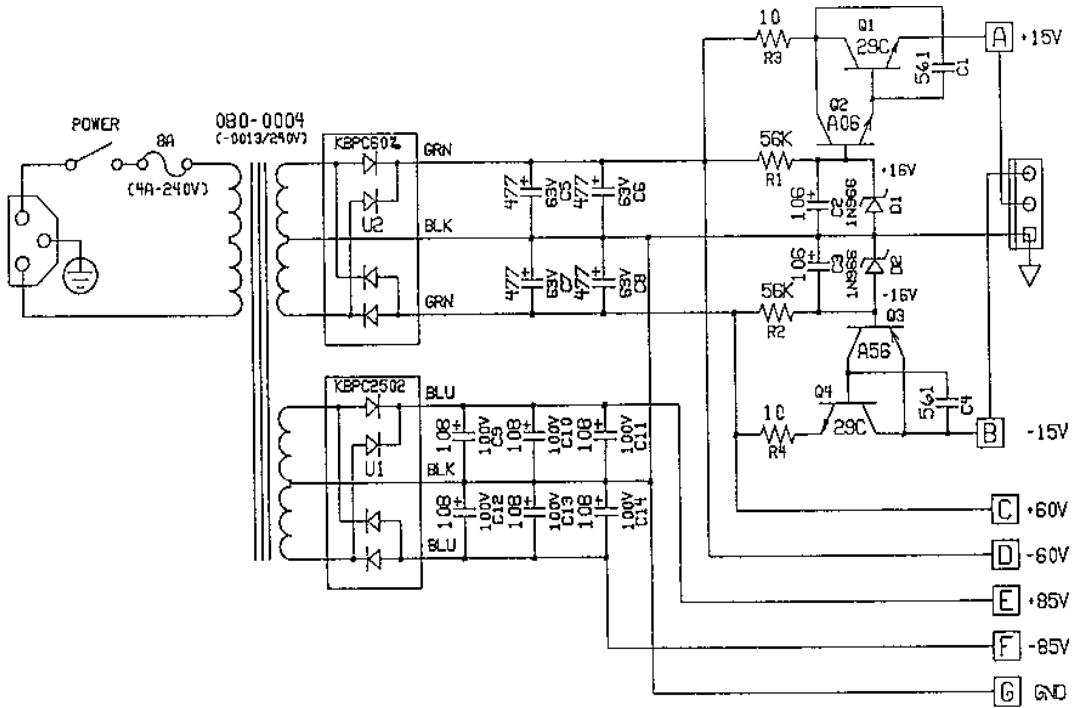

SUPPLY INTERCONNECTION DIAGRAM

GK DOCUMENT #: 406-0048-B	PCO#	DATE							
GALLIEN-KRUEGER		MODEL #: 800RB	DATE: 9/4/91	DESCRIPTION: 100W + 300W POWER SUPPLY					
SCHEMATIC PG: 1 OF: 1	DBF: 60048AB	DESIGNED BY: R.A.G.	PART #: 406- 0048A, 0048B	PCO#-DATE:	FROM SN:	TO SN:			

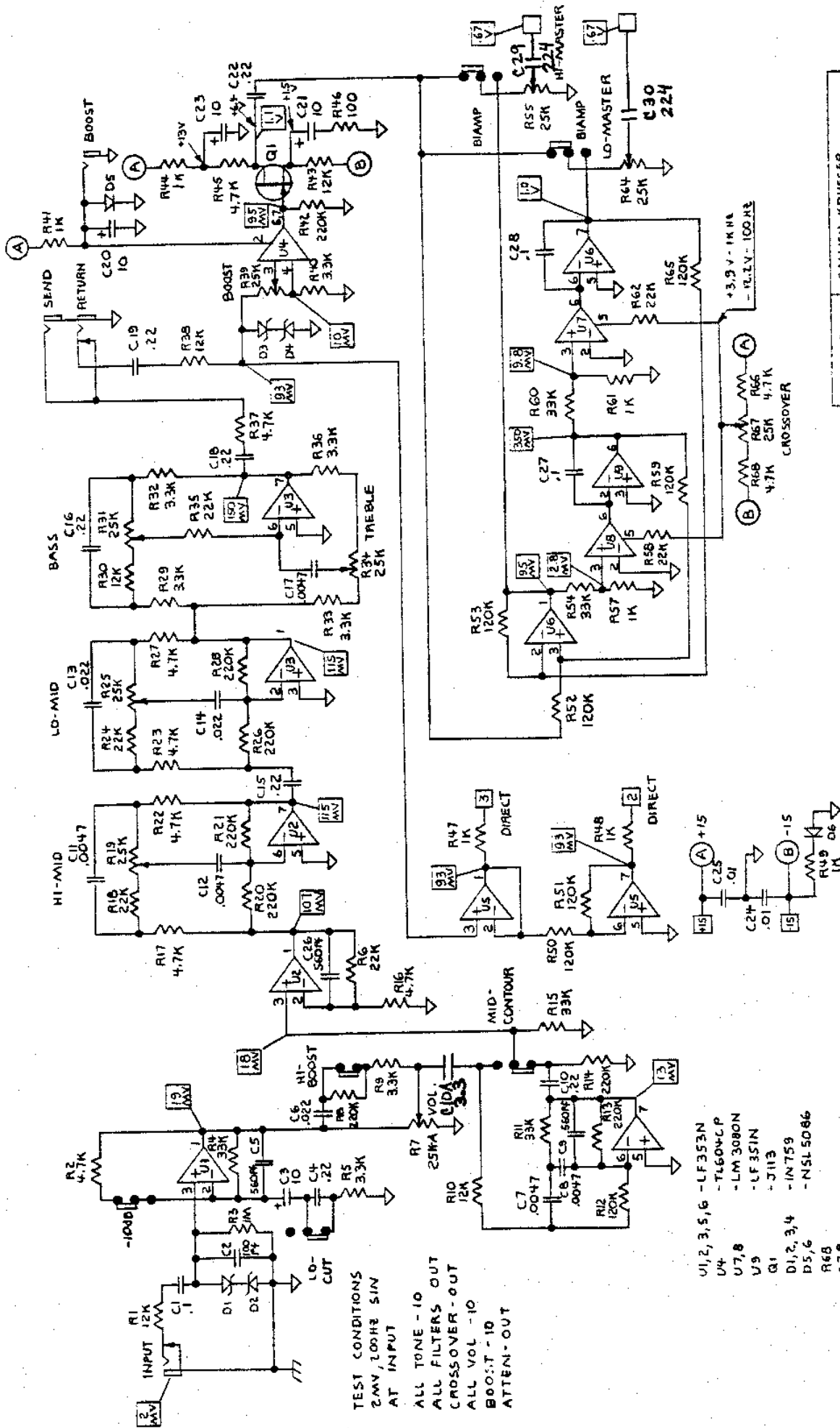

TEST CONDITIONS
 2MV, 100HZ SIN
 AT INPUT

ALL TONE -10
 ALL FILTERS OUT
 CROSSOVER - OUT
 ALL VOL -10
 BOOST -10
 ATTEN - OUT

- U1,2,3,5,6 -LF353N
 - U4 -TL604CP
 - U7,8 -LM3080N
 - U9 -LF353N
 - Q1 -3J13
 - D1,2,3,4 -1N759
 - D5,6 -1N5150B6
 - R68
 - C28
- ALL RESISTORS 1/4 W 5%, 01MS
 ALL CAPACITORS IN μ F UNLESS
 OTHER WISE SPECIFIED

10-18-82	GALLIEN-KRUEGER
BOB GALLIEN	BOB FAB PREAMP
SN-012714	60045 A

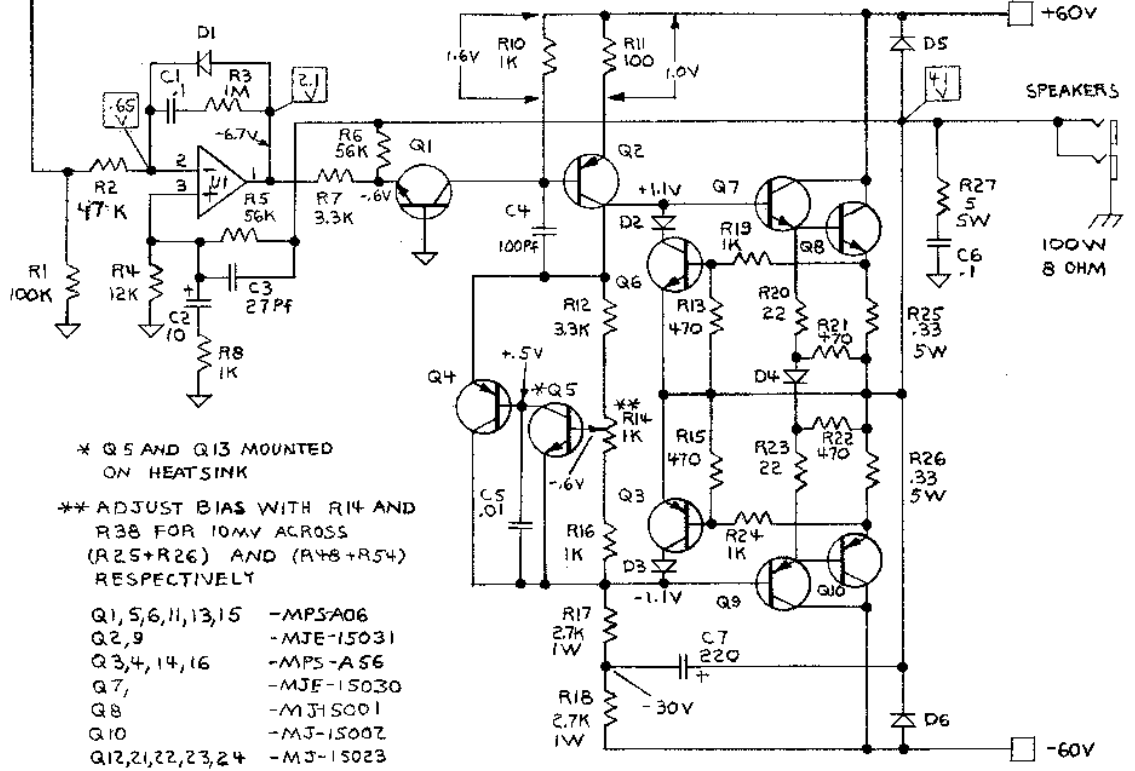
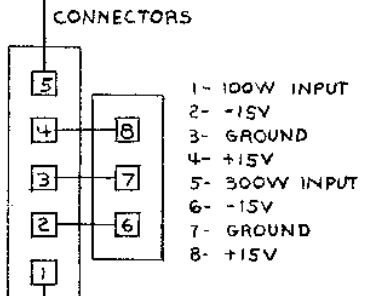
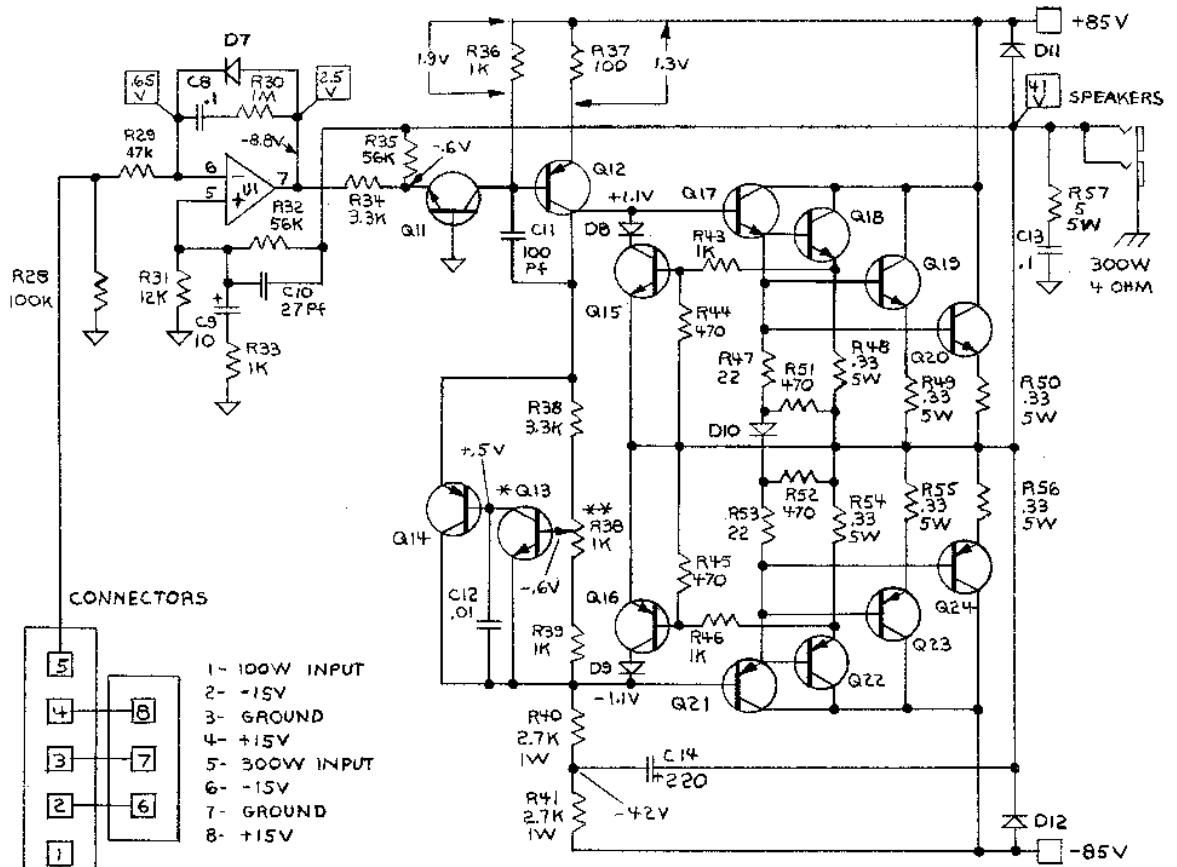

* Q5 AND Q13 MOUNTED ON HEATSINK

** ADJUST BIAS WITH R14 AND R38 FOR 10mV ACROSS (R25+R26) AND (R48+R54) RESPECTIVELY

Q1,5,6,11,13,15 -MPS-A06
 Q2,9 -MJE-15031
 Q3,4,14,16 -MPS-A56
 Q7, -MJE-15030
 Q8 -MJ15001
 Q10 -MJ-1500Z
 Q12,21,22,23,24 -MJ-15023
 Q17,18,19,20 -MJ-15022
 D1,2,3,4,5,6,7,8 -1N4002
 9,10,11,12 -LF353N
 U1 -LF353N

R-57
 C-14

-5-82	GALLIEN-KRUEGER
RA GALLIEN	100W/300W POWER AMP
SN-012714	SN-
	60044A

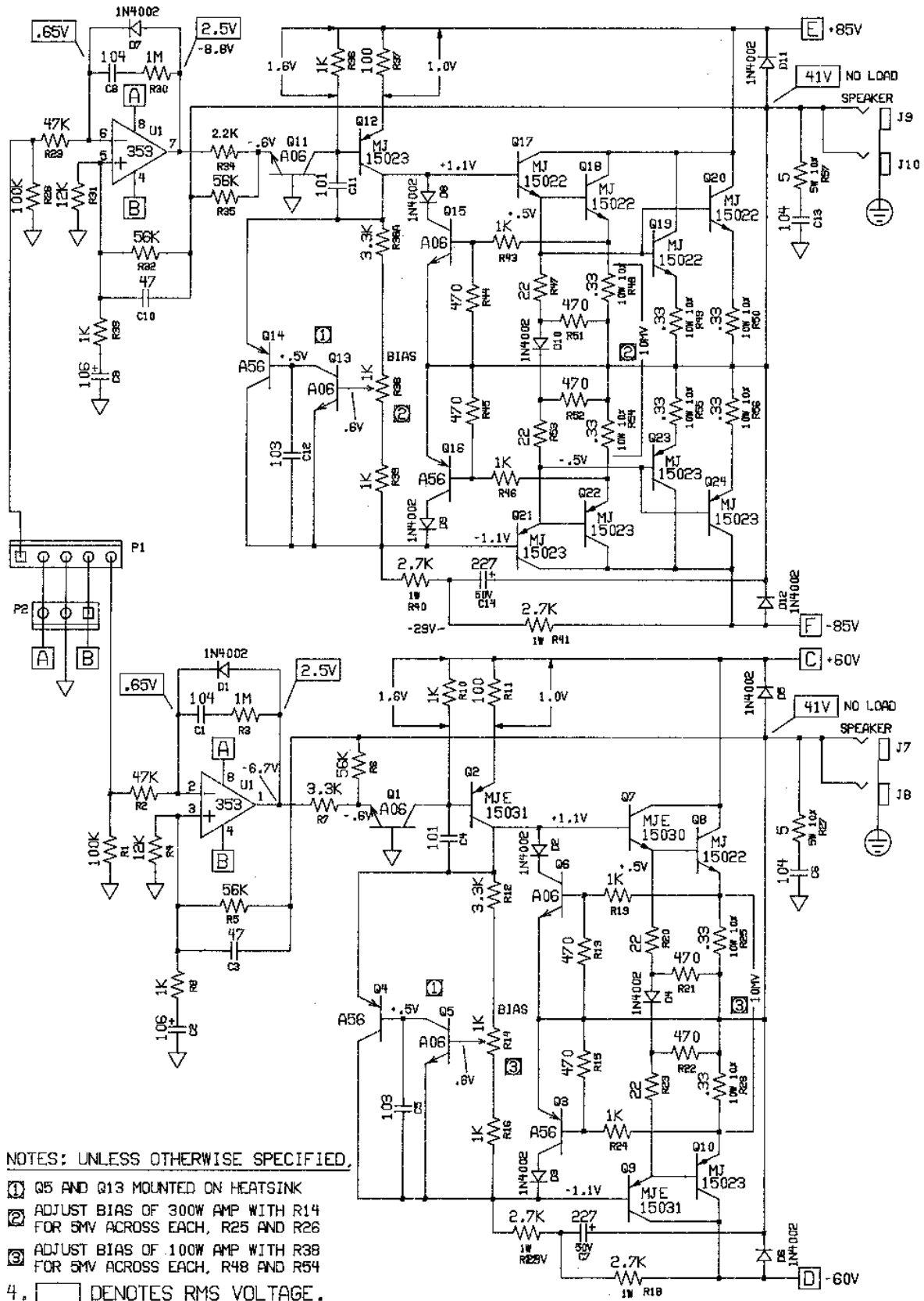

NOTES: UNLESS OTHERWISE SPECIFIED,
 1. Q5 AND Q13 MOUNTED ON HEATSINK
 2. ADJUST BIAS OF 300W AMP WITH R14 FOR 5mV ACROSS EACH, R25 AND R26
 3. ADJUST BIAS OF 100W AMP WITH R38 FOR 5mV ACROSS EACH, R48 AND R54
 4. DENOTES RMS VOLTAGE.

GK DOCUMENT #:	PCO#	DATE						
406-0044 -C		16 8/95						
GALLIEN-KRUEGER		MODEL #:	DATE:	DESCRIPTION:				
		800RB	4/1/92	100W + 300W POWER AMPS				
SCHEMATIC	DBF:	DESIGNED BY:	PART #:	PCO#-DATE:	FROM SN:	TO SN:		
PG:1 OF:1	60044C	R.A.G.	406-0044A, 0044C	16 - 8/95				

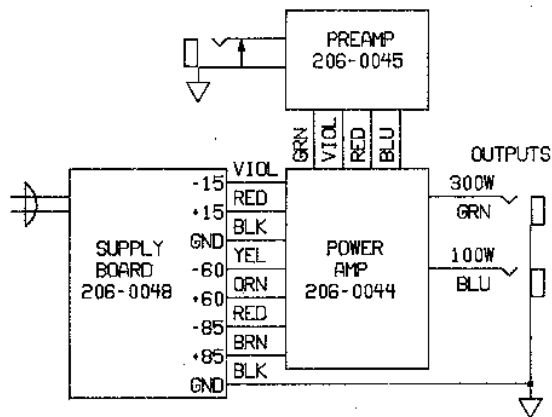
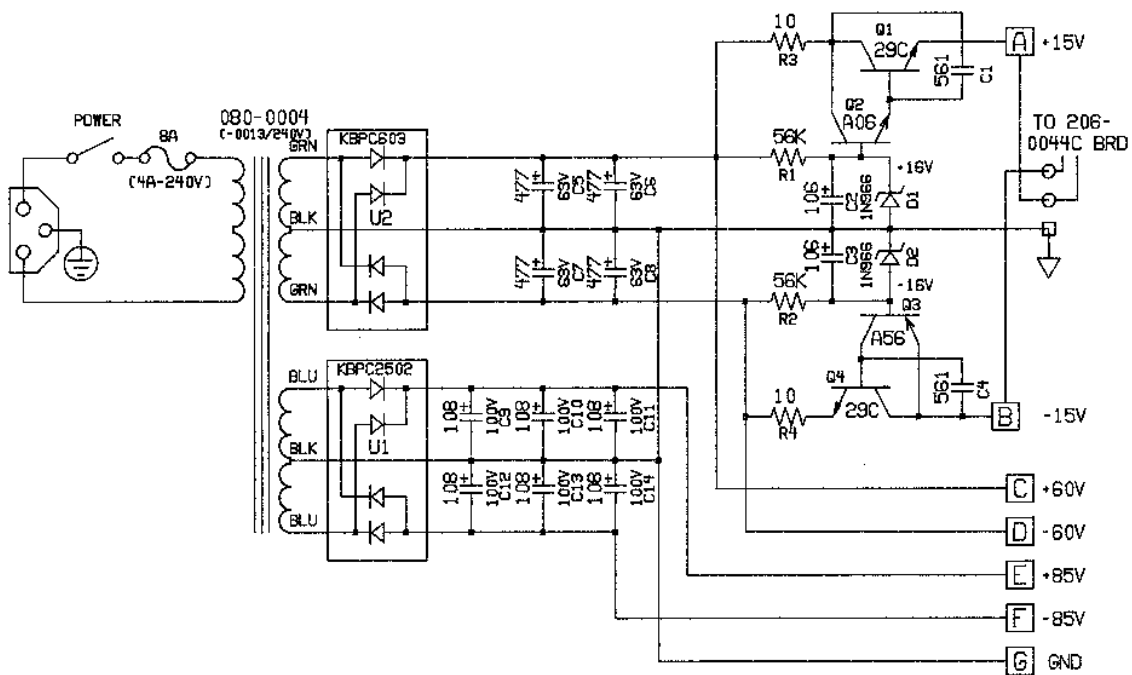

SUPPLY INTERCONNECTION DIAGRAM

GK DOCUMENT #:	PCO#	DATE											
406-0048-C													
GALLIEN-KRUEGER			MODEL #:	DATE:	DESCRIPTION:								
			800RB	4/1/92	100W + 300W POWER SUPPLY								
SCHEMATIC		DBF:	DESIGNED BY:	PART #:	PCO#-DATE:		FROM SN:	TO SN:					
PG: 1 OF: 1		60048C	R.A.G.	406-0048A, 0048C									

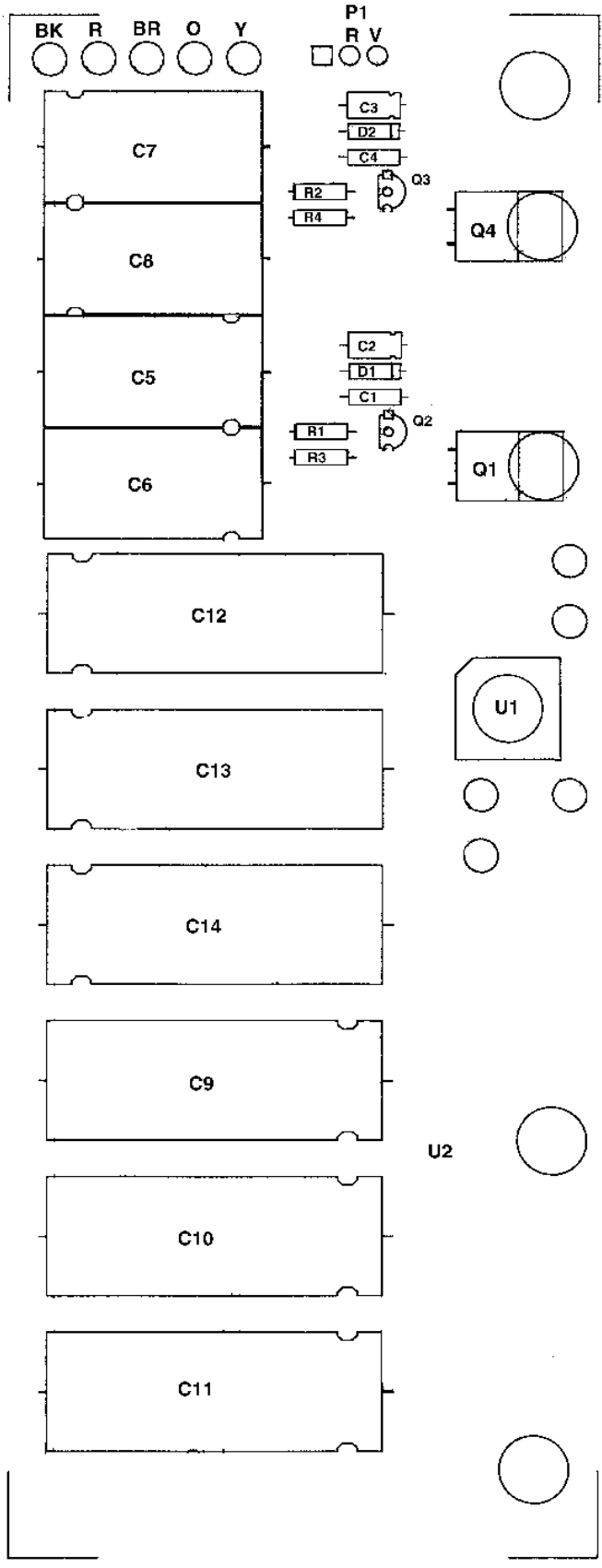

PCO#	DATE

GALLIEN-KRUEGER		MODEL #:	800RB	DATE:	3/30/92	DESCRIPTION:	NEW 800RB POWER SUPPLY
CIRCUIT BOARD	DBF:	DESIGNED BY:	R.A.G.	BOARD #:	206-0048-C	REV#-DATE:	FROM SN: TO SN:
ARTWORK	50048C						

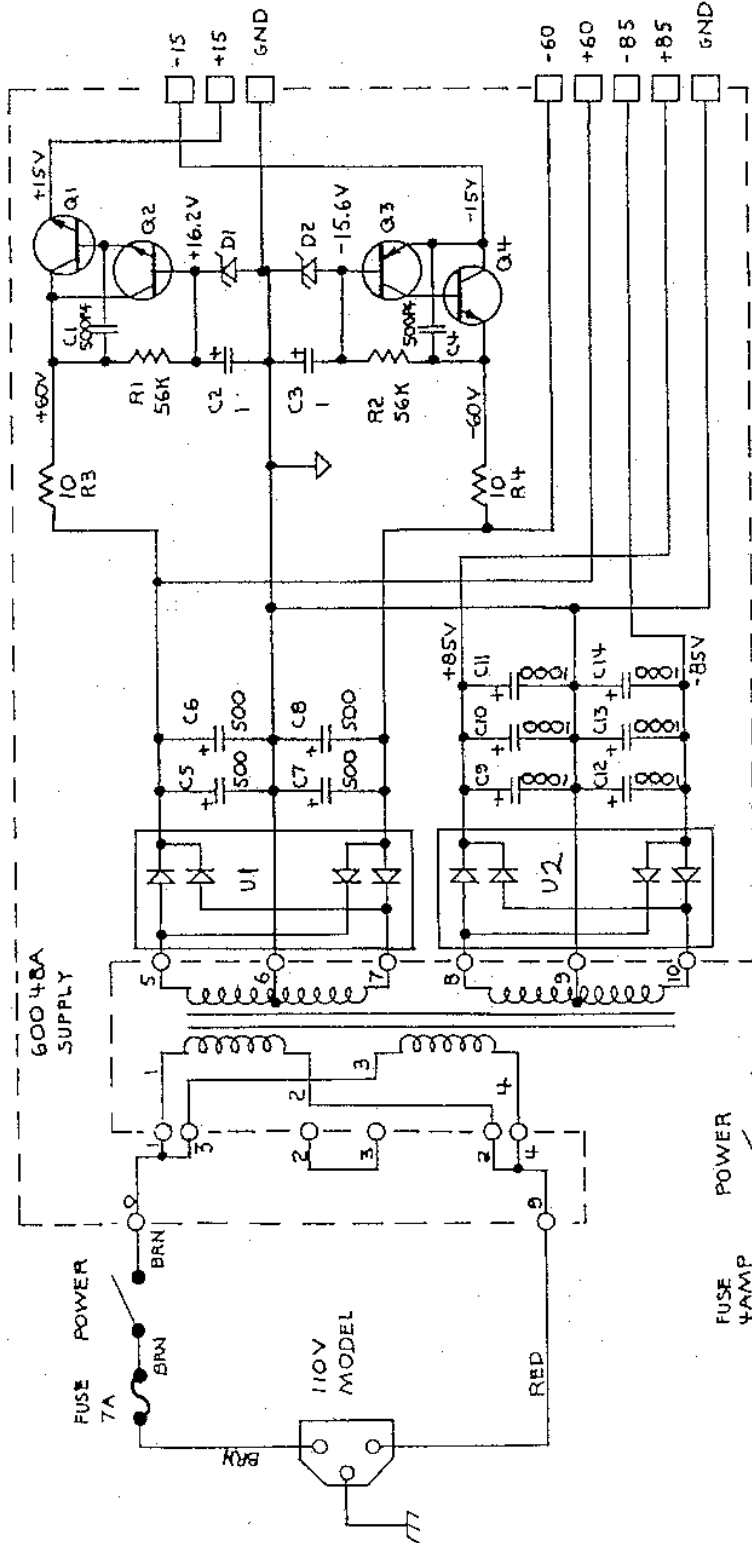

- USED ON:
- Q1,4 - TIP 31B
 - Q2 - MPS-A06
 - Q3 - MPS-A56
 - D1,2 - 1N966
 - F1,2 - 275.125
 - U1 - KBPC-102
 - U2 - KBPC-2S02

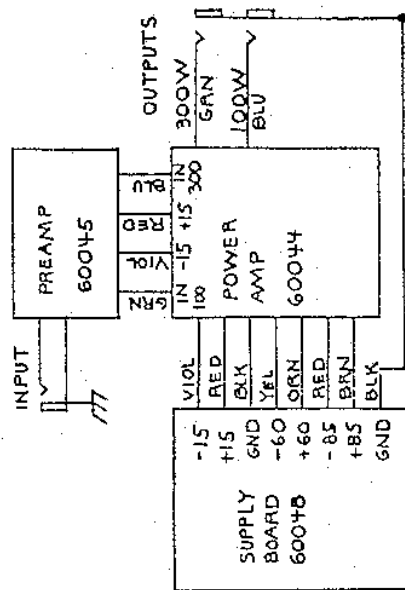

SUPPLY INTERCONNECTION DIAGRAM

11-9-82	GALLIEN-KRUEGER
R.A. GALLIEN	100/300 SUPPLY
SN-012714	SN- 60048A

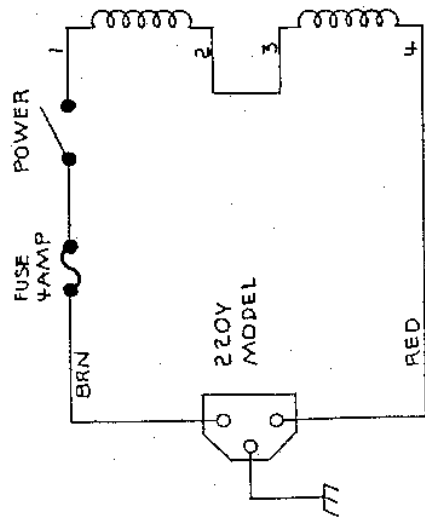

- 1-BRN
- 2-RED
- 3-ORN
- 4-YEL
- 5-GRN
- 6-BLK
- 7-GRN
- 8-BLU
- 9-BLK
- 10-BLU

GALLIEN-KRUEGER
403-0045 REV C6

COMPONENT SIDE SHOWN

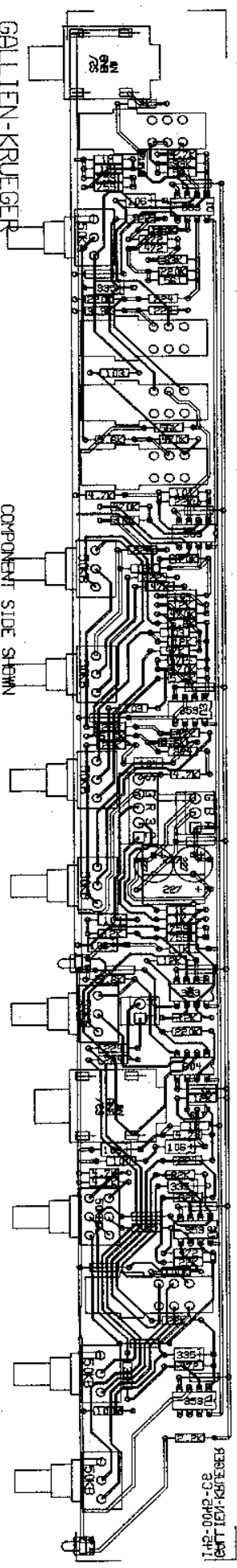

Ref. Desig.

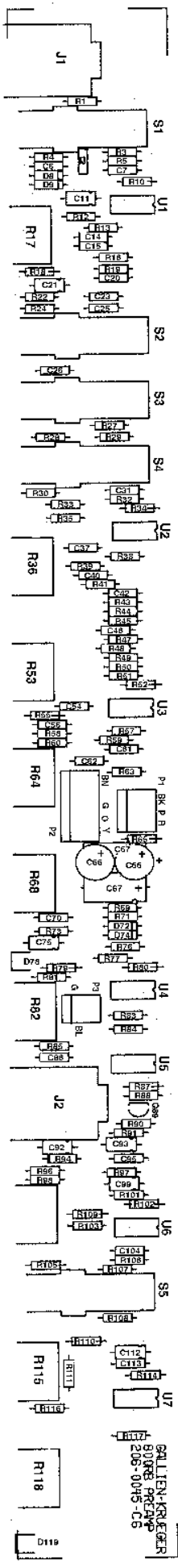

Values

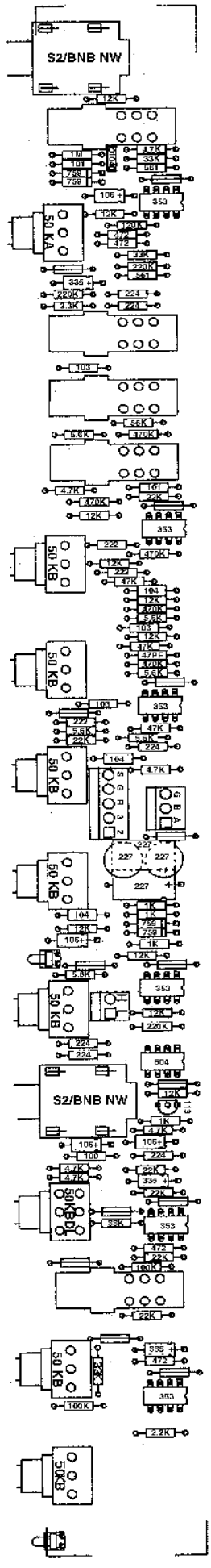

GALLIEN-KRUEGER		MODEL #:	DATE:	DESCRIPTION:
CIRCUIT BOARD		800RB	1/8/92	NEW 800RB BOARD
PARTWORK		50045C6	MPJ/RAG	REV#-DATE: FROM SN: TO SN: