

Service Manual

Backline 100

Table of Contents

Operating Instructions	3
Turn On / Calibration Procedure	7
Schematics	9
Engineering Change Orders (ECOs)	17
Bill of Materials	24



OPERATING INSTRUCTIONS

BackLine 100 Guitar Amplifier

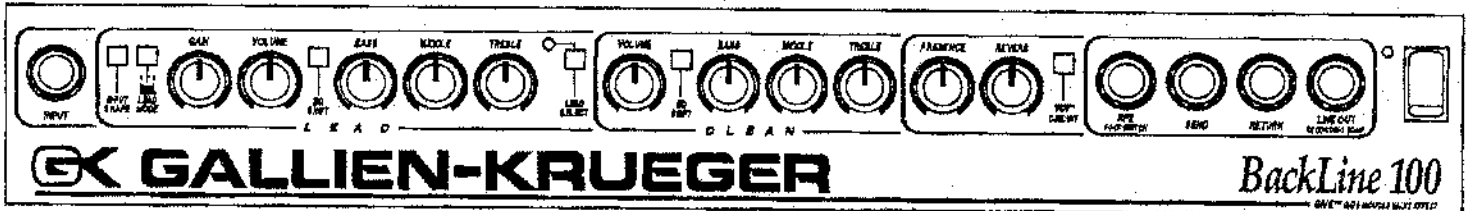

A WORD ABOUT YOUR NEW AMPLIFIER

Over 20 years ago, Bob Gallien's first product, the 226A Guitar Amplifier was on the backline at Woodstock. It was the beginning of a long line of top quality guitar amplifiers whose reputation still holds strong today. Following in that tradition, the BackLine 100 combines time-honored features such as 3-spring reverb and passive equalization with Gallien-Krueger developments like GIVE™ technology, channel switching, and VCV™ recording compensation, to achieve a perfect blend of vintage and modern technologies.

GIVE™ (Gate Induced Valve Effect) is the culmination of Bob Gallien's twenty-five year pursuit - to optimize the superior qualities inherent in field effect devices for audio applications. Beginning in the '60s, while still an engineering student at Stanford, Bob began using field effect devices in the critical signal path areas of his amplifier designs. Each design since then has yielded new discoveries and improvements in the sound. The BackLine 100 has been developed around the latest and most comprehensive use of what we now call GIVE TECHNOLOGY. This design

provides the smooth overdrive and even harmonic distortion characteristics common to vintage tube amplification without the hassles and expense of tube failures. The result is a punchy, warm clean sound, and a hot, out-front lead sound that gets the most out of your playing.

Integrated with GIVE™ are a host of intelligent features developed by Gallien-Krueger engineers that make the BackLine an ideal amp for the nineties. Input Shape, separate equalizers (with shift) for each channel, presence, and VCV™ filtering combine to make the BackLine a sound monster. Add three channel operation, through the Lead 1/Lead 2 feature, and you get an amp that gives you anything you want, from clean, to crunch, to lead, and it will do it with virtually any guitar, and any speaker system.

VCV™ (Vintage Cabinet Voicing) has been a part of Gallien-Krueger amps for over ten years. Originally it was designed to make the 250ML sound big, even through its dual 6" speakers. Now it is a selectable feature on the BackLine 100. So whether you are recording, using headphones, using a small speaker or a stack, you will always have that big sound.

Twenty-five years of continuous

improvement are also apparent in the BackLine 100 power amp. Bob has perfected a constant current amplifier that interacts with the speaker to produce the low end "thump" and high end brilliance needed to put your guitar sound out front. In addition, the new power amp will integrate the output current to zero in the event of an output short. When the short is removed, the amp is ready to go again. You don't have to worry about an accidental short blowing your gig.

The dictionary defines Paragon as a *model of perfection*. That is the only fitting description for the speaker Gallien-Krueger designed for the BackLine 100. The 100 watt Paragon 12" guitar speaker will keep its cool when you push it, and deliver a sound with all the warmth and tone you expect from Gallien-Krueger. The exceptional Paragon speaker is also available in a full line of speaker cabinets from Gallien-Krueger.

We are proud of the BackLine 100 and feel it has passed its final test with your purchase. This manual is intended to familiarize you with the operation and features of your new amplifier. If used properly, it should give you years of musical enjoyment and trouble-free service.

CAUTIONS

- TO PREVENT ELECTRICAL SHOCK OR FIRE HAZARD, DO NOT EXPOSE THESE UNITS TO RAIN, MOISTURE OR EXCESSIVE HEAT.
- IF SERVICE ON YOUR AMPLIFIER IS NECESSARY, PLEASE REFER TO A GK AUTHORIZED SERVICE CENTER. DO NOT ATTEMPT TO REMOVE PROTECTIVE COVERS FROM THE AMPLIFIER OR SERVICE THE AMP YOURSELF. LETHAL CONDITIONS EXIST INSIDE!
- FOR OPTIMUM PERFORMANCE OF YOUR NEW AMPLIFIER, PLEASE READ AND FOLLOW INSTRUCTIONS IN THIS MANUAL CAREFULLY.

GK GALLIEN-KRUEGER

BACKLINE 100 FRONT & REAR PANELS

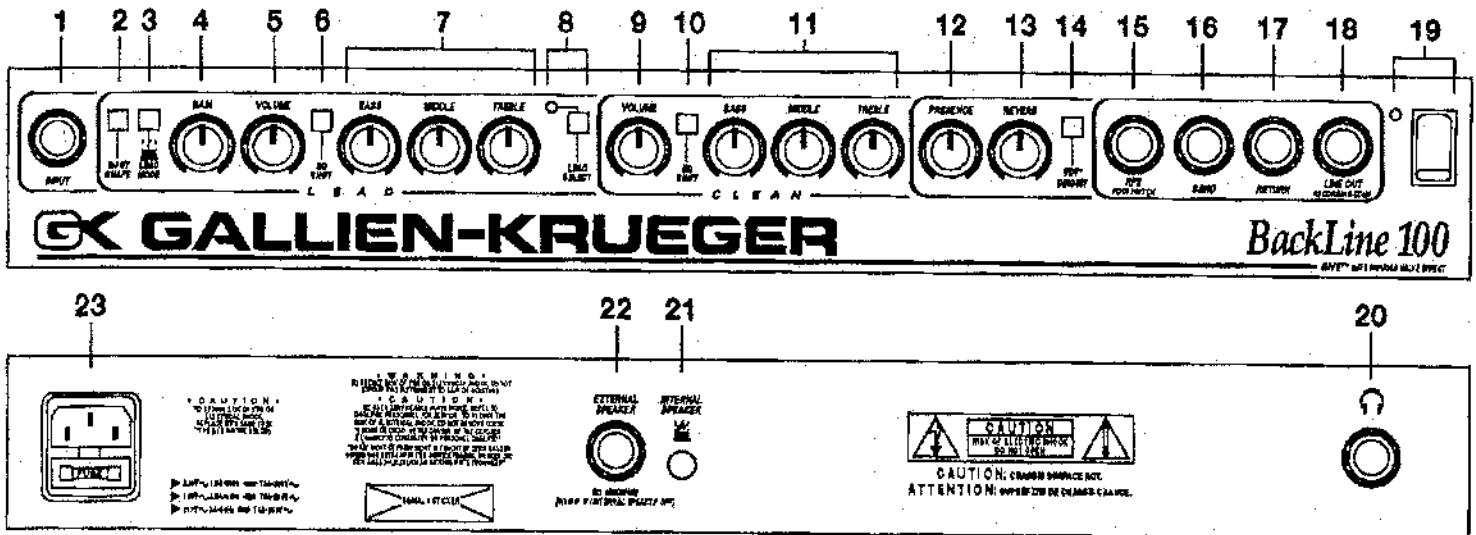

FRONT PANEL FEATURES

- 1 • INPUT JACK**
Accepts a standard 1/4" phone plug and a signal level up to +4 dBV.
- 2 • INPUT SHAPE**
A "pre-distortion" filter which, in the "out" position, rolls off the very low frequencies to prevent muddy sounding distortion at high gain levels. When "in" it boosts the bass for a better low gain sound.
- 3 • LEAD MODE (1-2)**
Lead 1 (out) provides lower gain for a blues sound or crunch rhythm, while Lead 2 (in) is for high gain overdrive and lead soloing.
- 4 • GAIN**
Used in conjunction with Lead Mode it can vary the sound from a slight overdrive to high gain saturation with fuller harmonics and increased sustain.
- 5 • VOLUME**
Sets the overall Lead Channel volume coming out of the speaker(s) or headphones.
- 6 • EQ SHIFT**
Shifts the operating frequencies of the equalizer section to provide a boost in the high-midrange.
- 7 • THREE-BAND PASSIVE EQUALIZER**
Located after the distortion stages for maximum effect, it provides tone control over 3 frequency ranges - low, middle, and high - specifically suited for an overdriven guitar tone.
- 8 • LEAD SELECT SWITCH & LED**
Pushing this switch in will light the LED to indicate that the amp is in the Lead Mode.
- 9 • VOLUME**
Sets the overall Clean Channel volume level at the output. Use in conjunction with the Lead Volume to balance the level of each channel for channel switching.
- 10 • EQ SHIFT**
Shifts the operating frequencies of the equalizer - in this case, it provides more bass for a mellower sound.

- 11 • THREE-BAND PASSIVE EQUALIZER**
Provides tone control over three frequency ranges specifically suited for a clean guitar tone.
- 12 • PRESENCE**
Affects the very high frequency range controlling the "edge" of a lead tone and the brightness of a clean sound.
- 13 • REVERB**
Controls the amount of signal coming from the built-in 3-Spring Reverb that is to be mixed with the dry signal.
- 14 • VCV™ CIRCUIT SWITCH**
The VCV™ (Vintage Cabinet Voicing) filter provides a bass boost, a high-mid peak, and a high frequency roll-off that simulates a speaker being miked and is very useful in recording direct to tape. This switch allows that same filter to be switched in for use in the speaker and the headphones.
- 15 • RF2 FOOTSWITCH JACK**
This jack accepts a 1/4" stereo plug for connection to the RF2 footswitch which allows remote switching between Clean and Lead channels and Lead 1/Lead 2 when Lead Channel is selected. NOTE: LEAD MODE and LEAD SELECT should be pushed in for RF2 operation.
- 16 & 17 • EFFECTS LOOP**
Provides a means of adding in-line effects (see *Sample Hook-ups*). The Send can also be used as a preamp output with no recording compensation.
- 18 • LINE OUT (RECORDING COMPENSATED)**
Provides a line-level signal with VCV™ filtering - useful for going direct to a PA mixer or studio recorder.
- 19 • POWER SWITCH & LED**
Turns unit on (I) and off (O). LED turns on to indicate power is on. Unplug unit if not being used for extended periods.

REAR PANEL FEATURES

- 20 • HEADPHONE JACK**
Brings the power amp signal to a level that allows standard headphones to be driven. The VCV™ is recommended for headphone operation.
- 21 • INTERNAL SPEAKER SWITCH**
Allows internal speaker to be turned off (in "out" position) for use with headphones or silent direct recording or if the unit is used for driving a larger 4 ohm cabinet such as a 4 x 12". NOTE: No damage will result from operating the amplifier with the speaker disconnected.
- 22 • EXTERNAL SPEAKER JACK**
Allows external speakers to be driven by the internal power amp. For optimum performance and to avoid damaging the amplifier, use the following minimum external speaker impedances:
INTERNAL SPEAKER "ON": 8 ohm minimum total external impedance.
INTERNAL SPEAKER "OFF": 4 ohm minimum total external impedance.
- 23 • AC RECEPTACLE & FUSE HOLDER**
This combination grounded AC jack and fuse holder accepts a detachable power cord. If a replacement is needed, it should be UL rated at 10 amps/125VAC or 5 amps/240VAC. Never operate this amplifier with any other than the recommended fuse type: 5mm x 20mm, slow blow, 250V with ampere ratings as follows:

Line Voltage	Fuse Rating	Fuse #
100VAC	5 Amps	T5A-250V
117VAC	4 Amps	T4A-250V
230VAC	2 Amps	T2A-250V

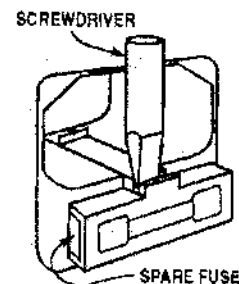

To replace fuse, simply slide out the fuse holder using a screwdriver, as shown on the left. A spare fuse is located in a sliding compartment directly behind the embossed fuse symbol.

GETTING STARTED

- 1 • Plug your guitar into the input jack and make sure all of its volumes and tone controls are set to "10". You can fine tune them later.
- 2 • On the BackLine 100 - Start with the tone controls and Presence control in the center position (12 o'clock), all other controls on "0", and all switches out.
- 3 • Gradually turn up the "Clean Volume" control, while playing, and set to desired level.
- 4 • Experiment with the EQ Shift and tone controls for your desired clean sound. Then add Presence, Reverb, or the VCV™ filter to suit your tastes.
- 5 • Switch to the Lead Channel by engaging the Lead Select switch.
- 6 • This time, turn up the "Lead Volume" slightly and then increase the Gain until you have found a suitable gain level (you may want to experiment with the Lead 1/Lead 2 switch and the Input Shape at this time, as well). Then continue to set the Volume for a proper output level.
- 7 • Again, follow the steps from 4 to fine-tune your sound. There are many settings to experiment with here, and you should try as many possibilities as you can because you will probably find a number of them that are very pleasing.
- 8 • To help familiarized yourself with the BackLine 100's controls, you may want to use the selected settings (shown on the right) as a starting point. Please take note that these settings are designed for specific guitar body types as well as pickup configurations. Enjoy.

SELECTED SETTINGS (ON RIGHT)

- Controls shown in black are active or in the "in" position.
- Volume settings will be somewhat dependent on speaker configurations, desired volume level, and outboard effects.
- Settings are intended for the BackLine 100 Combo as well as the BackLine 100 Head.

Strat is a registered trademark of Fender. Les Paul is a registered trademark of Gibson.

FULL BODIED CLEAN • Strat, Middle Pickup



BRIGHT CLEAN • Strat, Bridge & Middle Pickups

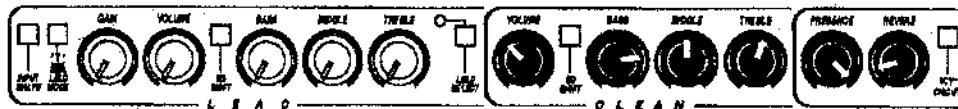

MELLOW CLEAN • Les Paul, Bridge & Neck Pickups

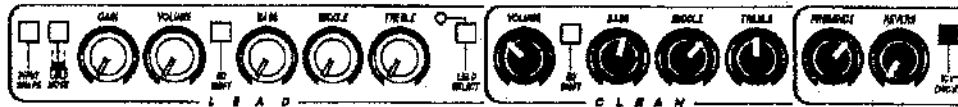

PUNCHY BLUES • Strat, Bridge & Middle Pickups

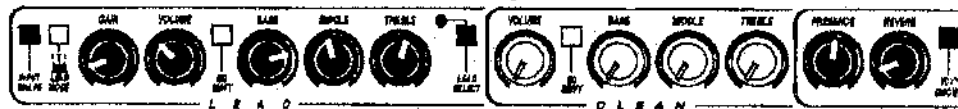

CRUNCH RHYTHM (switch to Lead 2 Mode for leads) • Les Paul, Bridge Pickup

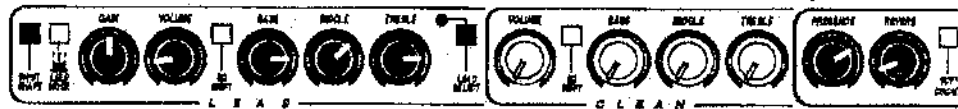

METAL OVERDRIVE • Les Paul, Bridge Pickup



DRIVING LEAD • Strat, Bridge Pickup

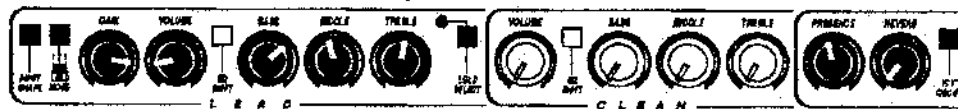

DARK "GRUNGE" TONE • Les Paul, Bridge Pickup

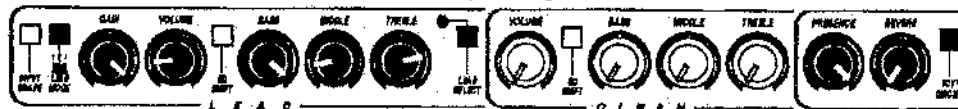

SAMPLE HOOKUPS

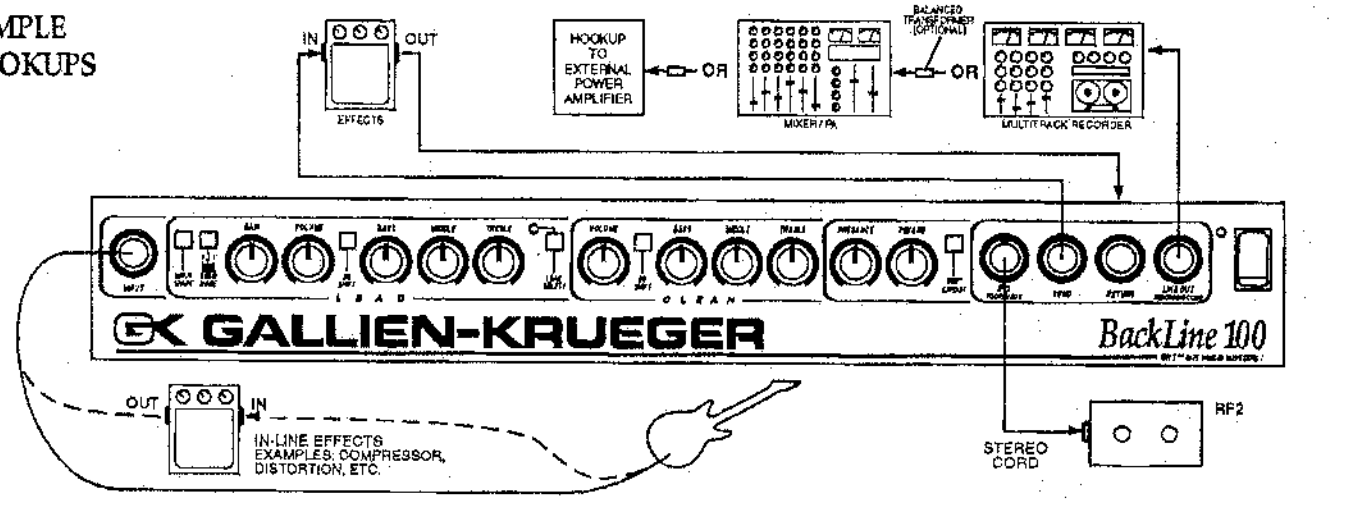

SUGGESTED GALLIEN-KRUEGER SYSTEMS

Putting together the right system is as important to your final sound as choosing the right amplifier or the right guitar. Here are our favorite systems, each designed to optimize the power and versatility of the BackLine 100 Combo and Head. For the ultimate system, use GK cabinets, the only cabs specifically designed for GK electronics.

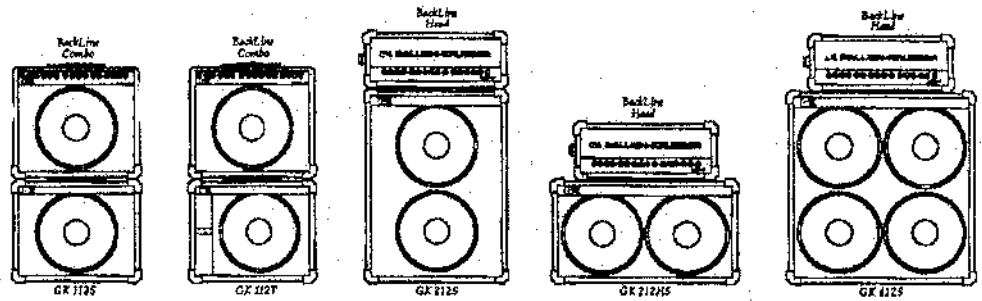

BACKLINE 100 BLOCK DIAGRAM

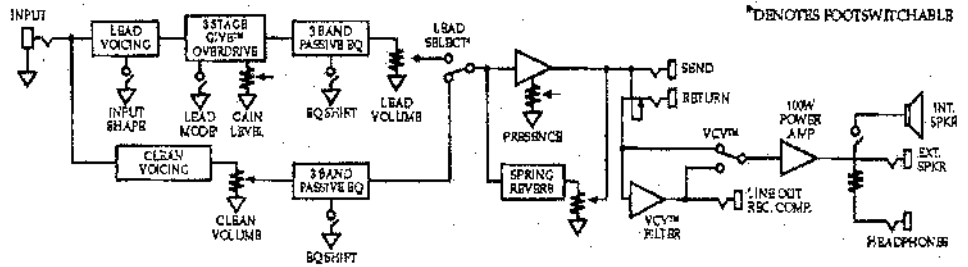

SPECIFICATIONS

Max Input: 1.4Vrms
Output: 70W into 8Ω
 100W into 4Ω
 (@ less than 5% THD)
Signal-to-Noise Ratio: (Clean Channel) 35mVrms @ 1KHz
 (Lead Channel) 4mVrms @ 1KHz
Return Sensitivity: 58Vrms @ 1KHz
Clean Equalization: Mid: +4, -5 dB @ 400Hz
 w/Shift: +3, -6 dB @ 700Hz
 Treble: +6, -12 dB @ 2KHz
 Bass: +4, -10 dB @ 80Hz

Lead Equalization: Mid: +4, -8 dB @ 800Hz
 w/Shift: +3, -5 dB @ 500Hz
 Treble: +5, -6 dB @ 4KHz
 Bass: +2, -3 dB @ 80Hz
Presence: +2, -3 dB @ 4KHz
Input Impedances: Input.....1MΩ
 Return.....100KΩ
Output Impedances: Send.....3KΩ
 Line Out (Recording Compensated).....1KΩ
Reverb: 3-Spring Accutronics
Dimensions: 112 Combo: 19"W x 17"H x 12"D (42 lbs.)
 Head: 21.2"W x 9"H x 9.7"D
Footswitch: GK RF2 and standard 3-connector stereo cord (1/4" plugs)

TROUBLESHOOTING

Your new amp, if handled with care, should give you trouble-free performance. If operated according to instructions in this manual, your only maintenance should be occasional external cleaning.

Often when an electrical component provides poor, erratic, or no performance, it is due to minor problems or irregularities which may be corrected easily by someone knowing very little about electronics.

We have provided the accompanying chart for your reference. If you have any problems at all, please check this list first. If your problem is major and there is definitely something wrong with the unit, please refer to the list of GK Authorized Service Centers included with the paperwork in the packing box. If necessary, call your local GK Dealer to locate your nearest GK Authorized Service Center. You may also call our Service Department at (408) 441-7970, ext.38 for reference to your nearest GK Authorized Service Center.

PROBLEMS:

PROBABLE CAUSES/SOLUTIONS:

LEDs light but no signal from Speaker Outputs, Headphones, or Line Outputs.	Be sure all tone controls and volumes are turned up at least part way.
LEDs light, tone and volumes turned up but no sound.	Check interconnections with speakers.
LEDs light, tone and volumes up, speakers and connections OK, but no signal from output.	Check guitar volume, pick-ups, cord, and repair or replace if necessary.
LEDs light, tone and volumes up, external speakers OK, guitar cord OK, guitar volume up and still no sound.	Call your Authorized GK Service Center.
Channel Switching or Lead Mode Select not functioning with footswitch plugged in and appropriate LED indicators "on".	Be sure front panel On/Off buttons are "In". Check footswitch cable.
Loud hum.	Check grounding of the unit and any effects going through the effects loop. Proper grounding is mandatory.
Excessive noise.	Repair or replace guitar cord. Make sure external effects are patched into the Send and Return and not before the Input. Test guitar pick-ups.
After playing for some time, the unit becomes hot to touch and shuts off - no LEDs lit or signal coming out.	Turn off power switch and allow unit to cool off. Turn on power again. If it comes on, make sure speaker load is no less than 4 ohms or that unit is not affected by another heat source (stage lighting, direct sunlight, etc.)
Amp is not hot to touch and still no power - no LEDs lit or signal coming out.	Check power cord, AC outlet and fuse. If all are OK or fuse is blown, call your local GK Authorized Service Center. NOTE: Be sure the correct fuse is being used.



Backline 100- Lead Amplifier

Turn-On Procedure

GK Document # 420-0093-C

Board #'s: 206-0093-C (pre amp), 206-0094-C (power amp)

Backline 100- all options 12/9/92 Rev. 11/23/99-SW

SETUP

- 1) Variac on zero, power switch off- connect power cord.
- 2) Connect output to load box with both sides connected together.
- 3) Resistance loads open (switch in center), speaker on.
- 4) 1X probe to scope-A.
- 5) Load box to scope-B and AC-VM.
- 6) Set oscillator on 200Hz sine wave @5mVrms (-26dBV).
- 7) DVM on 20mV range.
- 8) AC voltmeter on 30V range.
- 9) Scope-B on 10V/cm (or 5V uncalibrated).
- 10) Scope sweep on 1ms/cm, scope trigger on B.
- 11) Connect reverb wires from preamp - red to output of reverb.
- 12) On Backline Front Panel, set knobs to 0, switches out.

POWER SUPPLY ANY POWER AMP TEST

- 1) With power switch on, gradually increase variac to 50V. Listen to speaker and watch scope for no current draw.
- 2) Check preamp supplies- +/- 16VDC (+/- 1V margin).
- 3) Adjust variac to 120V and turn speaker off.
- 4) Set bias. Hook DVM across collectors of Q6 and Q81 and adjust R50 (on '94 board) for 2mV across power resistors (R11, 24,57,79).
- 5) Connect oscillator to return (200Hz @ -26dBV). Output = 9Vrms.
- 6) Increase oscillator to -6dBV (500mV).
- 7) Turn on 8 ohm load. Output = 16Vrms.
- 8) Turn load to 4 ohms. Output = 9Vrms.
- 9) Increase oscillator to +4dBV (500mV). Signal should clip at 22Vrms.
- 10) Turn on 2nd load to 4 ohms. Signal should round off and go to 13.5Vrms.

INPUT SET-UP AND LEAD CHANNEL TEST

- 1) Power LED only should be lit.
- 2) Engage channel switch (S4). Lead LED should turn on.
- 3) Oscillator to input (200Hz @ +4dBV). Engage lead 2 switch (S2).
- 4) Look at drain of Q10- adjust R6 so signal clips evenly on both sides- should be 22Vp-p centered 2.5V.
- 5) Adjust R91 (1k trim) for 7.5-8VDC on drain of Q86 (J113).
- 6) Adjust R104 (1k trim) for 7.5-8VDC on drain of Q96 (J113).
- 7) Increase gain to 10, watch signal become square wave at Q96- should clip evenly at 10Vp-p.
- 8) Decrease oscillator level to -66dBV (.5mV). Signal = 1.6Vrms (AC).
- 9) Set tones to 10, gain and volume to 12:00, switches out (lead in).
- 10) Set scope-B to 5V/cm and 1ms/cm.
- 11) Set oscillator to 200Hz square wave at -66dBV.
- 12) Look at output, compare to Fig. 1.
- 13) One at a time, turn tone knobs to 0 and compare to figures (resetting after finishing each): Bass to 0- Fig. 2; Mid to 0- Fig. 3; Treble to 0- Fig.4.
- 14) Engage Input Shape (S1), compare to Fig. 5. Disengage.
- 15) Engage Lead 2 (S2), compare to Fig. 6. Disengage.
- 16) Engage EQ Shift (S3), compare to Fig. 7. Disengage.

CLEAN CHANNEL, PRESENCE, VCV, AND REVERB TEST

- 1) Disengage Channel Select switch- change oscillator to -46dBV.
- 2) Look at output, compare to Fig. 8.
- 3) One at a time, turn tone knobs to 0 and compare outputs (resetting to 10 when done): Bass to 0- Fig.9; Mid to 0- Fig. 10; Treble to 0- Fig. 11.
- 4) Presence to 10- Fig. 12. Reset.
- 5) Engage EQ shift (S5), compare to Fig. 13. Disengage.
- 6) Engage VCV (S6), compare to Fig. 14. Disengage.

- 7) Reverb knob to 10- Fig. 15. Reset.
- 8) Scope to 50mV/div. Line out (J5) looks like Fig. 14 (different scale).
- 9) Scope to 5V/div. Headphone outs look like Fig. 8.

FOOTSWITCH TEST

- 1) With a stereo cord, connect RF2 to footswitch jack on front panel.
- 2) Engage Channel Switch and Lead 2 switch to the front panel.
- 3) If necessary, push footswitches so both LEDs are off.
- 4) Compare output to Fig. 8.
- 5) Engage Channel footswitch, LED on panel & footswitch light. Output goes up.
- 6) Engage Lead Channel footswitch, footswitch LED lights, output goes up.

NOISE TEST

- 1) Remove oscillator input.
- 2) Connect speaker to output and listen to noise. It should be clean with no distortion or crackling on both channels.

NOTES: UNLESS OTHERWISE SPECIFIED

1. VOLTAGES NOT IN BOXES ARE D.C.
- ARE RMS W/50V INPUT.
- ARE RMS W/50V INPUT.
- INPUT IS 100KZ.
- KNDS ON 10. SWITCHES OUT.
- C-CHANNEL SW OUT (CLEAN)
- L-CHANNEL SW IN (LEAD)

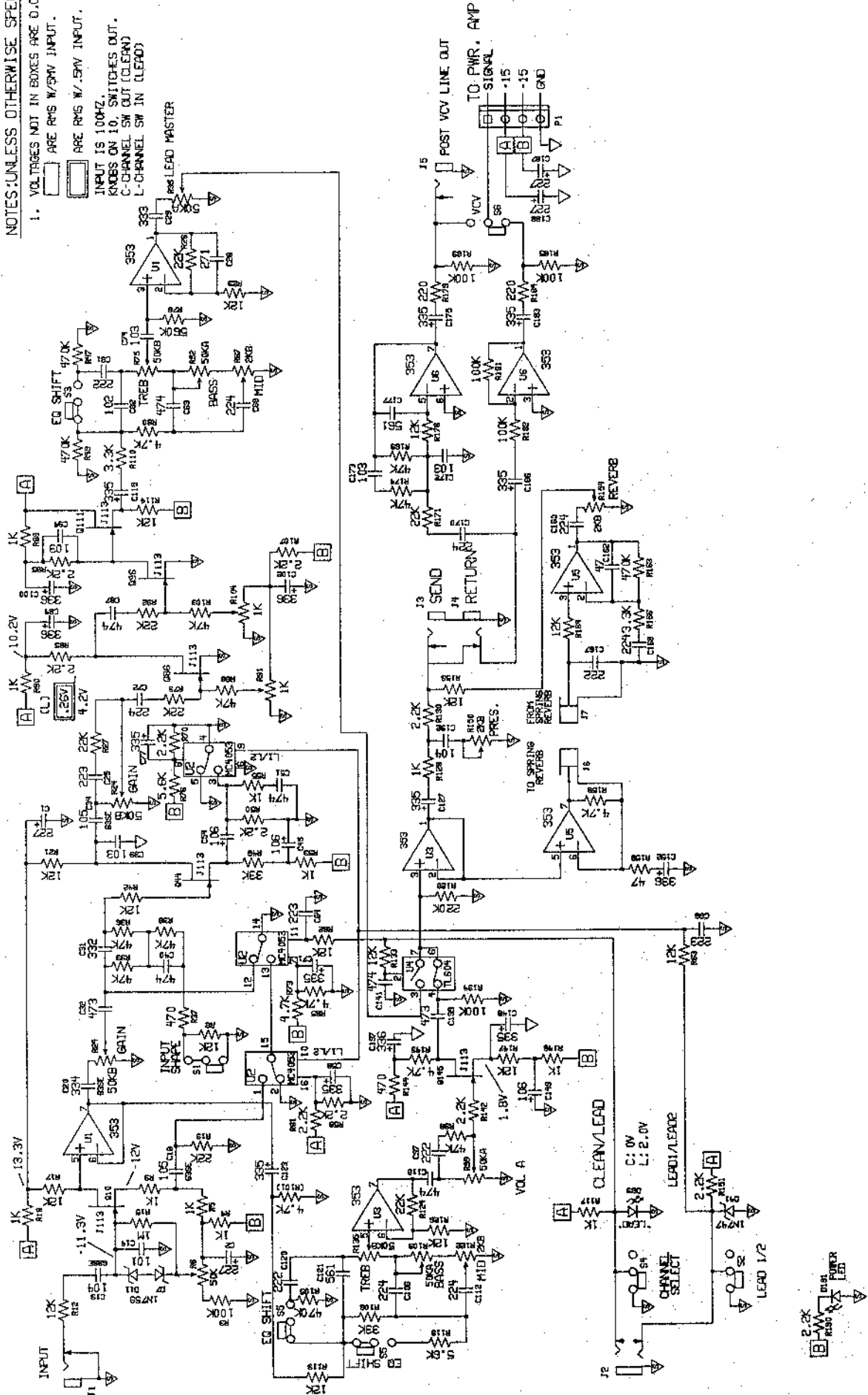

PCOM#	DATE	FIRST SN	PCOM#	DATE	FIRST SN	PCOM#	DATE	FIRST SN

PCOM#	DATE	FIRST SN	PCOM#	DATE	FIRST SN	PCOM#	DATE	FIRST SN

DESCRIPTION: BACKLINE 100 PREAMP
 DATE: 10/28/92
 MODEL #: BL 100
 DESIGNED BY: M.P.J.
 FROM SN: TO SN:
 PG: 1 OF 1
 DEF: 60093C
 406-0053-C

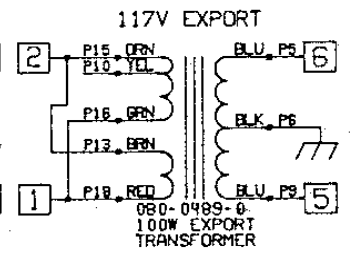
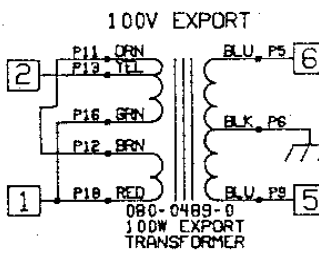
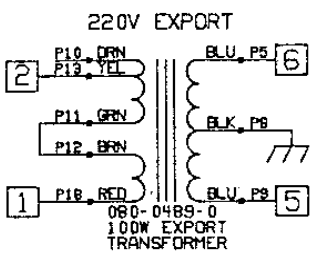
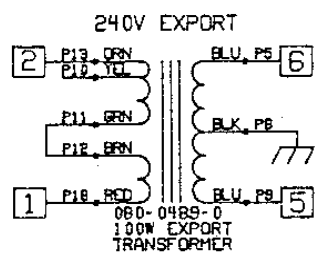
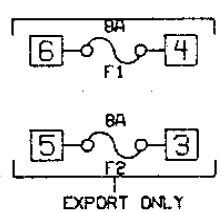
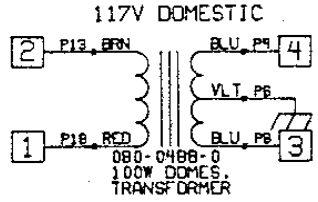
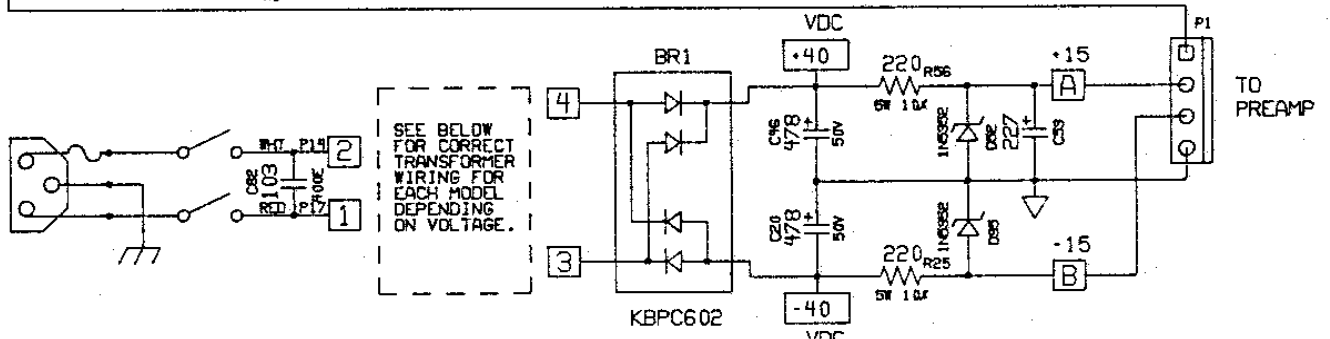
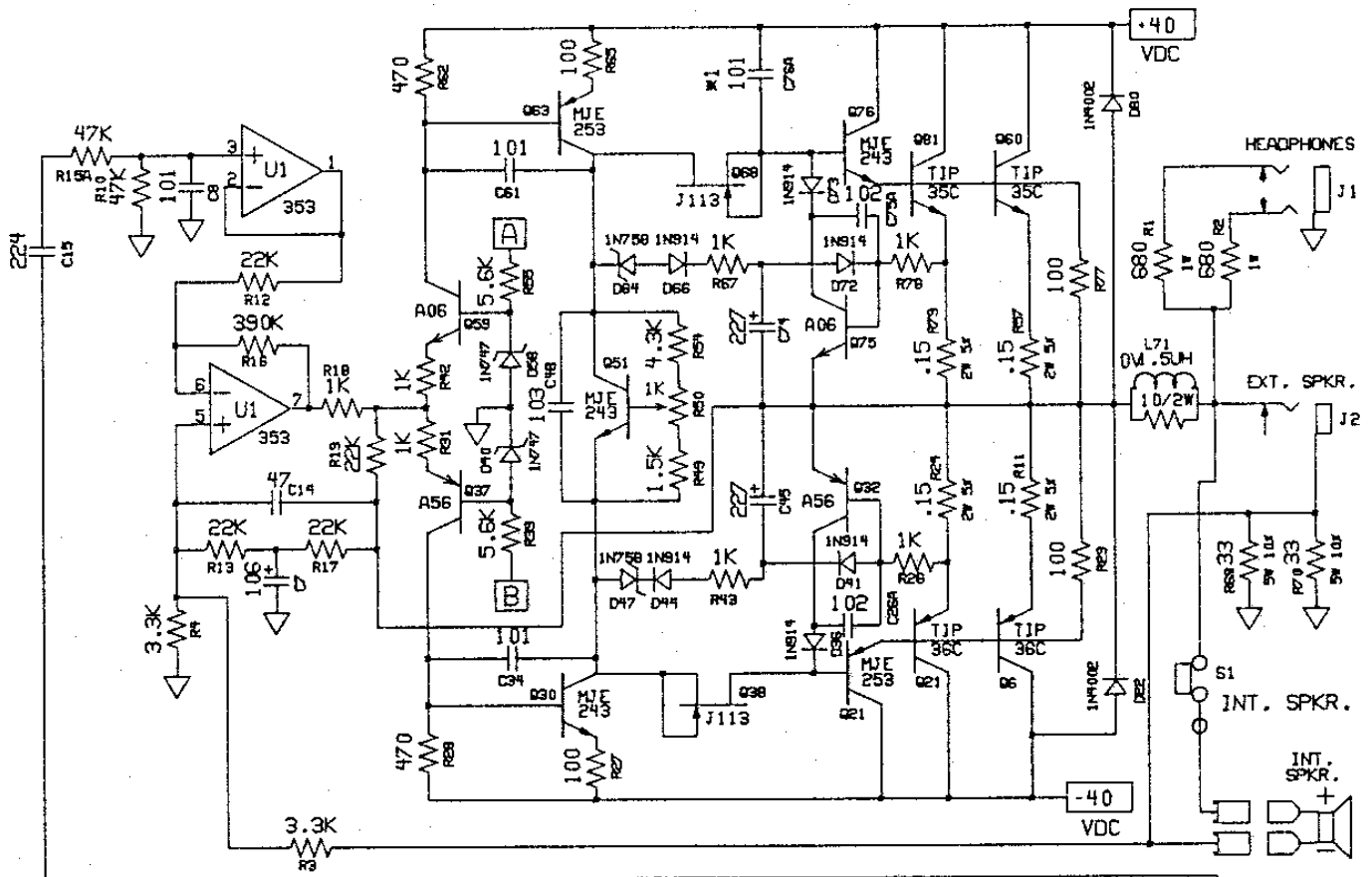

GK DOCUMENT #:	PCO#	DATE					
406-0094-C	1	11-92					
GALLIEN-KRUEGER		MODEL #:	DATE:	DESCRIPTION:			
		BL 100	12/3/92	BACK LINE 100 POWER AMP			
SCHMATIC	DBF:	DESIGNED BY:	PART #:	PCO#-DATE:	FROM SN:	TO SN:	
PG: 1 OF: 1	60094C	R.A.G.	406-0094-C	-			

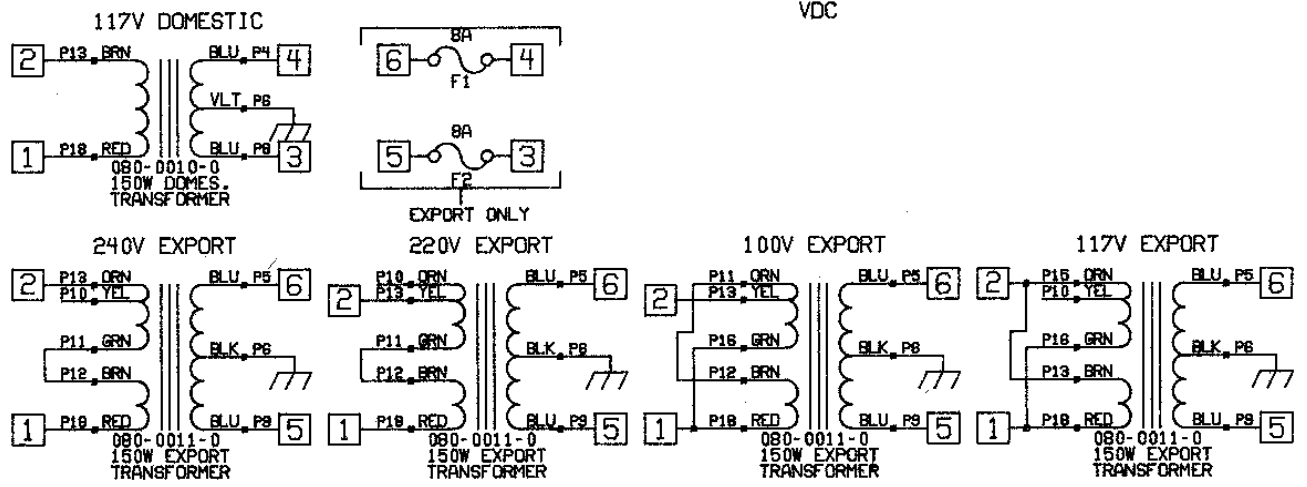
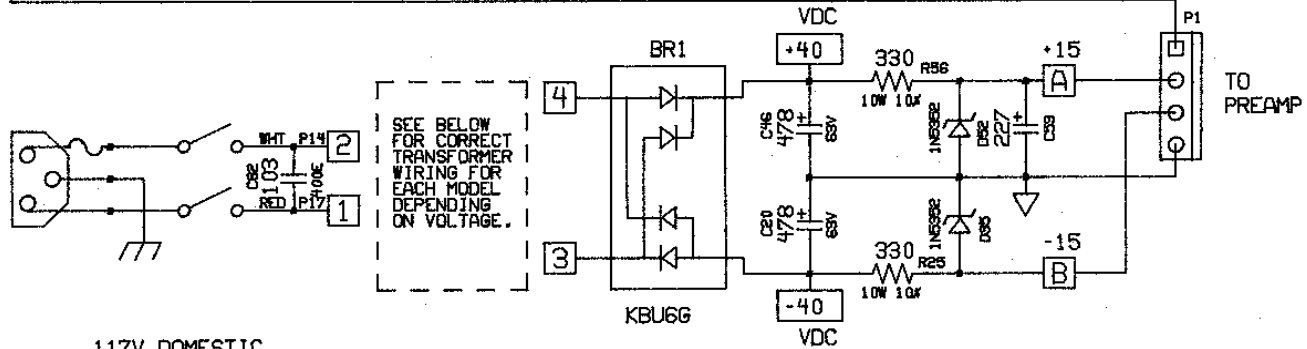
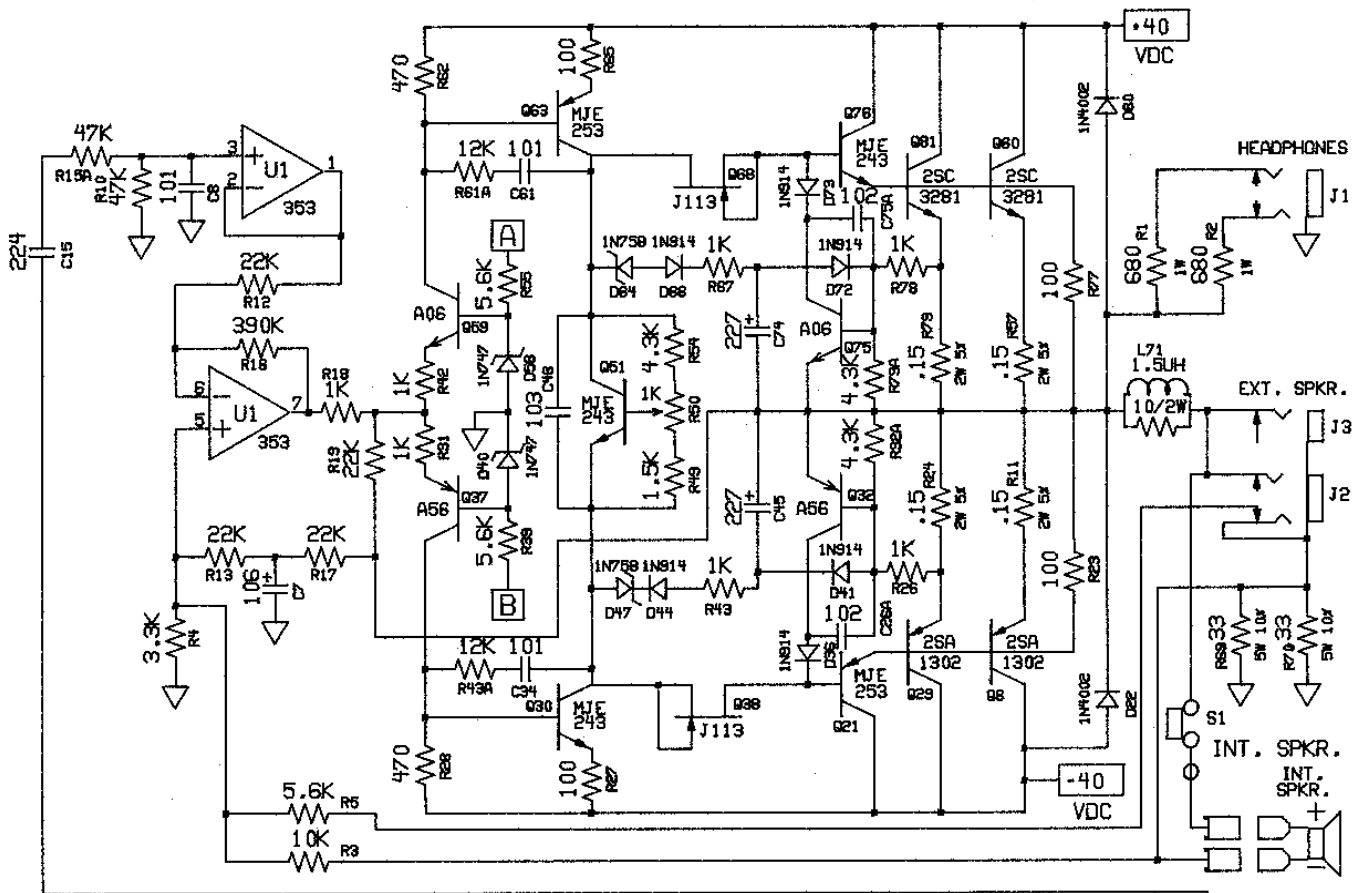

GK DOCUMENT #:	PCO#	DATE					
406-0095-D							
GALLIEN-KRUEGER 408-441-8081 2240 PARAGON, SAN JOSE, CA 95131		MODEL #:	DATE:	DESCRIPTION:			
		BL150	5/3/93	BACKLINE 150 POWER AMP			
SCHEMATIC		DBF:	DESIGNED BY:	PART #:	PCO#-DATE:		
PG: 1 OF: 1		60095D	RAG	406-0095-D			

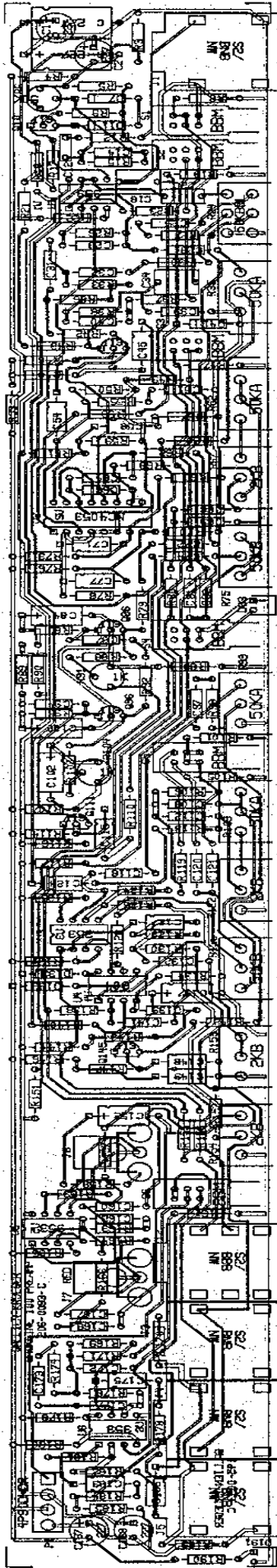

GALLIEN-KRUEGER
403-0093 REV C

COMPONENT SIDE SHOWN BOARD TREV0000

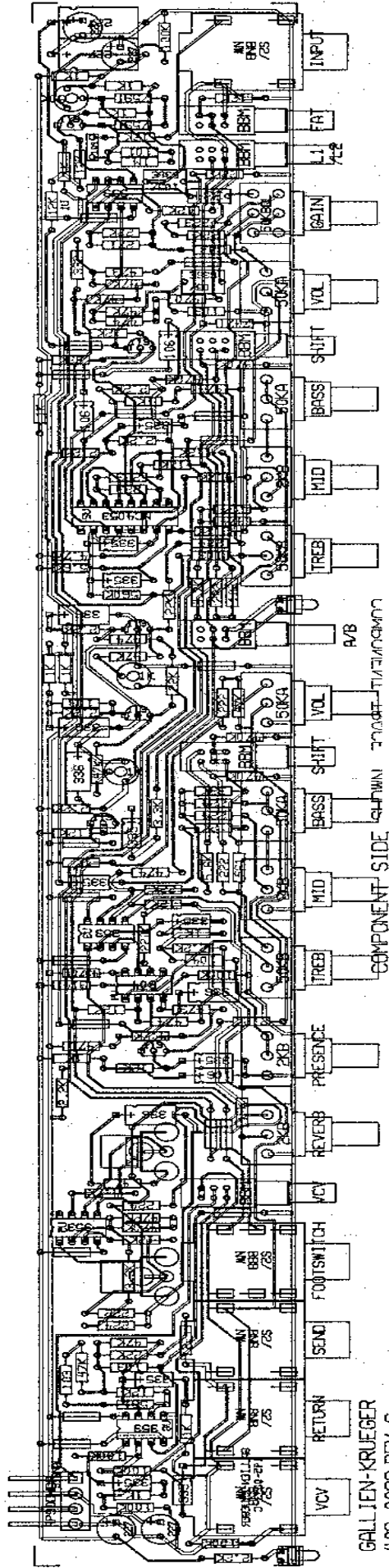

GALLIEN-KRUEGER
403-0093 REV C

COMPONENT SIDE SHOWN BOARD TREV0000

GALLIEN-KRUEGER		MODEL #:	DATE:	DESCRIPTION:
CIRCUIT BOARD DBF: 50093C		BL 100	9/2/92	BACKLINE 100 PREAMP BOARD
ARTWORK		DESIGNED BY: M.P.J.	REV#-DATE: 206-0093 C	FROM SN: TO SN:

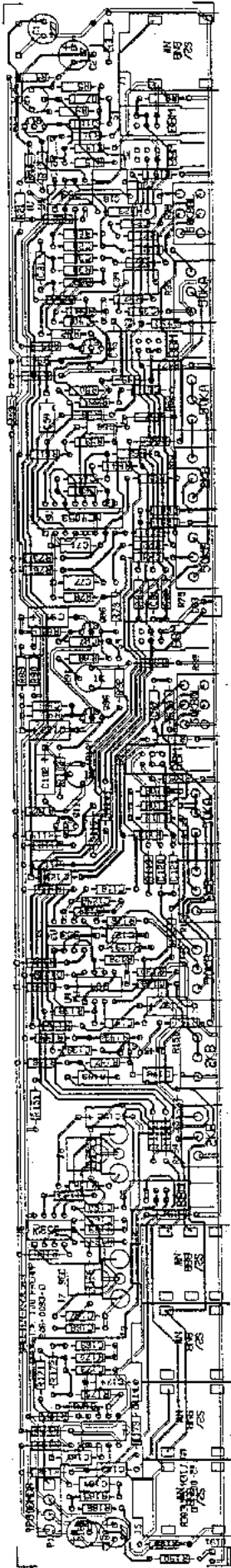

GALLIEN-KRUEGER
403-0093 REV D

COMPONENT SIDE SHOWN EARLY TIME/DATE

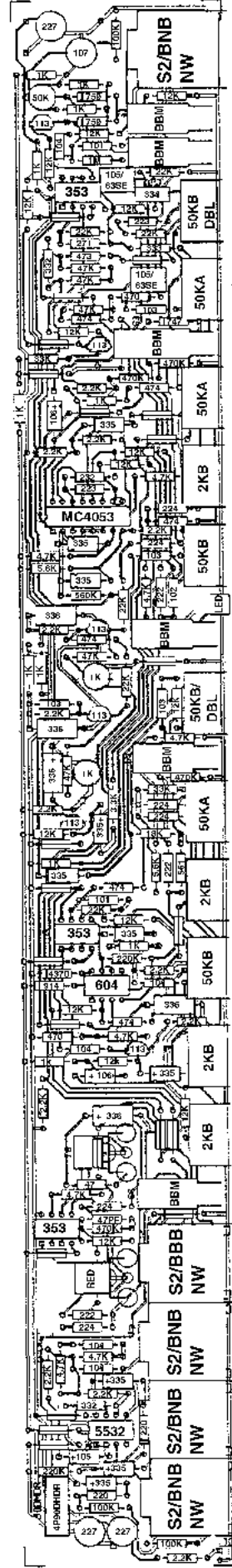

GALLIEN-KRUEGER
403-0093 REV D

COMPONENT SIDE SHOWN EARLY TIME/DATE

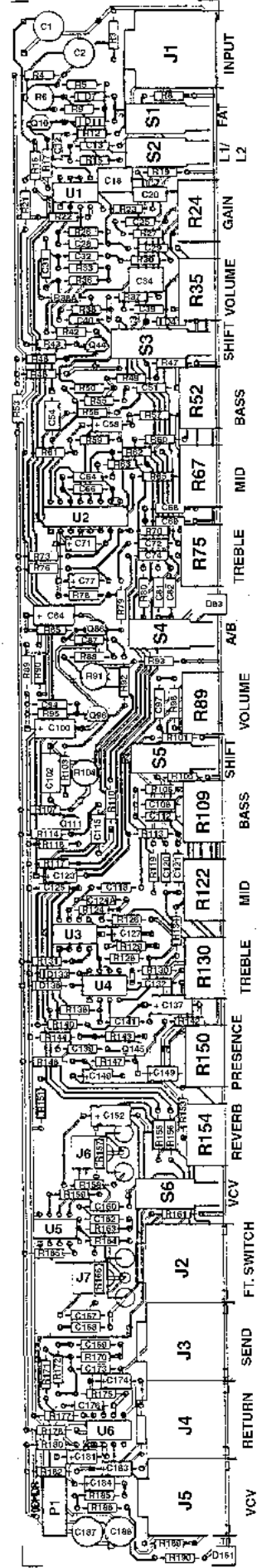

GALLIEN-KRUEGER
403-0093 REV D

COMPONENT SIDE SHOWN EARLY TIME/DATE

GALLIEN-KRUEGER CIRCUIT BOARD ARTWORK	MODEL #:	DATE:	DESCRIPTION:
	BL 100	11/27/52	BACKLINE 100 PREAMP BOARD
DESIGNED BY:	BOARD #:	REV#-DATE:	FROM SN:
M.P.J.	205-0093 D		TO SN:
50093D			

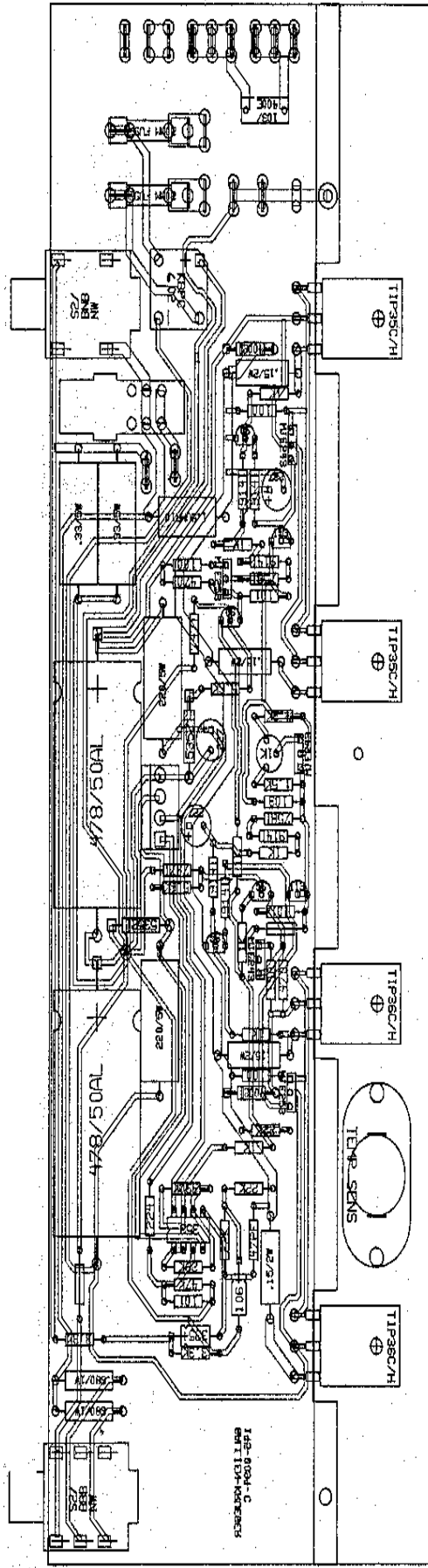
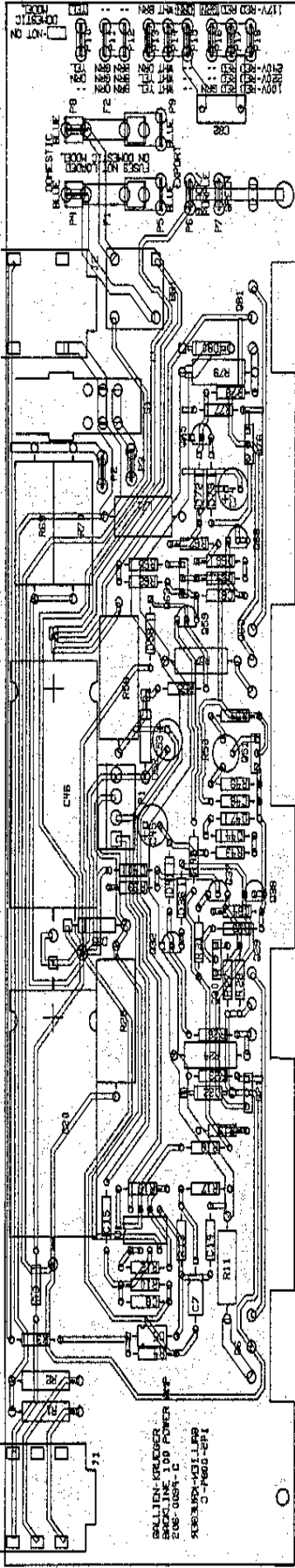

MODEL #:	BL 100	DATE:	8/31/92	DESCRIPTION:	BACKLINE 100 POWER AMP
DESIGNED BY:	R.A.G.	REV#-DATE:	206-0094 C	FROM SN:	TO SN:
CIRCUIT BOARD ARTWORK:	DBF: 50094C	BOARD #:			

403-0094 REV C
GALLIEN-KRUEGER

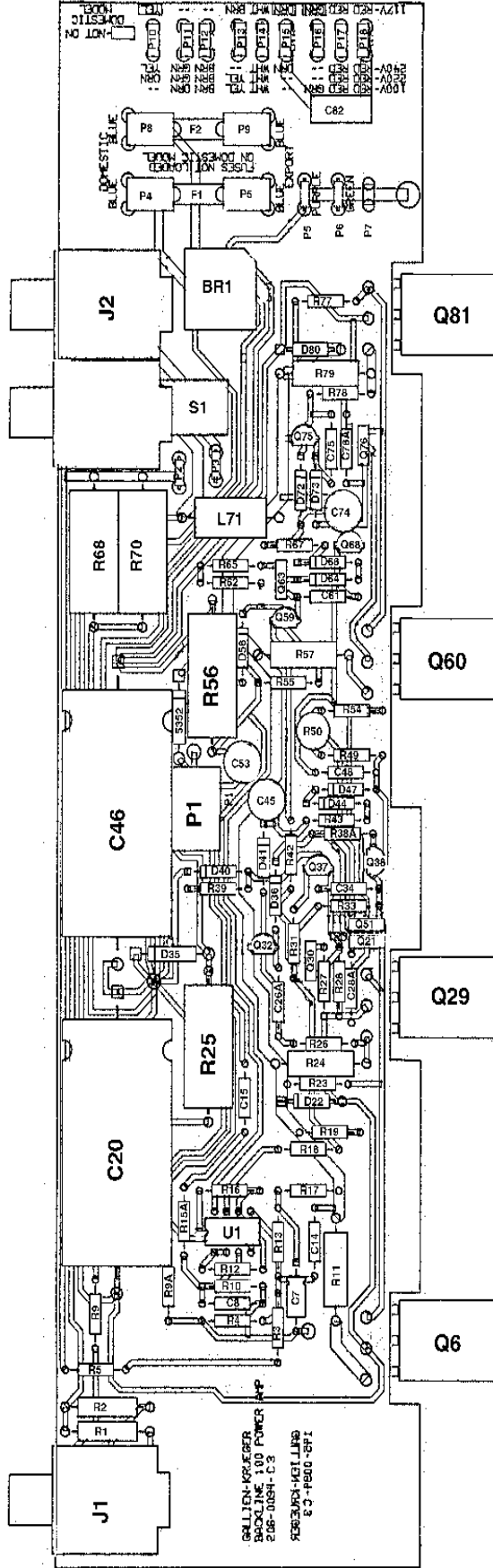
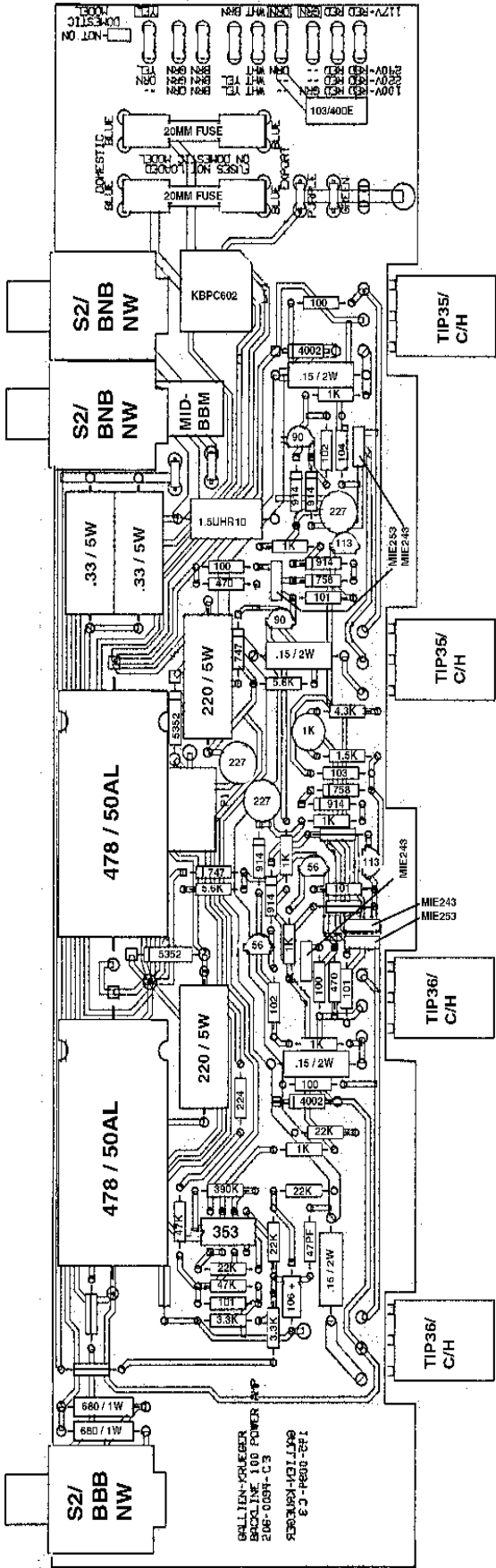

403-0094 REV C.3
 GALLIEN-KRUEGER

GALLIEN-KRUEGER	MODEL #:	DATE:	DESCRIPTION:
CIRCUIT BOARD	BL 100	12/3/92	BACKLINE 100 POWER AMP
ARTWORK	DESIGNED BY:	BOARD #:	REV#-DATE:
	R.A.G.	206-0094C3	FROM SN: TO SN:
	50094C3	3-12/3/92	

GALLIEN-KRUEGER PRODUCTION CHANGE ORDER PCO#: 1

DATE: 11-30-92 ASSEMBLY #: 406-0094C MODEL#: BACKLINE 100

ASSEMBLY DESCRIPTION: BACKLINE 100 POWER AMP PAGE ____ OF ____

AFFECTS OPTIONS: ALL 100V 120V 220V 240V 50HZ 60HZ

TYPE OF CHANGE:
 NECESSARY TO THE FUNCTION OF THE UNIT
 IMPROVEMENT OR ADDITION TO THE UNIT
 OTHER _____

CHANGE TO BE IMPLEMENTED TO: <input type="checkbox"/> NEXT PRODUCTION RUN <input checked="" type="checkbox"/> ALL UNITS IN PRODUCTION <input type="checkbox"/> ALL UNITS IN STOCK <input type="checkbox"/> ALL UNITS BEING SERVICED <input type="checkbox"/> OTHER _____	REMARKS: THIS CHANGE WAS INITIATED IN THE MIDDLE OF THE FIRST RUN OF 700 UNITS, SOME OF THEM OSC, AND THIS WAS THE FLY. ONLY ABOUT HALF OF THESE UNITS HAVE THIS MOD.
---	---

BEGINNING SERIAL NUMBER AFFECTED: _____

DESCRIPTION OF CHANGE: SEE PCO SUPPLEMENTS CONTINUED ON PCO SUPPLEMENT PAGE ____
 ADD 100PF CAP FROM BASE TO COLLECTOR OF Q76

REASON FOR CHANGE: ELIMINATE 5MHZ OSC IN TOP HALF WHEN DRIVING BJR NEAR FULL POWER.
~~5MHZ OSC.~~



PARTS ADDED				PARTS DELETED			
PART#	DESCRIPTION	QTY.	REF. DES.	PART#	DESCRIPTION	QTY.	REF. DES.
030-2101	100PF CER	1					

CONTINUED ON PAGE ____ CONTINUED ON PAGE ____

AFFECTED AREAS	DONE BY	DATE	AFFECTED AREAS (CONT)	DONE BY	DATE
<input checked="" type="checkbox"/> CIRCUIT SCHEMATIC	RAG	11-30-92	<input type="checkbox"/>		
<input checked="" type="checkbox"/> BILL OF MATERIAL	RAG	11-30-92	<input type="checkbox"/>		
<input type="checkbox"/> AUTO INSERTER			<input type="checkbox"/>		
<input checked="" type="checkbox"/> SAMPLE CHANGE	RAG	11-27-92	DOCUMENT DIST. LIST	# COPIES	
<input type="checkbox"/> TEST PROCEDURE			<input type="checkbox"/> GK USA		
<input type="checkbox"/> COMP. CONTROL FORM			<input type="checkbox"/> SERVICE CENTERS		
<input type="checkbox"/> FAB DRAWING			<input type="checkbox"/> GK EUROPE		
<input type="checkbox"/> PUNCH PROGRAM			<input type="checkbox"/> GK CAMPBELL		
<input type="checkbox"/> PUNCH SAMPLE			<input type="checkbox"/> ENGINEERING		
<input type="checkbox"/> ASSEMBLY PROCEDURES			<input type="checkbox"/> FABRICATION		
<input type="checkbox"/> ARTWORK			<input type="checkbox"/> PRODUCTION		
<input type="checkbox"/> SILKSCREEN TEMPLATE			<input type="checkbox"/> OUTSIDE SUPPLIERS		
<input type="checkbox"/>			<input type="checkbox"/>		

DRAWING(S) SHOWING MODIFICATION ATTACHED: NO YES - SPECIFY: _____

WRITTEN BY: RAG DEPT: _____ DATE: _____
 REVIEWED/APPROVED BY: RAG DEPT: _____ DATE: 11-30-92

GALLIEN-KRUEGER		PRODUCTION CHANGE ORDER		PCO#: 2			
DATE: 12/2/92		ASSEMBLY #: 145-0093 C (to D)		MODEL#: Backline 100			
ASSEMBLY DESCRIPTION: Backline Preamplifier Board				PAGE 1 OF 1			
AFFECTS OPTIONS: <input checked="" type="checkbox"/> ALL <input type="checkbox"/> 100V <input type="checkbox"/> 120V <input type="checkbox"/> 220V <input type="checkbox"/> 240V <input type="checkbox"/> 50HZ <input type="checkbox"/> 60HZ							
TYPE OF CHANGE: <input type="checkbox"/> NECESSARY TO THE FUNCTION OF THE UNIT <input checked="" type="checkbox"/> IMPROVEMENT OR ADDITION TO THE UNIT <input type="checkbox"/> OTHER _____							
CHANGE TO BE IMPLEMENTED TO: <input checked="" type="checkbox"/> NEXT PRODUCTION RUN <input type="checkbox"/> ALL UNITS IN PRODUCTION <input type="checkbox"/> ALL UNITS IN STOCK <input type="checkbox"/> ALL UNITS BEING SERVICED <input type="checkbox"/> OTHER _____			REMARKS:				
BEGINNING SERIAL NUMBER AFFECTED:							
DESCRIPTION OF CHANGE: <input type="checkbox"/> SEE PCO SUPPLEMENTS <input type="checkbox"/> CONTINUED ON PCO SUPPLEMENT PAGE _____ Change board rev. from C to D							
REASON FOR CHANGE: Incorporate changes done to board that currently are being done by hand							
PARTS ADDED				PARTS DELETED			
PART#	DESCRIPTION	QTY.	REF. DES.	PART#	DESCRIPTION	QTY.	REF. DES.
<input type="checkbox"/> CONTINUED ON PAGE _____				<input type="checkbox"/> CONTINUED ON PAGE _____			
AFFECTED AREAS		DONE BY	DATE	AFFECTED AREAS (CONT)		DONE BY	DATE
<input type="checkbox"/> CIRCUIT SCHEMATIC				<input type="checkbox"/>			
<input checked="" type="checkbox"/> BILL OF MATERIAL				<input type="checkbox"/>			
<input checked="" type="checkbox"/> AUTO INSERTER				<input type="checkbox"/>			
<input checked="" type="checkbox"/> SAMPLE CHANGE				DOCUMENT DIST. LIST		# COPIES	
<input type="checkbox"/> TEST PROCEDURE				<input type="checkbox"/> GK USA			
<input type="checkbox"/> COMP. CONTROL FORM				<input type="checkbox"/> SERVICE CENTERS			
<input type="checkbox"/> FAB DRAWING				<input type="checkbox"/> GK EUROPE			
<input type="checkbox"/> PUNCH PROGRAM				<input type="checkbox"/> GK CAMPBELL			
<input type="checkbox"/> PUNCH SAMPLE				<input type="checkbox"/> ENGINEERING			
<input type="checkbox"/> ASSEMBLY PROCEDURES				<input type="checkbox"/> FABRICATION			
<input checked="" type="checkbox"/> ARTWORK		mg	12-2-92	<input checked="" type="checkbox"/> PRODUCTION			
<input type="checkbox"/> SILKSCREEN TEMPLATE				<input type="checkbox"/> OUTSIDE SUPPLIERS			
<input type="checkbox"/>				<input type="checkbox"/>			
DRAWING(S) SHOWING MODIFICATION ATTACHED: <input checked="" type="checkbox"/> NO <input type="checkbox"/> YES - SPECIFY:							
WRITTEN BY: Michael Johns				DEPT: Eng		DATE: 12-2-92	
REVIEWED/APPROVED BY: [Signature]				DEPT: "		DATE:	

Goes with Backline 100
PCO's 2 & 3

assy notes:

0094 1) when loading Q21 and Q51, the top face the direction where the value is written on the board.

0094 2) Apply thermal grease to one of these parts then insert them in the board and screw them together with a #4 nut & bolt. This is done before wave soldering.

0094 3) Bend leads of 220r/5w resistors to stand them up off the board:

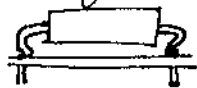

something like this

0093 4) Change C97 from 472 to 103 and R98 from 22K to 12K

2094 5) Don't need to load wire on power amp.

0093 6) Mill out board for LED (DB3) (PCO#7)

GALLIEN-KRUEGER		PRODUCTION CHANGE ORDER		PCO#: 3			
DATE: 12/4/92		ASSEMBLY #: 145-0094C (to C3)		MODEL#: BackLine 100			
ASSEMBLY DESCRIPTION: BackLine Power Amp/Supply Board				PAGE 1 OF 1			
AFFECTS OPTIONS: <input checked="" type="checkbox"/> ALL <input type="checkbox"/> 100V <input type="checkbox"/> 120V <input type="checkbox"/> 220V <input type="checkbox"/> 240V <input type="checkbox"/> 50HZ <input type="checkbox"/> 60HZ							
TYPE OF CHANGE: <input type="checkbox"/> NECESSARY TO THE FUNCTION OF THE UNIT <input checked="" type="checkbox"/> IMPROVEMENT OR ADDITION TO THE UNIT <input type="checkbox"/> OTHER _____							
CHANGE TO BE IMPLEMENTED TO: <input checked="" type="checkbox"/> NEXT PRODUCTION RUN <input type="checkbox"/> ALL UNITS IN PRODUCTION <input type="checkbox"/> ALL UNITS IN STOCK <input type="checkbox"/> ALL UNITS BEING SERVICED <input type="checkbox"/> OTHER _____			REMARKS: This is a temporary fix to allow less hand-done modification while we work on fixing some of the problems.				
BEGINNING SERIAL NUMBER AFFECTED:							
DESCRIPTION OF CHANGE: <input type="checkbox"/> SEE PCO SUPPLEMENTS <input type="checkbox"/> CONTINUED ON PCO SUPPLEMENT PAGE _____							
change board from C rev. to C3							
REASON FOR CHANGE: Incorporate changes currently being done by hand.							
PARTS ADDED				PARTS DELETED			
PART#	DESCRIPTION	QTY.	REF. DES.	PART#	DESCRIPTION	QTY.	REF. DES.
<input type="checkbox"/> CONTINUED ON PAGE _____				<input type="checkbox"/> CONTINUED ON PAGE _____			
AFFECTED AREAS		DONE BY	DATE	AFFECTED AREAS (CONT)		DONE BY	DATE
<input type="checkbox"/> CIRCUIT SCHEMATIC				<input type="checkbox"/>			
<input checked="" type="checkbox"/> BILL OF MATERIAL				<input type="checkbox"/>			
<input checked="" type="checkbox"/> AUTO INSERTER				<input type="checkbox"/>			
<input checked="" type="checkbox"/> SAMPLE CHANGE				DOCUMENT DIST. LIST		# COPIES	
<input type="checkbox"/> TEST PROCEDURE				<input type="checkbox"/> GK USA			
<input type="checkbox"/> COMP. CONTROL FORM				<input type="checkbox"/> SERVICE CENTERS			
<input type="checkbox"/> FAB DRAWING				<input type="checkbox"/> GK EUROPE			
<input type="checkbox"/> PUNCH PROGRAM				<input type="checkbox"/> GK CAMPBELL			
<input type="checkbox"/> PUNCH SAMPLE				<input type="checkbox"/> ENGINEERING			
<input type="checkbox"/> ASSEMBLY PROCEDURES				<input type="checkbox"/> FABRICATION			
<input checked="" type="checkbox"/> ARTWORK		MG	12-4-92	<input checked="" type="checkbox"/> PRODUCTION			
<input type="checkbox"/> SILKSCREEN TEMPLATE				<input type="checkbox"/> OUTSIDE SUPPLIERS			
<input type="checkbox"/>				<input type="checkbox"/>			
DRAWING(S) SHOWING MODIFICATION ATTACHED: <input type="checkbox"/> NO <input type="checkbox"/> YES-SPECIFY:							
WRITTEN BY: <i>Metal Shop</i>				DEPT: <i>Eng</i>		DATE: <i>12-4-92</i>	
REVIEWED/APPROVED BY: <i>[Signature]</i>				DEPT: <i>[Signature]</i>		DATE: <i>[Signature]</i>	

GALLIEN-KRUEGER PRODUCTION CHANGE ORDER PCO#: 8

DATE: 2/25/93 ASSEMBLY #: MODEL#: Backline 100
 ASSEMBLY DESCRIPTION: Backline Chassis and main Assy. PAGE 1 OF 1

AFFECTS OPTIONS: ALL 100V 120V 220V 240V 50HZ 60HZ

TYPE OF CHANGE:
 NECESSARY TO THE FUNCTION OF THE UNIT
 IMPROVEMENT OR ADDITION TO THE UNIT
 OTHER: *Req. for CSA approval*

CHANGE TO BE IMPLEMENTED TO:
 NEXT PRODUCTION RUN
 ALL UNITS IN PRODUCTION
 ALL UNITS IN STOCK
 ALL UNITS BEING SERVICED
 OTHER _____

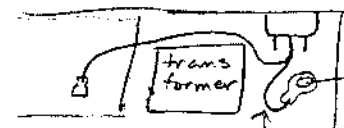
REMARKS:
 #6 screw with solder lug
 add this green wire

BEGINNING SERIAL NUMBER AFFECTED:

DESCRIPTION OF CHANGE: SEE PCO SUPPLEMENTS CONTINUED ON PCO SUPPLEMENT PAGE _____

- 1.) The chassis will have an extra #6 hole punched in it near the transformer.
- 2.) A solder lug will then be screwed into this hole.
- 3.) A wire (use green) will be wired from the solder lug to the center terminal of the AC receptical (where the other green wire goes)

REASON FOR CHANGE:
 1) To pass Canada's CSA approval

PARTS ADDED				PARTS DELETED			
PART#	DESCRIPTION	QTY.	REF. DES.	PART#	DESCRIPTION	QTY.	REF. DES.
	#6 top-to-bottom screw	1					
	#6 1/2" #4 solder lug	1					
	4" to 5" green wire	1					

CONTINUED ON PAGE _____ CONTINUED ON PAGE _____

AFFECTED AREAS	DONE BY	DATE	AFFECTED AREAS (CONT)	DONE BY	DATE
<input type="checkbox"/> CIRCUIT SCHEMATIC			<input type="checkbox"/>		
<input checked="" type="checkbox"/> BILL OF MATERIAL			<input type="checkbox"/>		
<input type="checkbox"/> AUTO INSERTER			<input type="checkbox"/>		
<input checked="" type="checkbox"/> SAMPLE CHANGE			DOCUMENT DIST. LIST	# COPIES	
<input type="checkbox"/> TEST PROCEDURE			<input type="checkbox"/> GK USA		
<input type="checkbox"/> COMP. CONTROL FORM			<input type="checkbox"/> SERVICE CENTERS		
<input type="checkbox"/> FAB DRAWING			<input type="checkbox"/> GK EUROPE		
<input checked="" type="checkbox"/> PUNCH PROGRAM			<input type="checkbox"/> GK CAMPBELL		
<input checked="" type="checkbox"/> PUNCH SAMPLE			<input type="checkbox"/> ENGINEERING		
<input checked="" type="checkbox"/> ASSEMBLY PROCEDURES			<input type="checkbox"/> FABRICATION		
<input type="checkbox"/> ARTWORK			<input type="checkbox"/> PRODUCTION		
<input type="checkbox"/> SILKSCREEN TEMPLATE			<input type="checkbox"/> OUTSIDE SUPPLIERS		
<input type="checkbox"/>			<input type="checkbox"/>		

DRAWING(S) SHOWING MODIFICATION ATTACHED: NO YES - SPECIFY:

WRITTEN BY: *Michael Jones* DEPT: *Eng* DATE: 2/25/93
 REVIEWED/APPROVED BY: DEPT: DATE:

GALLIEN-KRUEGER PRODUCTION CHANGE ORDER PCO#: 9

DATE: 4/2/93 ASSEMBLY #: 206-0093-D MODEL#: BackLine100

ASSEMBLY DESCRIPTION: BackLine Preamp PAGE 1 OF 1

AFFECTS OPTIONS: ALL 100V 120V 220V 240V 50HZ 60HZ

TYPE OF CHANGE:
 NECESSARY TO THE FUNCTION OF THE UNIT
 IMPROVEMENT OR ADDITION TO THE UNIT
 OTHER _____

CHANGE TO BE IMPLEMENTED TO: <input checked="" type="checkbox"/> NEXT PRODUCTION RUN <input type="checkbox"/> ALL UNITS IN PRODUCTION <input type="checkbox"/> ALL UNITS IN STOCK <input type="checkbox"/> ALL UNITS BEING SERVICED <input type="checkbox"/> OTHER _____	REMARKS:
---	----------

BEGINNING SERIAL NUMBER AFFECTED:

DESCRIPTION OF CHANGE: SEE PCO SUPPLEMENTS CONTINUED ON PCO SUPPLEMENT PAGE _____

1. Change R17 and R21 from 12K 5% res. to 12.1K 1% metal film resistors
 2. Change R46 from 33K 5% res. to 33K 1% metal film resistor.

REASON FOR CHANGE:
 Should result in less noise problems due to noisy resistors in the FET gain stages

PARTS ADDED				PARTS DELETED			
PART#	DESCRIPTION	QTY.	REF. DES.	PART#	DESCRIPTION	QTY.	REF. DES.
	12K 1% metal film	2	R17, R21		12K 5%	2	R17, R21
	33K 1% metal film	1	R46		33K 5%	1	R46

CONTINUED ON PAGE _____ CONTINUED ON PAGE _____

AFFECTED AREAS	DONE BY	DATE	AFFECTED AREAS (CONT)	DONE BY	DATE
<input checked="" type="checkbox"/> CIRCUIT SCHEMATIC			<input type="checkbox"/>		
<input checked="" type="checkbox"/> BILL OF MATERIAL			<input type="checkbox"/>		
<input checked="" type="checkbox"/> AUTO INSERTER			<input type="checkbox"/>		
<input checked="" type="checkbox"/> SAMPLE CHANGE			DOCUMENT DIST. LIST	# COPIES	
<input type="checkbox"/> TEST PROCEDURE			<input type="checkbox"/> GK USA		
<input type="checkbox"/> COMP. CONTROL FORM			<input type="checkbox"/> SERVICE CENTERS		
<input type="checkbox"/> FAB DRAWING			<input type="checkbox"/> GK EUROPE		
<input type="checkbox"/> PUNCH PROGRAM			<input type="checkbox"/> GK CAMPBELL		
<input type="checkbox"/> PUNCH SAMPLE			<input type="checkbox"/> ENGINEERING		
<input type="checkbox"/> ASSEMBLY PROCEDURES			<input type="checkbox"/> FABRICATION		
<input type="checkbox"/> ARTWORK			<input type="checkbox"/> PRODUCTION		
<input type="checkbox"/> SILKSCREEN TEMPLATE			<input type="checkbox"/> OUTSIDE SUPPLIERS		
<input type="checkbox"/>			<input type="checkbox"/>		

DRAWING(S) SHOWING MODIFICATION ATTACHED: NO YES - SPECIFY:

WRITTEN BY: Michael Davis DEPT: Eng DATE: 4/2/93
 REVIEWED/APPROVED BY: DATE:

GALLIEN-KRUEGER		PRODUCTION CHANGE ORDER		PCO#: 10			
DATE: 4/6/93		ASSEMBLY #:		MODEL#: Backline 100			
ASSEMBLY DESCRIPTION: Backline Main Assy.				PAGE 1 OF 1			
AFFECTS OPTIONS: <input checked="" type="checkbox"/> ALL <input type="checkbox"/> 100V <input type="checkbox"/> 120V <input type="checkbox"/> 220V <input type="checkbox"/> 240V <input type="checkbox"/> 50HZ <input type="checkbox"/> 60HZ							
TYPE OF CHANGE: <input type="checkbox"/> NECESSARY TO THE FUNCTION OF THE UNIT <input type="checkbox"/> IMPROVEMENT OR ADDITION TO THE UNIT <input checked="" type="checkbox"/> OTHER <i>Modification to PCO# 8</i>							
CHANGE TO BE IMPLEMENTED TO: <input checked="" type="checkbox"/> NEXT PRODUCTION RUN <input type="checkbox"/> ALL UNITS IN PRODUCTION <input type="checkbox"/> ALL UNITS IN STOCK <input type="checkbox"/> ALL UNITS BEING SERVICED <input type="checkbox"/> OTHER _____			REMARKS:				
BEGINNING SERIAL NUMBER AFFECTED:							
DESCRIPTION OF CHANGE: <input type="checkbox"/> SEE PCO SUPPLEMENTS <input type="checkbox"/> CONTINUED ON PCO SUPPLEMENT PAGE _____ <i>1. a #4 nut and bolt must be used to hold the solder lug into place instead of a #6 thread rolling screw.</i>							
REASON FOR CHANGE: <i>1. CSA approval requirements</i>							
PARTS ADDED			PARTS DELETED				
PART#	DESCRIPTION	QTY.	REF. DES.	PART#	DESCRIPTION	QTY.	REF. DES.
	4-40 screw	1			6-32 thread rolling screw	1	
	4-40 nut	1					
<input type="checkbox"/> CONTINUED ON PAGE _____			<input type="checkbox"/> CONTINUED ON PAGE _____				
AFFECTED AREAS	DONE BY	DATE	AFFECTED AREAS (CONT)	DONE BY	DATE		
<input type="checkbox"/> CIRCUIT SCHEMATIC			<input type="checkbox"/>				
<input checked="" type="checkbox"/> BILL OF MATERIAL			<input type="checkbox"/>				
<input type="checkbox"/> AUTO INSERTER			<input type="checkbox"/>				
<input checked="" type="checkbox"/> SAMPLE CHANGE			DOCUMENT DIST. LIST	# COPIES			
<input type="checkbox"/> TEST PROCEDURE			<input type="checkbox"/> GK USA				
<input type="checkbox"/> COMP. CONTROL FORM			<input type="checkbox"/> SERVICE CENTERS				
<input type="checkbox"/> FAB DRAWING			<input type="checkbox"/> GK EUROPE				
<input type="checkbox"/> PUNCH PROGRAM			<input type="checkbox"/> GK CAMPBELL				
<input type="checkbox"/> PUNCH SAMPLE			<input type="checkbox"/> ENGINEERING				
<input checked="" type="checkbox"/> ASSEMBLY PROCEDURES			<input type="checkbox"/> FABRICATION				
<input type="checkbox"/> ARTWORK			<input type="checkbox"/> PRODUCTION				
<input type="checkbox"/> SILKSCREEN TEMPLATE			<input type="checkbox"/> OUTSIDE SUPPLIERS				
<input type="checkbox"/>			<input type="checkbox"/>				
DRAWING(S) SHOWING MODIFICATION ATTACHED: <input checked="" type="checkbox"/> NO <input type="checkbox"/> YES-SPECIFY:							
WRITTEN BY: <i>Michael Johnson</i>		DEPT: <i>Eng</i>		DATE: 4/6/93			
REVIEWED/APPROVED BY:		DEPT:		DATE:			

BACKLINE 100 INDENTED BILL OF MATERIALS

11/24/99-SW

NOTE:

Level 1 refers to main assembly/ combo parts.
 Level 2 refers to board level components.
 Main assembly numbers are in bold face, while
 commonly needed parts are italicized.

LVL	PART#	DESCRIPTION	QTY	REF. DESIG.
1	<i>082-0003-0</i>	<i>SPEAKER, 12",100W,Z=8,EMINENCE</i>	1	
1	082-0004-0	REVERB, BACKLINE	1	
1	092-0064-0	Q-CON, .25 TAB,18-22GA,INSULATED	2	
1	092-0065-0	Q-CON, .187 TAB, INSULATED	2	
1	<i>095-0005-0</i>	<i>POWER CORD,117V PLUG,DETACH</i>	1	
1	100-0041-0	WIRE HOLDER N-4	2	
1	<i>100-0080-0</i>	<i>HANDLE RUBBER,10"</i>	1	
1	100-0081-0	CORNER,CHEVRON,PLASTIC,WOOD CABS	6	
1	112-4060-0	SCREW 6AB 3/8 FHP 82' B.O.	1	
1	114-2200-0	BOLT 10-32 1 1/4 OHP B.O.	10	
1	114-5120-0	SHEETMETAL SCREW 10A 3/4 OHP B.O.	28	
1	114-7008-0	WASHER #10 COUNTERSUNK FINISHING B.O.	4	
1	130-0071-0	PARAGON VL100 OVERLAY	1	
1	132-0577-0	BACKLINE GRILL	1	
1	133-0004-0	TOLEX BLACK	0	
1	205-1013-0	CABINET,BACKLINE	1	
1	250-0015-0	CHASSIS,BACKLINE/EMIN	1	
2	011-0243-0	MJE243 NPN 100V 4A TO-126	1	
2	<i>012-0085-0</i>	<i>TIP-35CFP NPN 100V 25A TO218</i>	2	
2	<i>012-1086-0</i>	<i>TIP 36CFP,PNP,100V,25A,TO-218,PECOR</i>	2	
2	<i>080-0488-0</i>	<i>X-FORMER BACKLINE,DOMESTIC-120V</i>	1	
2	<i>080-0489-0</i>	<i>X-FORMER BACKLINE,EXPORT-240V</i>	1	
2	<i>090-0020-0</i>	<i>SWITCH,ROCKER.DPST,4A,QUICK CONNECT</i>	1	
2	091-0011-0	FUSE, 2A,125V,5MM X 20MM	2	
2	091-0024-0	FUSE, 4A,240V,5MM X 20MM,SLB	1	
2	091-0028-0	FUSE, 8A,240V,5MM X 20MM,SLB	1	
2	092-0064-0	Q-CON, .25 TAB,18-22GA,INSULATED	13	
2	092-0065-0	Q-CON, .187 TAB, INSULATED	4	
2	<i>093-0012-0</i>	<i>RECEPTICAL AC/FUSE HOLDER,QUICK CON,-C 1</i>		

LVL	PART#	DESCRIPTION	QTY	REF. DESIG.
2	093-0013-0	FUSE HOLDER FOR A/C RECEPTICAL	1	
2	093-0035-0	HOUSING,4X.156,FEMALE 22GA,LOCK	2	
2	094-0018-0	SOLDER LUG,#4	1	
2	095-0100-0	WIRE, 22GA,BLACK,19 STRAND	1	
2	095-0102-0	WIRE,22GA,RED,19 STRAND	1	
2	095-0105-0	WIRE,22GA,GREEN,19 STRAND	1	
2	095-0106-0	WIRE,22GA,BLUE,19 STRAND	1	
2	095-0302-0	WIRE,18GA,RED,600V	1	
2	095-0305-0	WIRE,18GA,GREEN,600V	0	
2	095-0309-0	WIRE,18GA,WHITE,600V	1	
2	100-0012-0	GROMIT,3/16 X.100	1	
2	100-0013-0	STRAIN RELIEF,6P4	1	
2	100-0018-0	WIRE SADDLE ADH. BASE	2	
2	100-0028-0	BUTTON,SQUARE BLACK CAP - MINI SWITCH	6	
2	100-0033-0	CABLE TIE - PLT 1M-M,SMALL	2	
2	100-0072-0	GROMMET,.187 I.D.	4	
2	100-0096-0	KNOB,BLUE,6X15MM SPLINE SHAFT	6	<i>Note: as of 1999, gray knobs only available.</i>
2	100-0098-0	KNOB,GRAY,6X15MM SPLINE SHAFT	2	<i>Note: as of 1999, gray knobs only available.</i>
2	100-0099-0	KNOB,RED,6X15MM SPLINE SHAFT	3	<i>Note: as of 1999, gray knobs only available.</i>
2	100-0107-0	END BELL, X-FORMER BACKLINE	1	
2	111-7005-0	WASHER #4 FIBRE FLAT	1	
2	111-7011-0	WASHER #4 SPLIT	4	
2	111-8031-0	TR-BOLT 4-40 3/16 PHP CAD	2	
2	111-8061-0	TR-BOLT 4-40 3/8 PHP CAD	4	
2	112-9060-0	TR-BOLT 6-32 3/8 FHP B.O.	2	
2	113-0221-0	BOLT 8-32 1 3/4 PHP CAD	4	
2	113-6011-0	NUT 8-32 KEP CAD	4	
2	113-7001-0	WASHER #8 SHOLDER	8	
2	114-8121-0	TR-BOLT 8-32 3/4 PHP CAD	6	
2	130-0067-0	OVERLAY,BACKLINE,FRONT	1	
2	130-0068-0	OVERLAY,BACKLINE,REAR	1	
2	132-0576-0	BACKLINE CHASSIS	1	
2	114-6056-0	NUT 10-32 PRESS FOR STEEL	4	

LVL	PART#	DESCRIPTION	QTY	REF. DESIG.
2	120-0002-0	ALUM .080	320	
2	132-0578-0	BACKLINE HEAT SINK	1	
2	130-0070-0	BACKLINE HEATSINK EXTRUSION,1.25X.5X11.4	1	
2	202-0013-0	CORD, BACKLINE REVERB,RCA TO RCA	1	
2	206-0093-B	BACKLINE 100 PRE AMP	1	
2	001-0008-0	MC4053	1	U2
2	001-1030-0	LF353N DUAL JFET OP AMP	3	U1,3,5
2	001-1042-0	RC5532NB BI-POLAR OP-AMP	1	
2	001-3028-0	TL604 DUAL COMP ANALOG SWITCH	1	U4
2	010-2010-0	J113 N-JFET 35V 2MA TO-92	6	Q10,Q44,Q86,Q96,Q111,Q145
2	020-0024-0	1N4370 ZENER,2.4V,5%,400MW,DO-7	1	D133
2	020-0036-0	1N747A,ZENER,3.6V,5%,400MW,DO-35	1	D41
2	020-0120-0	1N759A,ZENER,12V,5%,400MW,DO-35	2	D7,D11
2	020-1103-0	1N914 ,RECT-FAST,200MA,100V,4NS,DO-35	1	D136
2	025-0101-0	LED-GREEN,6MCD,80 DEG,T-1	2	D83,D91
2	030-0223-0	CAP,CERAMIC AXIAL,223,30%,16V	3	C25,C64,C66
2	030-1103-0	CAP,CERAMIC AXIAL,103,30%,25V	4	C39,C74,C94,C97
2	030-2101-0	CAP,CERAMIC AXIAL,101,5%,50V	2	C14,C124A
2	030-2102-0	CAP,CERAMIC AXIAL,102,10%,50V	1	C82
2	030-2104-0	CAP,CERAMIC AXIAL,104,10%,50V,XR7,.3"	4	C132,C139,C169,C173
2	030-2222-0	CAP,CERAMIC AXIAL,222,10%,50V	3	C81,C120,C167
2	030-2224-0	CAP,CERAMIC AXIAL,224,20%,50V,XR7	6	C68,C72,C108,C112,C160,C168
2	030-2271-0	CAP,CERAMIC AXIAL,271,10%,50V	1	C28
2	030-2332-0	CAP,CERAMIC AXIAL,332,10%,50V	2	C31,C176
2	030-2333-0	CAP,CERAMIC AXIAL,333,5%,50V,X7R	1	C29
2	030-2470-0	CAP,CERAMIC AXIAL,47,5%,50V	1	C162
2	030-2473-0	CAP,CERAMIC AXIAL XR7,473,10%,50V	1	C162
2	030-2474-0	CAP,CERAMIC AXIAL Z5U,474,20%,50V	6	
2	030-2561-0	CAP,CERAMIC AXIAL,561,10%,50V	1	C121
2	031-1227-0	CAP,ELECTROLYTIC RADIAL,227,-10%+50%,25V	4	
2	032-3104-0	CAP,METALIZED POLYESTER,104,5%,63V	1	C13
2	032-3105-0	CAP,METALIZED POLYESTER,105,5%,63V	2	C18,C34
2	032-3334-0	CAP,METALIZED POLYESTER,334,5%,63V	1	C20

LVL	PART#	DESCRIPTION	QTY	REF. DESIG.
2	038-0106-0	CAP,ELECTROLITIC AXIAL TR,106,20%,16V	3	C45,C54,C149
2	038-0336-0	CAP,ELECTIOLYTIC AXIAL,336,20%,16V	5	C84,C100,C102,C137,C152
2	038-2105-A	CAP,ELECTROLITIC AXIAL TR,105,20%,50V	1	C181
2	038-2335-0	CAP,ELECTROLITIC AXIAL TR 335,20% 25V	10	C58,C71,C77,C115,C123,C127,C148,C175, C183,C184
2	051-0471-0	RES,CARBON FILM,47,OHM,1/4W,5%	1	R158
2	051-1002-0	RES,CARBON FILM,1K OHM,1/4W,5%	11	R4,R5,R9,R16,R53,R55,R89,R90,R117,R129, R146
2	051-1004-0	RES,CARBON FILM,100K OHM,1/4W,5%	3	R3,R185,R189
2	051-1005-0	RES,CARBON FILM,1M OHM,1/4W,5%	1	R15
2	051-1203-0	RES,CARBON FILM,12K OHM,1/4W,5%	14	R8,R12,R23,R42,R62,R63,R98,R113,R114, R126,R133,R147,R153,R164
2	051-2201-0	RES,CARBON FILM,220 OHM,1/4W,5%	2	R179,R184
2	051-2202-0	RES,CARBON FILM,2.2K OHM,1/4W,5%	13	R50,R59,R61,R70,R85,R95,R107,R130,R142 R151,R171,R175,R190
2	051-2203-0	RES,CARBON FILM,22K OHM,1/4W,5%	6	R19,R26,R27,R79,R92,R124
2	051-2204-0	RES,CARBON FILM,220K OHM,1/4W,5%	2	R128,R182
2	051-3302-0	RES,CARBON FILM,3.3K OHM,1/4W,5%	2	R110,R166
2	051-3303-0	RES,CARBON FILM,33K OHM,1/4W,5%	1	R106
2	051-4701-0	RES,CARBON FILM,470 OHM,1/4W,5%	2	R37,R144
2	051-4702-0	RES,CARBON FILM,4.7K OHM,1/4W,5%	8	R65,R73,R80,R101,R143,R159,R170,R172
2	051-4703-0	RES,CARBON FILM,47K OHM,1/4W,5%	5	R33,R36,R38,R88,R103
2	051-4704-0	RES,CARBON FILM,470K OHM,1/4W,5%	4	R47,R49,R105,R163
2	051-5602-0	RES,CARBON FILM,5.6K OHM,1/4W,5%	2	R76,R119
2	051-5604-0	RES,CARBON FILM,560K OHM,1/4W,5%	1	R78
2	052-0000-0	RES,METAL WIRE, 0 OHM, 1/4W,1%	22	R22,R30,R36A,R43,R48,R56,R57,R60,R93, R116,R125,R131,R134,R140,R155,R156, R157,R161,R165,R177,R178,R180
2	052-1213-0	RES,METAL FILM,12.1K OHM,1/4W,1%	2	R17,R21
2	052-3323-0	RES,METAL FILM,33.2K OHM,1/4W,1%	1	R46
2	070-0506-0	POT,50KA,9MM,PLASTIC KNUURL 14MM,.05W	0	
2	070-0508-0	POT,1K TRIM,6MM,SLOT,.3W	2	R91,R104
2	070-0510-0	POT,50K TRIM,6MM,SLOT,.3W	1	R6
2	070-0513-0	POT,50K-15A,9MM,METAL KNUURL,9MM,.1W	3	R35,R52,R109-bass, volume pots
2	070-0514-0	POT,50KB,LINEAR,9MM,METAL KNUURL 9MM,.1	2	R75-treble
2	070-0522-0	POT,2K-LINEAR,9MM,METAL KNUURL 9MM,.1W	4	R67,R122,R150,R154-reverb,presence,mids

LVL	PART#	DESCRIPTION	QTY	REF. DESIG.
2	070-0523-0	POT,2X50K LIN,9MM,METAL KNURL NOBLE.05	2	R24,R89-gain
2	090-0012-0	SWITCH,MINI PP,DPDT,.1A BRK/MAKE,PC TER	6	S1,S2,S3,S4,S5,S6-all switches
2	092-0075-0	JACK S2-BBB,1/4",S-TIP,S-RING,PC TERM	1	J2-footswitch jack
2	092-0076-0	JACK S2-BNB,1/4",S-TIP,PC TERM	4	J1,J3,J4,J5-all other front jacks
2	092-0077-0	RCA P.C. MOUNT FEMALE CONNECTOR	2	J6,J7
2	093-0100-0	HEADER,4X.156,MALE,RIGHT ANGLE,LOCK	1	P1
2	145-0093-0	BACKLINE PREAMP BOARD	1	
1	206-0095-A	BACKLINE 150 POWER AMP BOARD	1	
2	001-1030-0	LF353N DUAL JFET OP AMP	1	U1
2	010-0012-0	MPSA06 NPN 80V 500MA TO-92	2	Q59,Q75
2	010-1013-0	MPSA56 PNP 80V 500MA TO-92	2	Q32,Q37
2	010-2010-0	J113 N-JFET 35V 2MA TO-92	2	Q38,Q68
2	011-0243-0	MJE243 NPN 100V 4A TO-126	3	Q30,Q51,Q76
2	011-1253-0	MJE253 PNP 100V 4A TO-126	2	Q21,Q63
2	020-0024-0	1N4370 ZENER,2.4V,5%,400MW,DO-7	2	D40,D58
2	020-0100-0	1N758A,ZENER,10V,5%,400MW,DO-35	2	D47,D64
2	020-1103-0	1N914 ,RECT-FAST,200MA,100V,4NS,DO-35	6	D36,D41,D44,D66,D72,D73
2	020-2105-0	1N4002,RECT,1A,150V,DO-41	2	D22,D80
2	020-5352-0	1N5352,ZENER,15V,5%,5W,17-02	2	D35,D52
2	023-0140-0	BY224-600,BRIDGE RECT,5A,600V,SOT-112	1	BR1
2	030-1103-0	CAP,CERAMIC AXIAL,103,30%,25V	1	C48
2	030-2101-0	CAP,CERAMIC AXIAL,101,5%,50V	3	C8,C34,C61
2	030-2102-0	CAP,CERAMIC AXIAL,102,10%,50V	2	C26A,C75A
2	030-2224-0	CAP,CERAMIC AXIAL,224,20%,50V,XR7	1	C15
2	031-1227-0	CAP,ELECTROLYTIC RADIAL,227,-10%+50%,25V	3	C45,C53,C74
2	031-2478-0	CAP,ELECTROLYTIC RADIAL,478,20%,63V	2	C20,C46
2	032-8103-0	CAP,METALIZED POLYESTER,103,10%,400V	1	C82
2	038-0106-0	CAP,ELECTROLITIC AXIAL TR,106,20%,16V	1	C7
2	051-1001-0	RES,CARBON FILM,100 OHM,1/4W,5%	4	R23,R27,R65,R77
2	051-1002-0	RES,CARBON FILM,1K OHM,1/4W,5%	3	R18,R26,R78
2	051-1003-0	RES,CARBON FILM,10K OHM,1/4W,5%	1	R3
2	051-1203-0	RES,CARBON FILM,12K OHM,1/4W,5%	2	R61A,R43A
2	051-1502-0	RES,CARBON FILM,1.5K OHM,1/4W,5%	1	R49

LVL	PART#	DESCRIPTION	QTY	REF. DESIG.
2	051-2203-0	RES,CARBON FILM,22K OHM,1/4W,5%	4	R12,R13,R17,R19
2	051-3302-0	RES,CARBON FILM,3.3K OHM,1/4W,5%	1	R4
2	051-3904-0	RES,CARBON FILM,390K OHM,1/4W,5%	1	R16
2	051-4302-0	RES,CARBON FILM,4.3K OHM,1/4W,5%	3	R32A,R54,R79A
2	051-4701-0	RES,CARBON FILM,470 OHM,1/4W,5%	6	R28,R31,R42,R43,R62,R67
2	051-4703-0	RES,CARBON FILM,47K OHM,1/4W,5%	2	R10,R15A
2	051-5602-0	RES,CARBON FILM,5.6K OHM,1/4W,5%	3	R5,R39,R55
2	052-0000-0	RES,METAL WIRE, 0 OHM,1/4W,1%	4	R9,R33,R38A,R82
2	053-6801-0	RES,CARBON FILM 680 OHM,1W,5%	2	R1,R2
2	055-.150-0	RES,METAL OXIDE,.15 OHM,2W,5%	4	R11,R24,R57,R79
2	056-.330-0	RES,CERAMIC WW,.33 OHM,5W,10%	2	R69,R70
2	057-3301-0	RES,WIRE WOUND,330 OHM,10W,10%	2	R25,R56
2	070-0508-0	POT,1K TRIM,6MM,SLOT,.3W	1	R50
2	081-0031-0	INDUCTOR 1.5 UH WITH 10 OHM 2W RESISTOR	1	L71
2	091-0010-0	FUSE, 8A,125V,1/4X1 1/4,SLB	2	F1,F2
2	092-0010-0	PRINTED CIRCUIT TYPE .250 TABS	17	P2,3,4,5,6,7,8,9,10,11,12,13,14,15,16,17,18
2	092-0075-0	JACK S2-BBB,1/4",S-TIP,S-RING,PC TERM	2	J1,J2
2	092-0076-0	JACK S2-BNB,1/4",S-TIP,PC TERM	1	J3
2	093-0029-0	HEADER,4X.156,MALE,LOCK	1	P1
2	094-0004-0	HOLDER CLIP,FUSE,.5MM,P.C. MOUNT	4	
2	145-0094-0	LEAD 70W COMBO POWER AMP	1	