

FOOTSWITCH

SELECTOR BUTTON

The selector button allows the performer to obtain the output from the normal channel OR the effects channel. The selector may be thought of as an "either/or" type of control since it allows a choice of either normal or effects channels. As the name implies, the selector button **selects either channel** desired. It should be noted, however, that the selector button is functional when the instrument is plugged into either the series or the parallel jack.

COMBINER BUTTON

The **combiner button defeats** the **selector** button and allows both channels to be in the circuit at one time.

The selector button becomes inoperative as soon as the combiner button is depressed.

Distortion/Fuzz Button. Activates Distortion/Fuzz.

Reverb Button. Activates Reverb on both channels.

Tremolo Button. Activates tremolo.

FUNCTIONAL DIAGRAMS OF PARALLEL & SERIES MODE

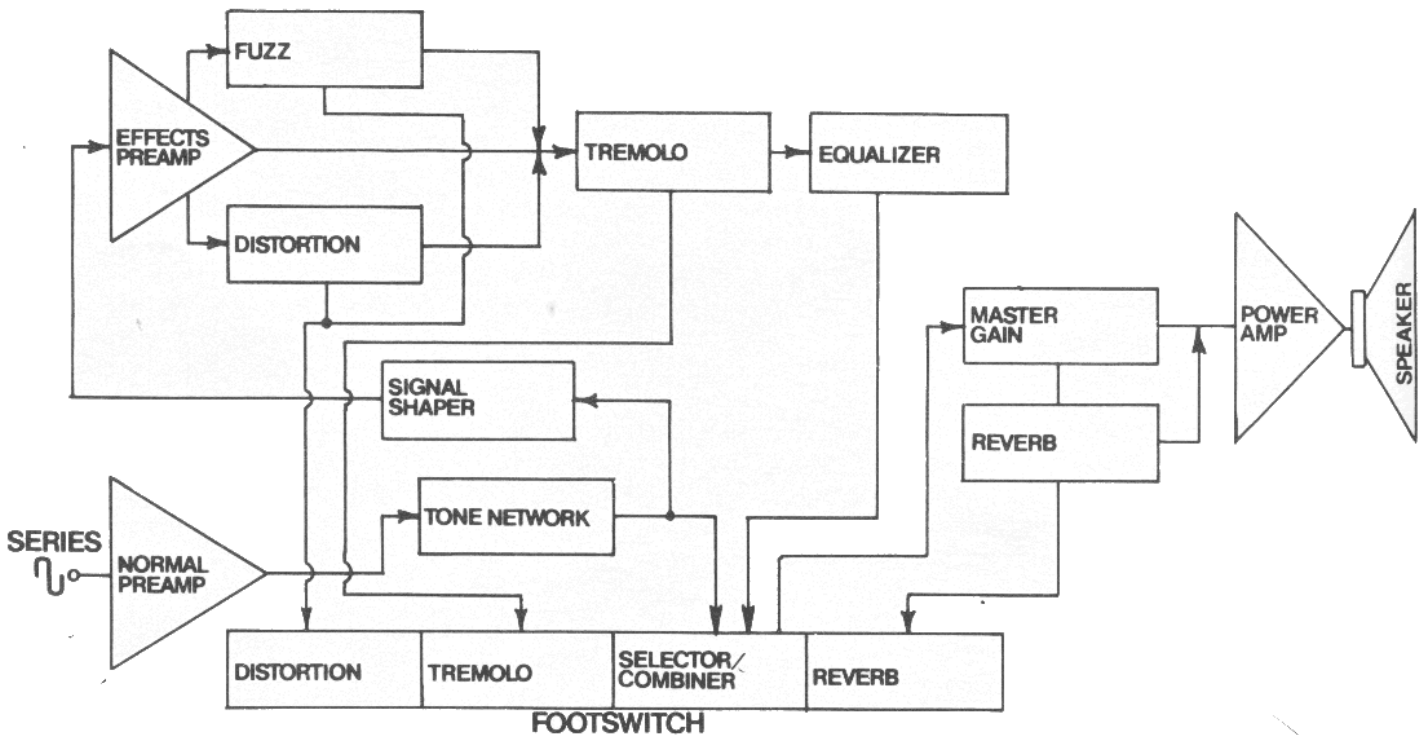
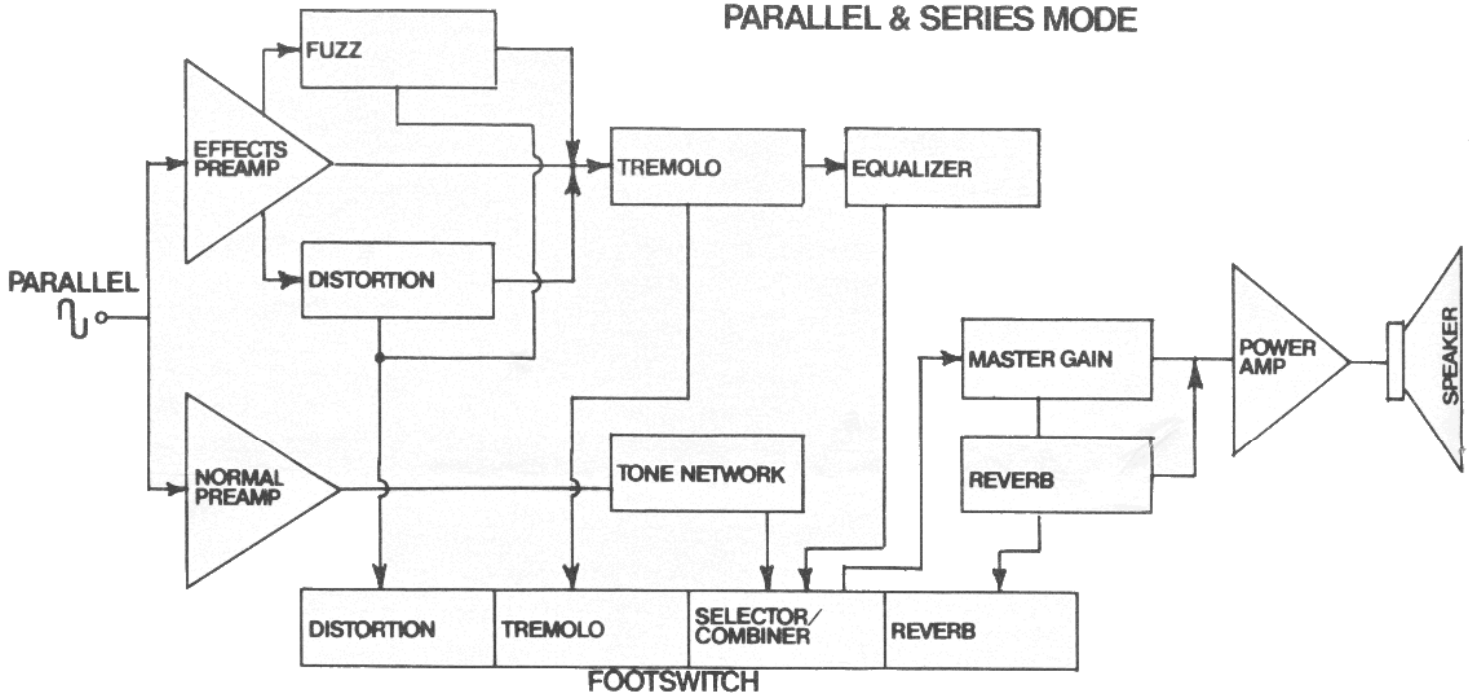

MUSICIAN (PRE AMP)

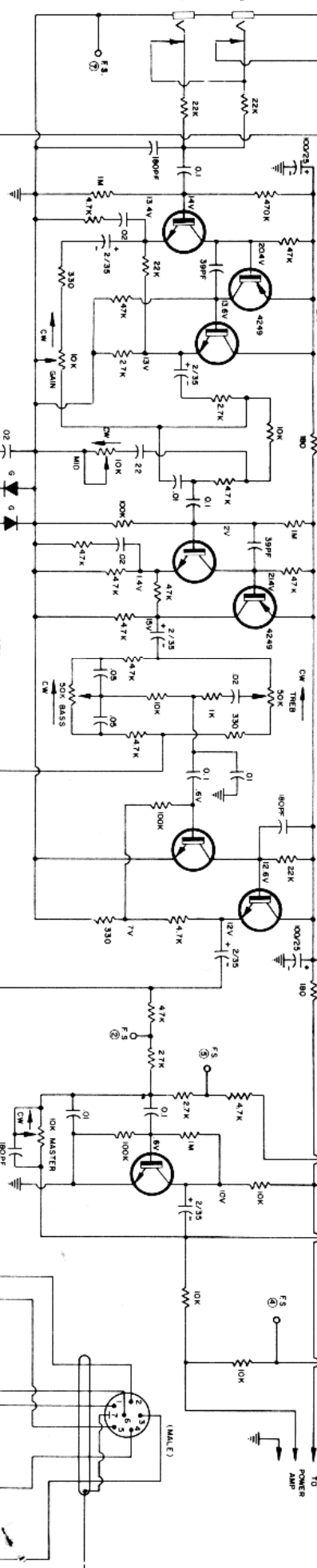
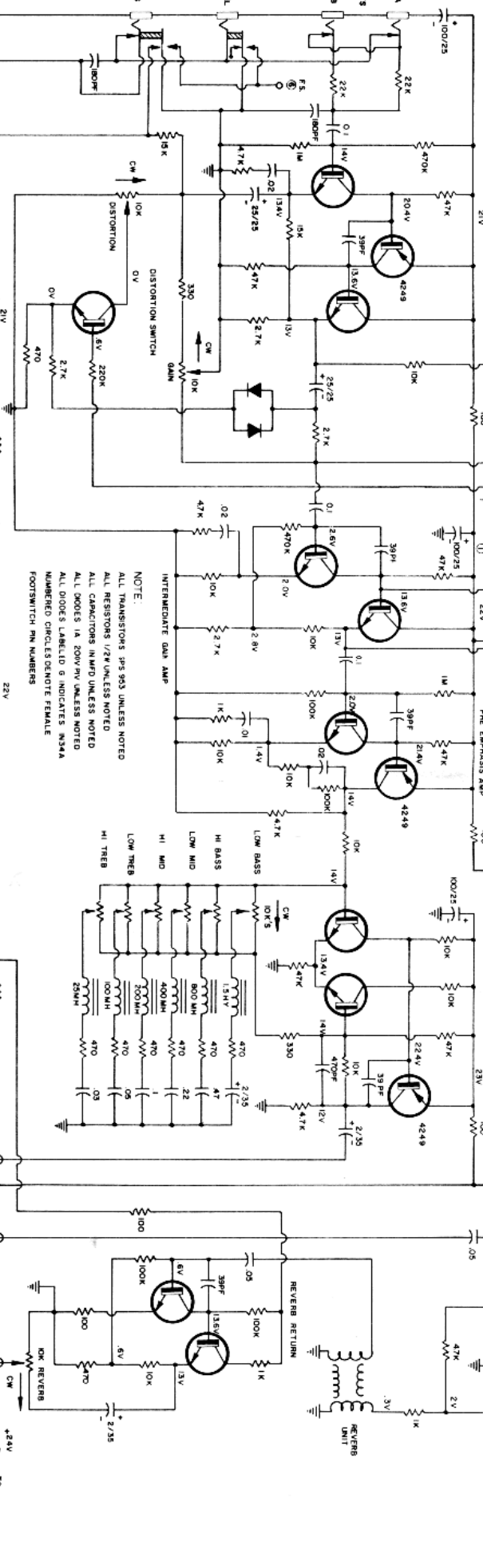
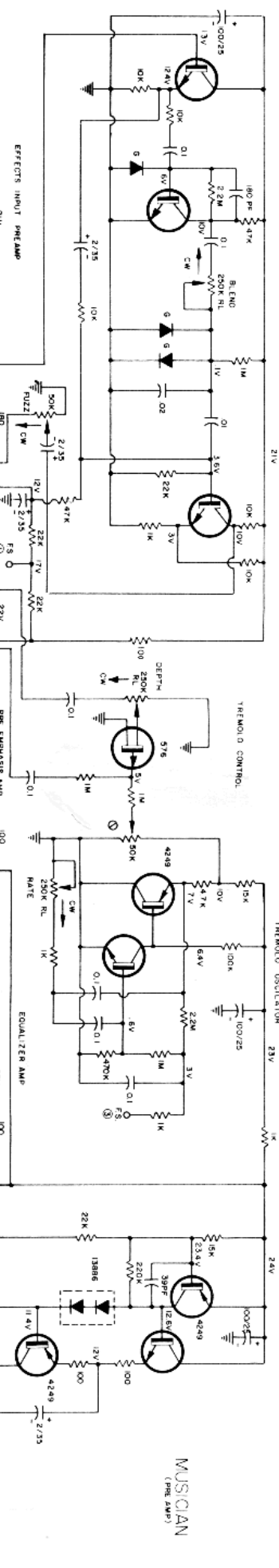

NOTE:
 ALL TRANSISTORS 95S UNLESS NOTED
 ALL RESISTORS 1/2W UNLESS NOTED
 ALL CAPACITORS 1/2W UNLESS NOTED
 ALL CROOKS 1A 200PV UNLESS NOTED
 ALL DIODES LABELLED G INDICATES M34A
 NUMBERED CIRCLES DENOTE FEMALE
 FOOTSWITCH PIN NUMBERS

