

# **SERVICE MANUAL**

## **VOX AC100CPH**



### **TABLE OF CONTENTS**

**ASSEMBLY SKETCH : 2**  
**SCHEMATIC DIAGRAM:3-6**  
**COMPONENT LOCATION: 7-9**  
**PARTS LIST: 10-12**



**Issued: Apr.18, 2007**  
**Ver.1**

# ★ ASSEMBLY SKETCH

AC100CPH

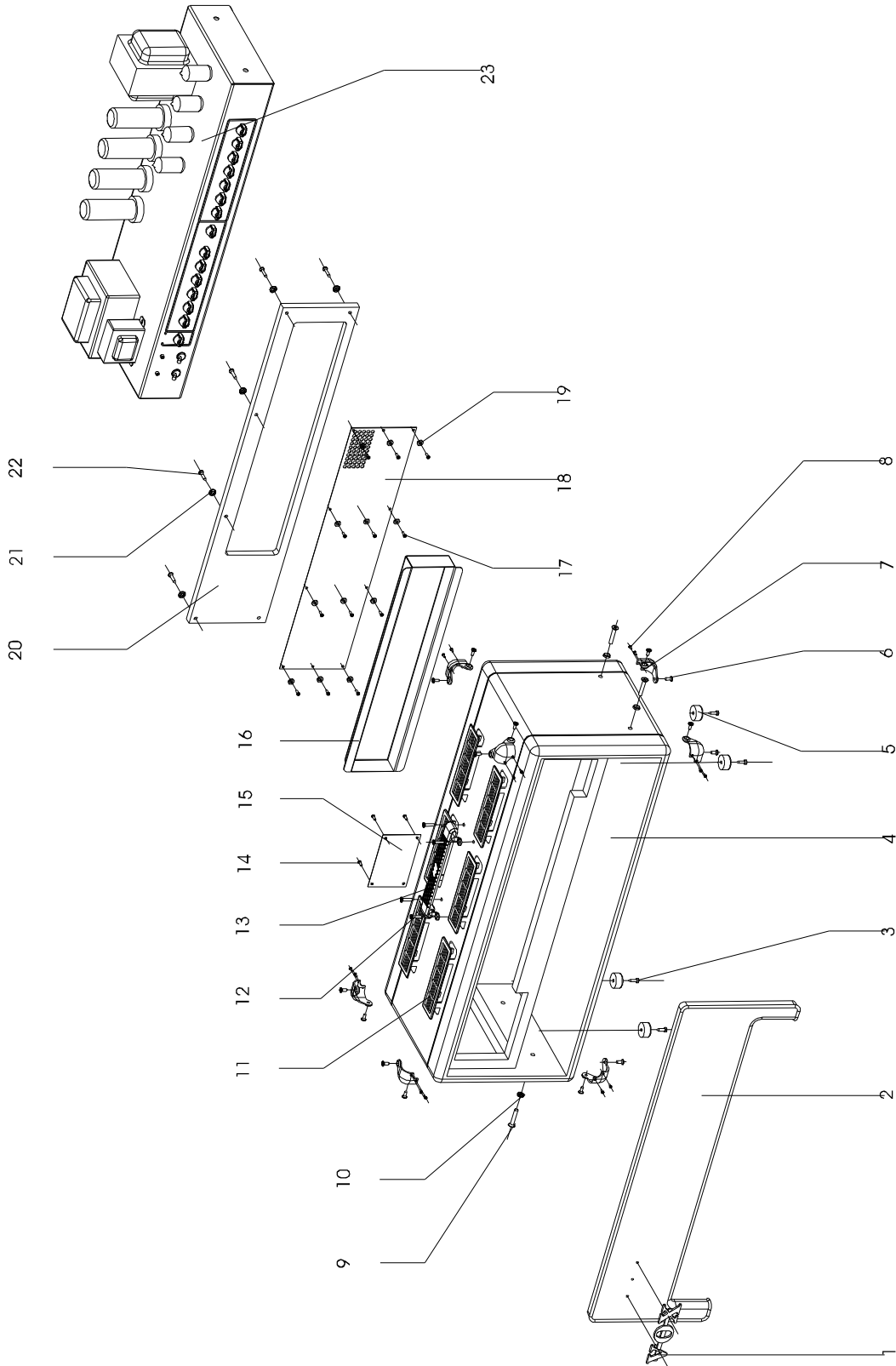

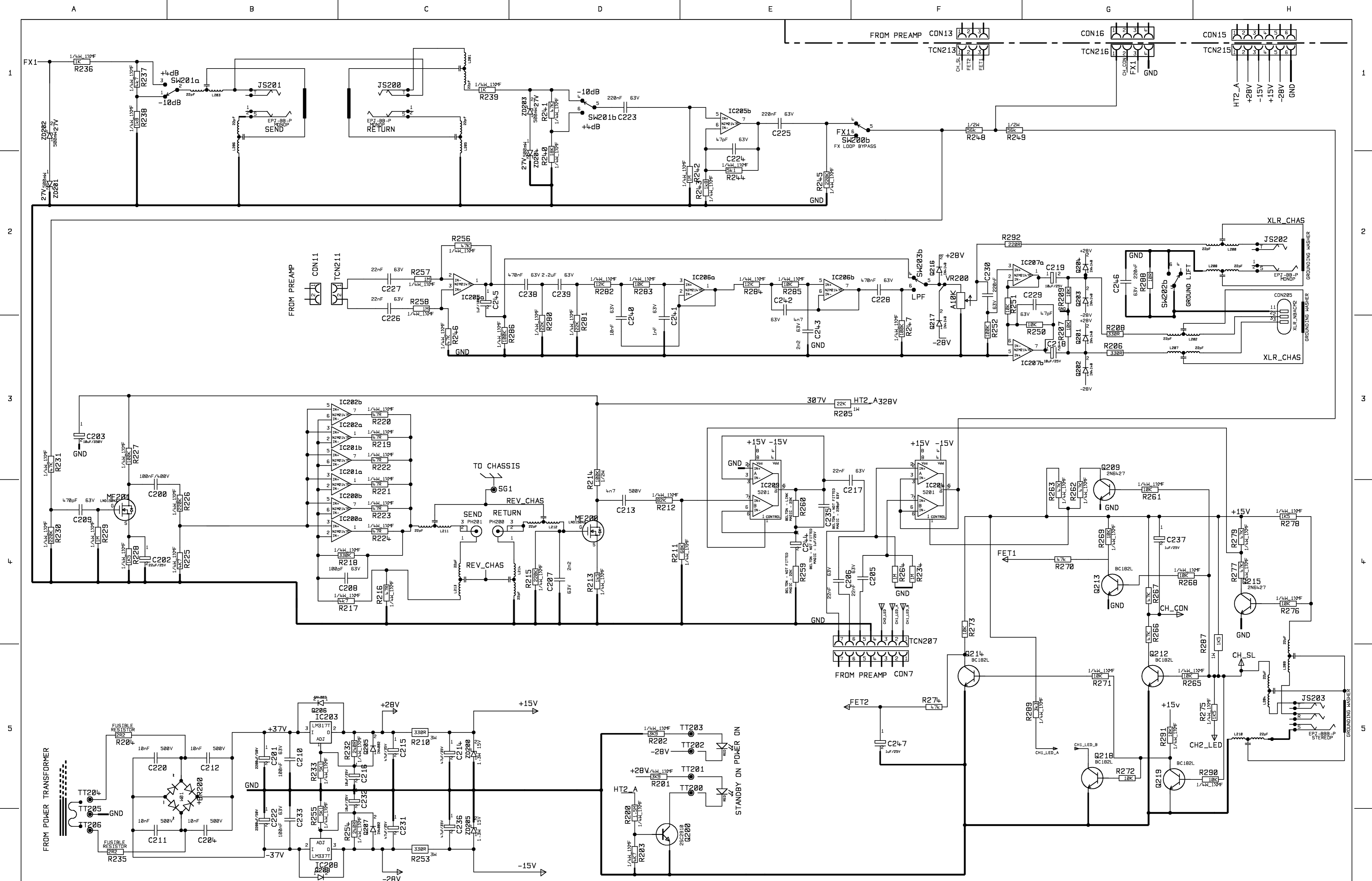

# VOX R&D UK

division of KORG EUROPE Ltd.

2b	20/06/06	CHANGE POWER RATING OF R210 & R253	DC
ISS	DATE	CHANGE	SIGNED

64 ALSTON DRIVE, BRADWELL ABBEY, MILTON KEYNES, MK13 9HB, ENGLAND. +44 (0) 1908 313511

MODEL	AC50 & AC100	TITLE	AC50 & AC100 REAR PANEL I/O SCHEMATIC
ISSUE	ISS3b	DRAWN	DC 26/09/06
CHECKED		DWG.No	
APPROVED			AC50_AC100_IO_ISS3b.DGM

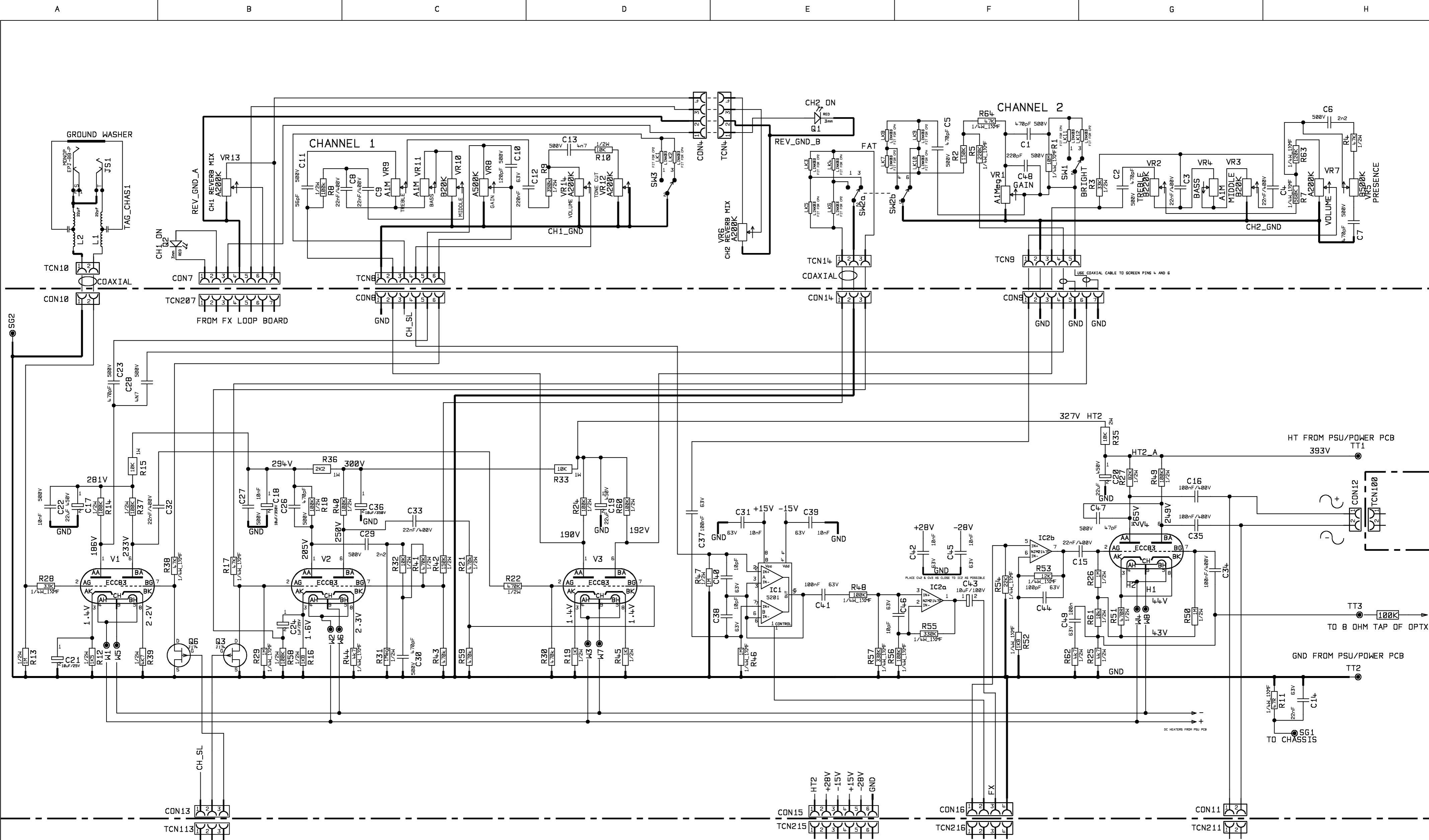

LV PWR, REVERB AND FX LOOP PCB

3	29/08/06	ADD LINKS FOR AC50CP2 COMPATIBILITY	DC
ISS	DATE	CHANGE	SIGNED

**VOX R&D UK** division of KORG EUROPE Ltd.  
 64 ALSTON DRIVE, BRADWELL ABBEY, MILTON KEYNES, MK13 9HB, ENGLAND. +44 (0) 1908 313511

MODEL	AC50 & AC100	TITLE	AC50 & 100 MODERN PREAMP
ISSUE	ISS3	DRAWN	DC 29/08/06
CHECKED		DWG.No	
APPROVED			AC50_100_PREAMP_ISS3.DGM

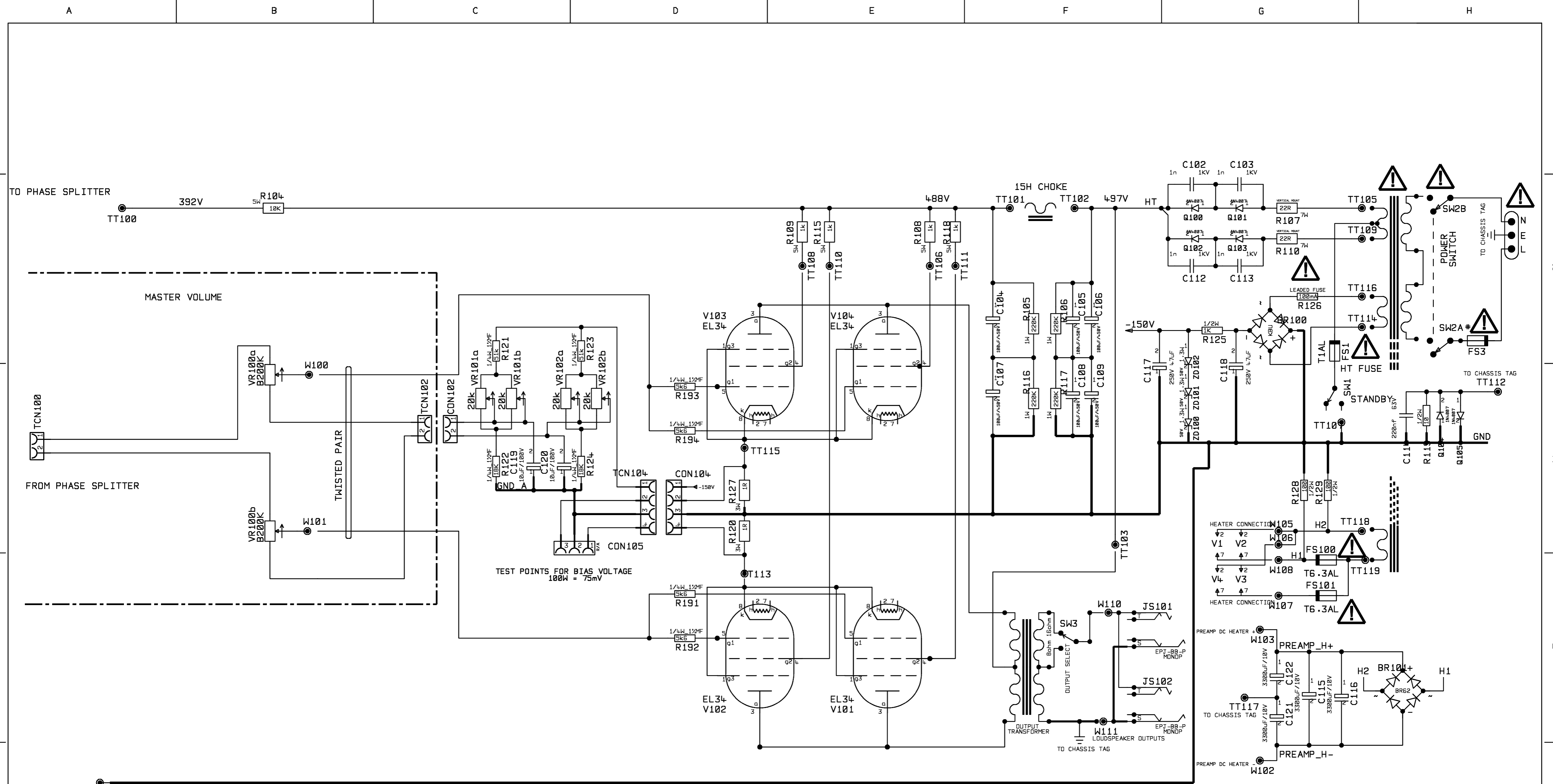

**!** SAFETY CRITICAL COMPONENT  
 REPLACE ONLY WITH SAME  
 TYPE & RATING  
 IF IN DOUBT CONTACT SUPPLIER

2c	01/09/05	CHANGE R125 to 1K 1/2 W, CHANGE R126 TO 100mA FUSE	DC
2b	07/08/05	CHANGE R122 & R124 TO 18K	DC
2a	24/05/05	ADD VOLTAGES AND WARNINGS	DC
ISS	DATE	CHANGE	SIGNED

**VOX R&D UK** division of KORG EUROPE Ltd.  
 64 ALSTON DRIVE, BRADWELL ABBEY, MILTON KEYNES, MK13 9HB, ENGLAND. +44 (0) 1908 313511

MODEL	AC100	TITLE	AC100 POWER OUTPUT
ISSUE	ISS2c	DRAWN	DC 01/09/06
CHECKED		DWG.No	
APPROVED			AC100_POWER_STAGE_ISS2c.DGM

★ SCHEMATICS DIAGRAM(FOOT SWITCH)

---

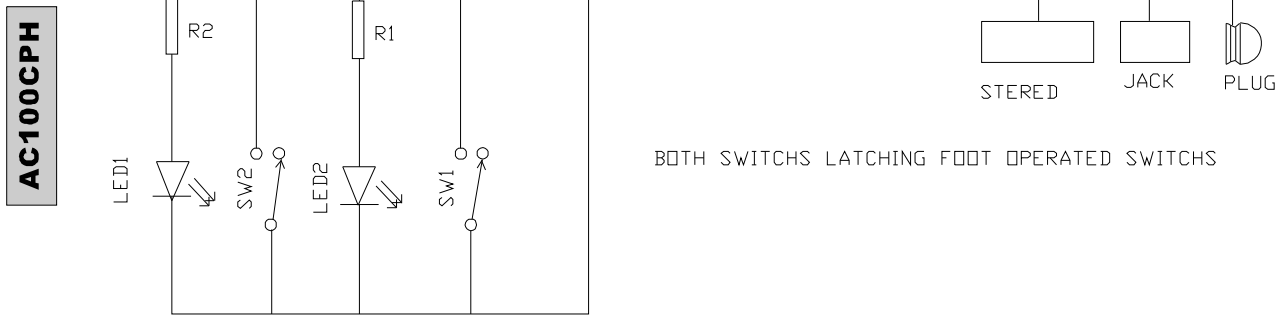

# ★ PCB COMENENTS LOCATION DRAWING

**AC100CPH**

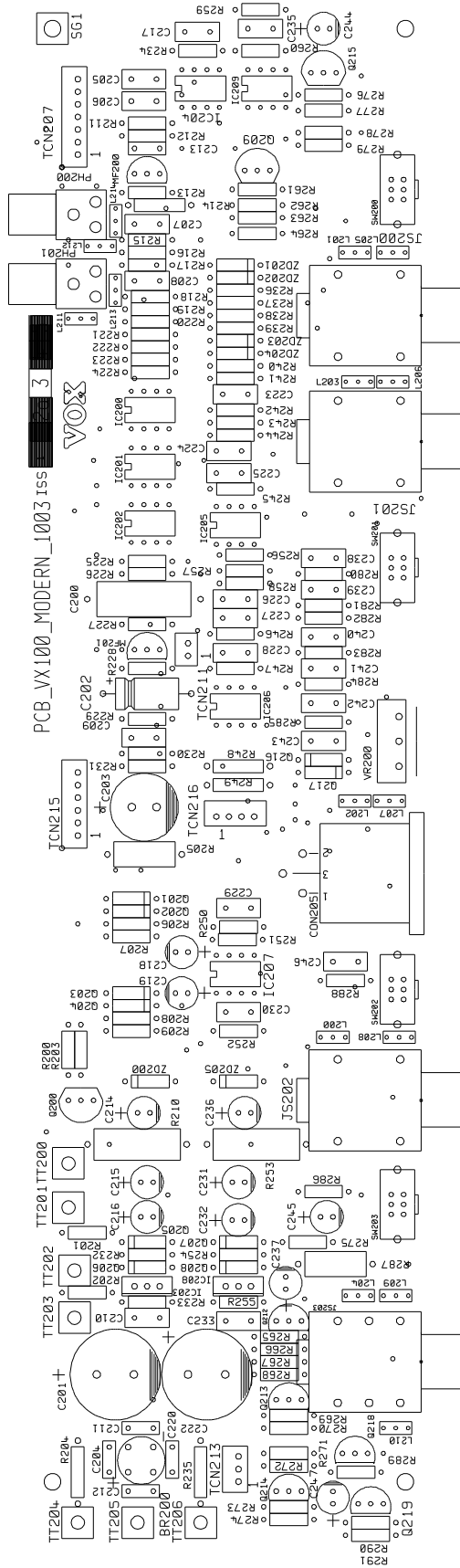

★ PCB COMENENTS LOCATION DRAWING

LAYER 7 (SILK SCREEN ARTWORK)  
ISSUE - ISS3

AC100CPH

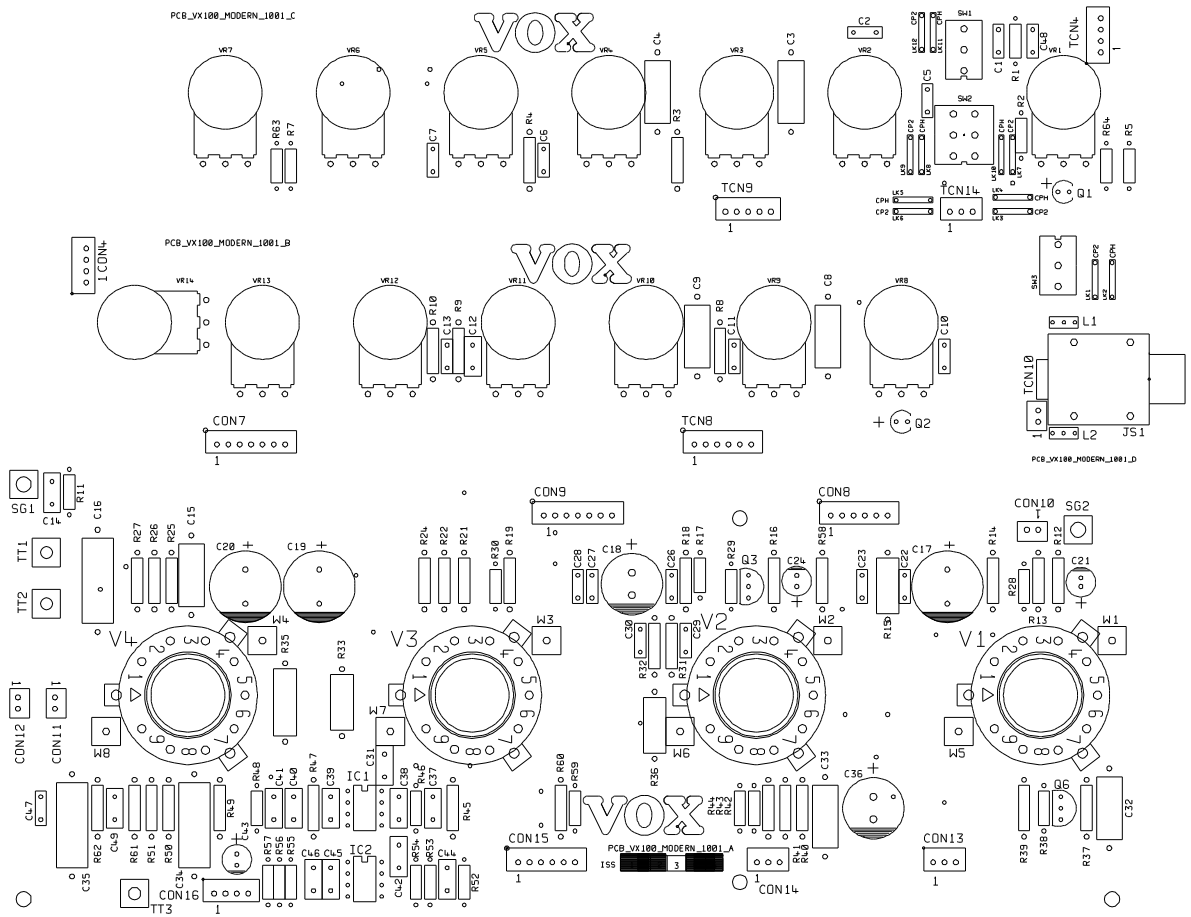



AC100CPH

LAYER 7 (SILK SCREEN ARTWORK)  
ISSUE - ISS2

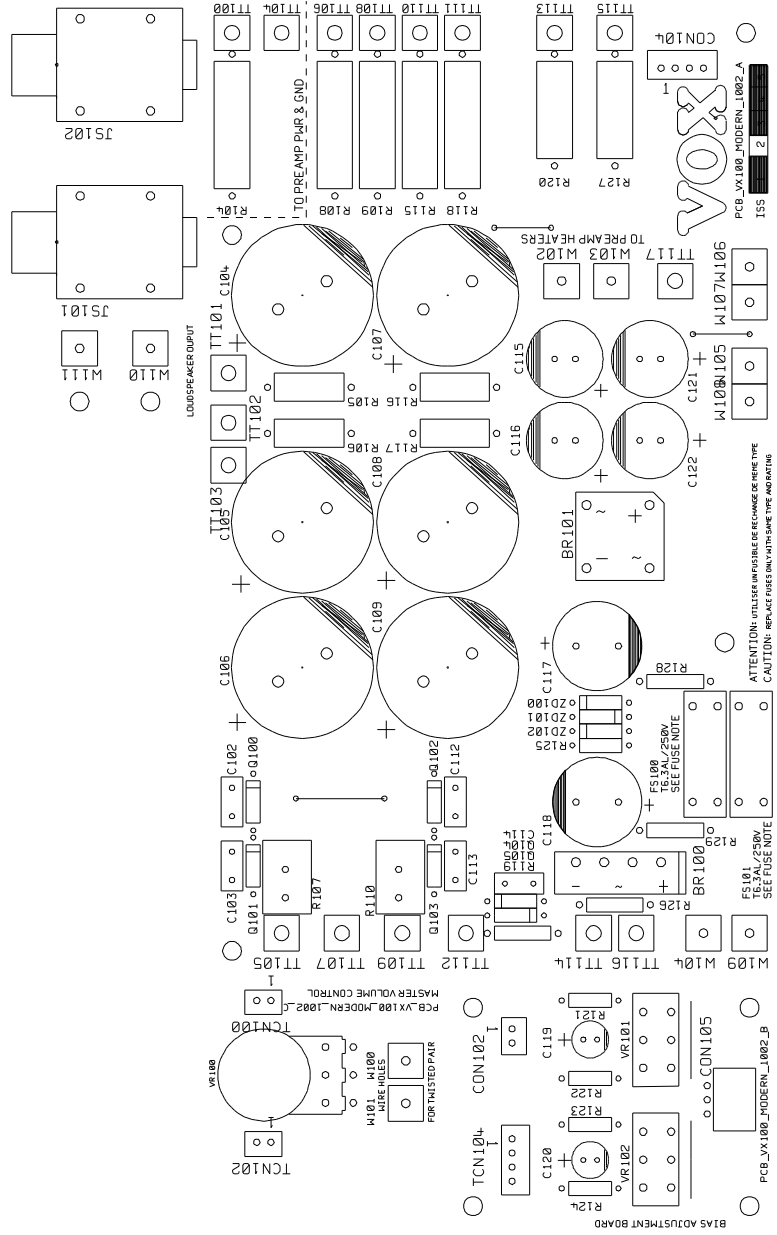

**VOX AC100CPH Parts List**

Part Number	Part Name	Description/Reference	QTY
530000000717	CABINET AC100CPH	VOX vinyl, black sprayed inside	1
530000000708	FRONT BAFFLE AC100CPH	diamond veneer, PU paint, white piping	1
530000000710	BACKBOARD	VOX vinyl, black sprayed inside	1
530000000716	REAR GRILL	Φ6 hole, black sprayed	1
530000000574	GOLDEN STRINGS	Set in the cabinet	3.8
530000000057	LOGO PLATE 217-1327000001	golden "VOX"	1
530000000063	RUBBER FOOT 25*12.5 W CUSHION	Φ25×12.5,with steel washer inside	4
530000000573	VENT GRILLE	be made from ABS	6
530000000064	HANDLE AC15CC1	PVC&Al-alloy	1
530000000060	PLASTIC CORNER 406-1308000000	be made from Nylon6	8
530000000705	EVA SPONGE 15.0W*2.0T	self adhesive 15.0W*2.0T	1.2
530000000645	REVERB PRVL3EB2C1B LONG SPRING	PRVL3EB2C1B,Long 3 Spring,RUBY	1
530000000072	FOOT SWITCH VF002	VF002	1
530000000725	AC100 AMPLIFIER	MAINS INPUT 230V	1
530000000679	FUSE WIRE (US)	US,EX,JP	(1)
530000000678	FUSE WIRE T2.5AL/250(UK)	UK,AU,GE	(1)
530000000670	TRANSFORMER022-1114042288R(US)	US,EX	(1)
530000000671	TRANSFORMER022-1114042289R(UK)	UK	(1)
530000000668	TRANSFORMER022-1114042286R(AU)	AU	(1)
530000000672	TRANSFORMER022-1114042290R(GE)	GE	(1)
530000000669	TRANSFORMER022-1114042287R(JP)	JP	(1)
530000000611	POWER CABLE (120V US/EX)	US,EX	(1)
530000000081	POWER CABLE AC15(230V UK)	UK,GE	(1)
530000000695	POWER CORD (AU)	AU	(1)
530000000078	POWER CABLE AC15(100V JP)	JP	(1)
530000000700	REVERB POP PCB		(1)
530000000113	PHONE SOCKET LS-2031-6	JS203	1
530000000692	PHONE JACK(SOCKET WHITE)	PH200	1
530000000691	PHONE JACK (SOCKET RED)	PH201	1
530000000112	PHONE SOCKET LS-2031-4	JS200,JS201, JS202	3
530000000688	MALE XLR (RIGHT PCB MOUNT)	CON205	1
530000000651	IC LM317T	IC203	1
530000000652	IC LM337T	IC208	1
530000000103	IC NJM2120D	IC204,209	2
530000000104	IC NJM2147D	IC200,201,202,205,206,207	6
530000000674	EMI FILTER DSS6NC52A271	L200-210	11
530000000685	SSW DPDT RA SV710100202	SW200-203	4
530000000579	FUSIBLE RESISTOR 2R2/1WATT	R204,235	2
530000000657	STRAIGHT POT MONO A10K	VR200	1
530000000684	BRIDGE RECTIFIER W01	BR200	1
530000000696	DIODE 1N4148	Q201,202,203,204,216,217	6
530000000697	DIODE 1N4002	Q205,206,207,208	4
530000000106	FET LND150N3	MF200, 201	2
530000000653	TRANSISTOR 2N6427	Q209,215	2
530000000105	TR 2SC2910 AUDION	Q200	1
530000000427	TR BC182L	Q212,213,214,218,219	5
530000000120	MANOSTAT IN4744A 15V-1W	ZD200,205	2
530000000121	MANOSTAT 27V 1/2W IN5254	ZD201,202,203,204	4
530000000116	CONNECTOR (TO JS-1001-02)	TCN211	1
530000000117	CONNECTOR DJ2802-3P	TCN213	1
530000000693	0.1" PITCH CONNECTOR 4WAY	TCN216	1

Part Number	Part Name	Description/Reference	QTY
530000000694	0.1" PITCH CONNECTOR 6WAY	TCN215	1
530000000115	GROUP PIN 7P 2.5MM	TCN207	1
530000000701	PREAMP POP PCB		(1)
530000000112	PHONE SOCKET LS-2031-4	JS1	1
530000000103	IC NJM2120D	IC1	1
530000000104	IC NJM2147D	IC2	1
530000000687	PCB TOGGLE SWITCH DPDT00B1N01	SW2	1
530000000686	PCB TOGGLE SWITCH SPDT00B1N01	SW1,SW3	2
530000000426	FET J174	Q3,Q6	2
530000000654	LED 234HD RED	Q1	1
530000000655	LED 234GD/E-A GREEN	Q2	1
530000000723	VT9 PCB MOUNT VALVE BASE	V1,V2,V3,V4	5
530000000108	POTENTIOMETER A1M AC30	VR1,VR4,VR9,VR11	4
530000000661	POT RA ALPHA RV16A 41#A200K	VR7,VR12,VR14,V6,V13	5
530000000110	POTENTIOMETER A500K AC30	VR8	1
530000000663	POT RA ALPHA RV16A 41#B500K	VR5	1
530000000659	POT RA MONO ALPHA RV16A41#B20K	VR3,VR10	2
530000000662	POT RA ALPHA RV16A 41#B220K	VR2	1
530000000116	CONNECTOR (TO JS-1001-02)	CON10,CON11,CON12	3
530000000117	CONNECTOR DJ2802-3P	CON13,CON14	2
530000000693	0.1" PITCH CONNECTOR 4WAY	CON16,CON4	2
530000000694	0.1" PITCH CONNECTOR 6WAY	CON8,CON15	2
530000000115	GROUP PIN 7P 2.5MM	CON9	1
530000000703	PSU POP PCB		(1)
530000000112	PHONE SOCKET LS-2031-4	JS101,JS102	2
530000000114	FUSE BASE	FS100,101	4
530000000680	FUSE WIRE T6.3A/250V	FS100,101	2
530000000675	FUSE WIRE T100MA 205V	R126	1
530000000660	POT RA ST ALPHA RV16A 41#B200K	VR100	1
530000000658	STRAIGHT STEREO POT 20K	VR101,102	2
530000000689	0.1" PITCH CONNECTOR 3WAY	CON105	1
530000000683	BRIDGE RECTIFIRE BR62(KBPC602)	BR101	1
530000000682	BRIDGE RECTIFIRE KBU(KBU8D)	BR100	1
530000000119	DIODE IN4007	Q100-105	6
530000000698	ZENER DIODE 51V1.3W	ZD100, 101, 102	3
530000000116	CONNECTOR (TO JS-1001-02)	CON102	1
530000000693	0.1" PITCH CONNECTOR 4WAY	TCN104,CON104	2
530000000699	CHOKE COIL 15H		1
530000000673	OUTPUT TRANS 022-1114042291R		1
530000000089	FUSE BASE R3-11 5*20		1
530000000642	SW 6021-K1C1T2(100/230/240V)		2
530000000677	FUSE WIRE T1AL/250V		1
530000000678	FUSE WIRE T2.5AL/250(UK)		1
530000000073	RED LED 333HD/E-A	POWER	1
530000000656	LED GREEN 333GD/E-A	STANDBY	1
530000000724	VALVE HOLDER		4
530000000721	VALVE EL34	V101,V102,V103,V104	4
530000000097	VALVE ECC83(12AX7)	V1,V2,V3,V4	4
530000000690	POWER SOCKET		1
530000000715	MAIN CHASSIS AC100CPH		1
530000000707	ANODISED PANEL AC100CPH		1
530000000720	ADJUSTMENT PLATE		1
530000000704	VOX MINI KNOB		18

Part Number	Part Name	Description/Reference	QTY
530000000705	EVA SPONGE 15.0W*2.0T		1
530000000712	TAPPED METAL SPACER(M3×5.5)	Support preamp PCB、Power PCB	10
530000000711	TAPPED METAL SPACER(M3×6)	Support adjustment PCB	4
530000000713	TAPPED METAL SPACER(M3×40)	Support reverb board	4
530000000719	SPRING FINGER	Touch aluminum foil	2