

AC30 SILVER JUBILEE (VOX LTD)

Vox

VUX

LONDON NWS 1HE
TELEPHONE: 01 247 5151
TELEX 23170 A/BROADEN

AC30 TOP BOOST
LVER JUBILEE

DRAWING NO. AC30/T8

RIGHT DIAGRAM COPYRIGHT
UNAUTHORIZED
REPRODUCTION

DRAWN BY: A-D-ERS
CHANGE 1:
CHANGE 2:

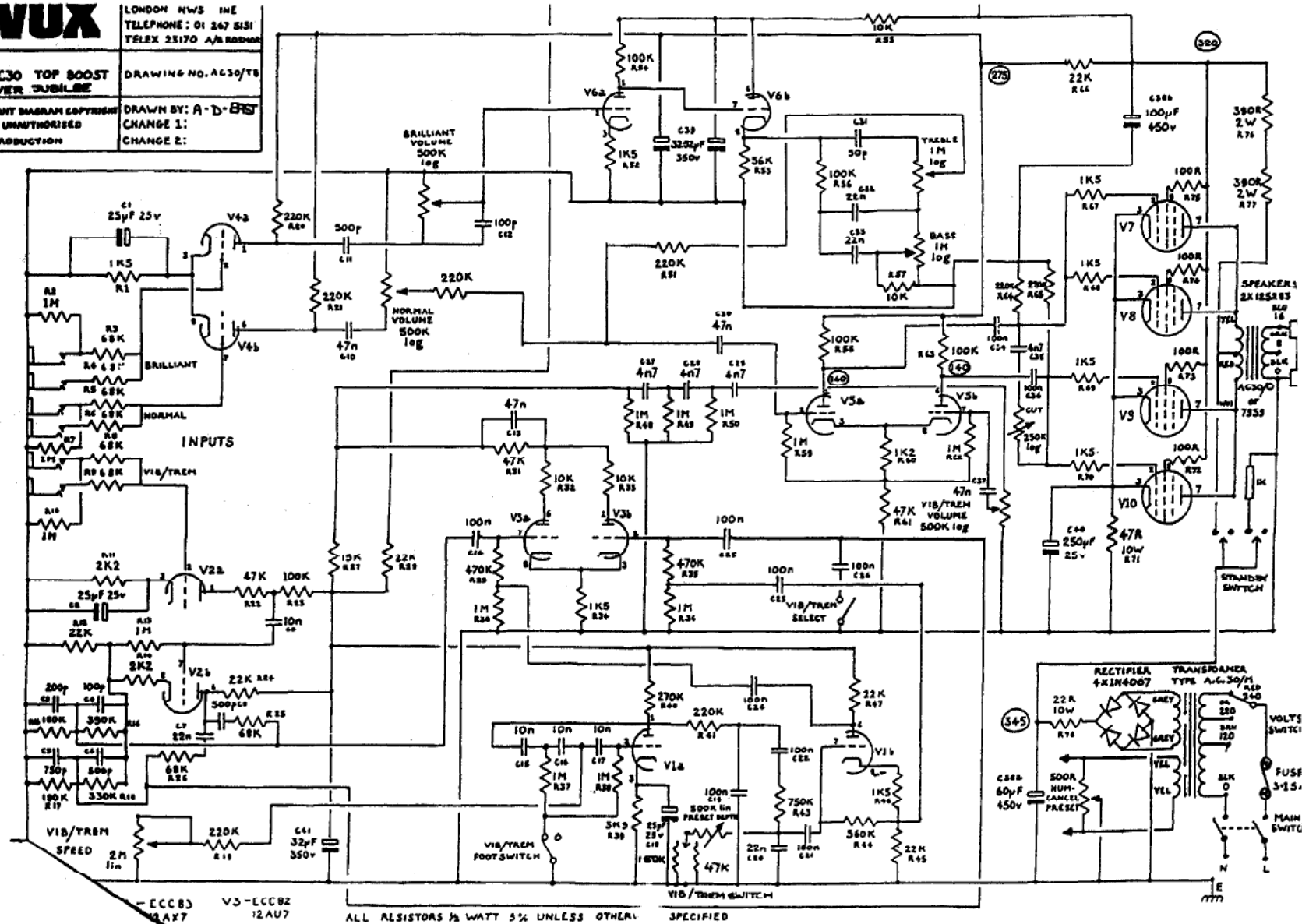

- ECC83
6AX7 V3-LCC8Z
12AU7

ALL RESISTORS 1/2 WATT 5% UNLESS OTHERWISE SPECIFIED

VIB/TREM SWITCH

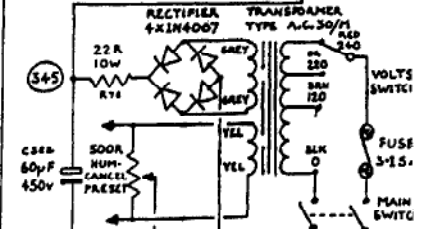

AC30 (S.S. RED)

Vox

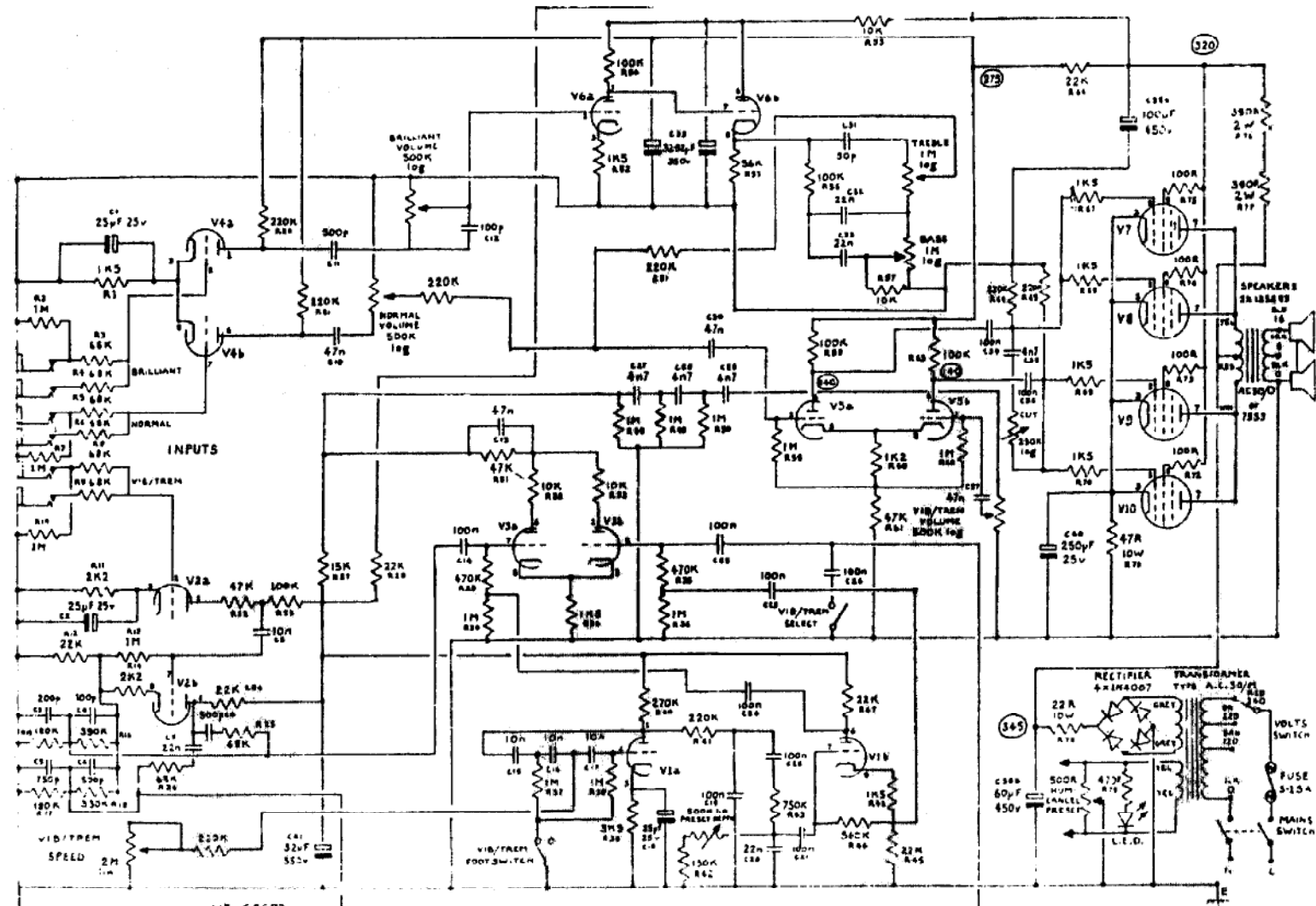

V1,2,4,5,6 - ECC83
V3 - ECC82
V7,8,9,10 - EL84

ALL RESISTORS 1/2 WATT 5% UNLESS OTHERWISE SPECIFIED

TRAINWRECK CIRCUITS
59 PRESTON ROAD
COLONIA, N. J. 07067
(201) 381-8129

AC30 TOP BOOST REISSUE (1994)

Vox

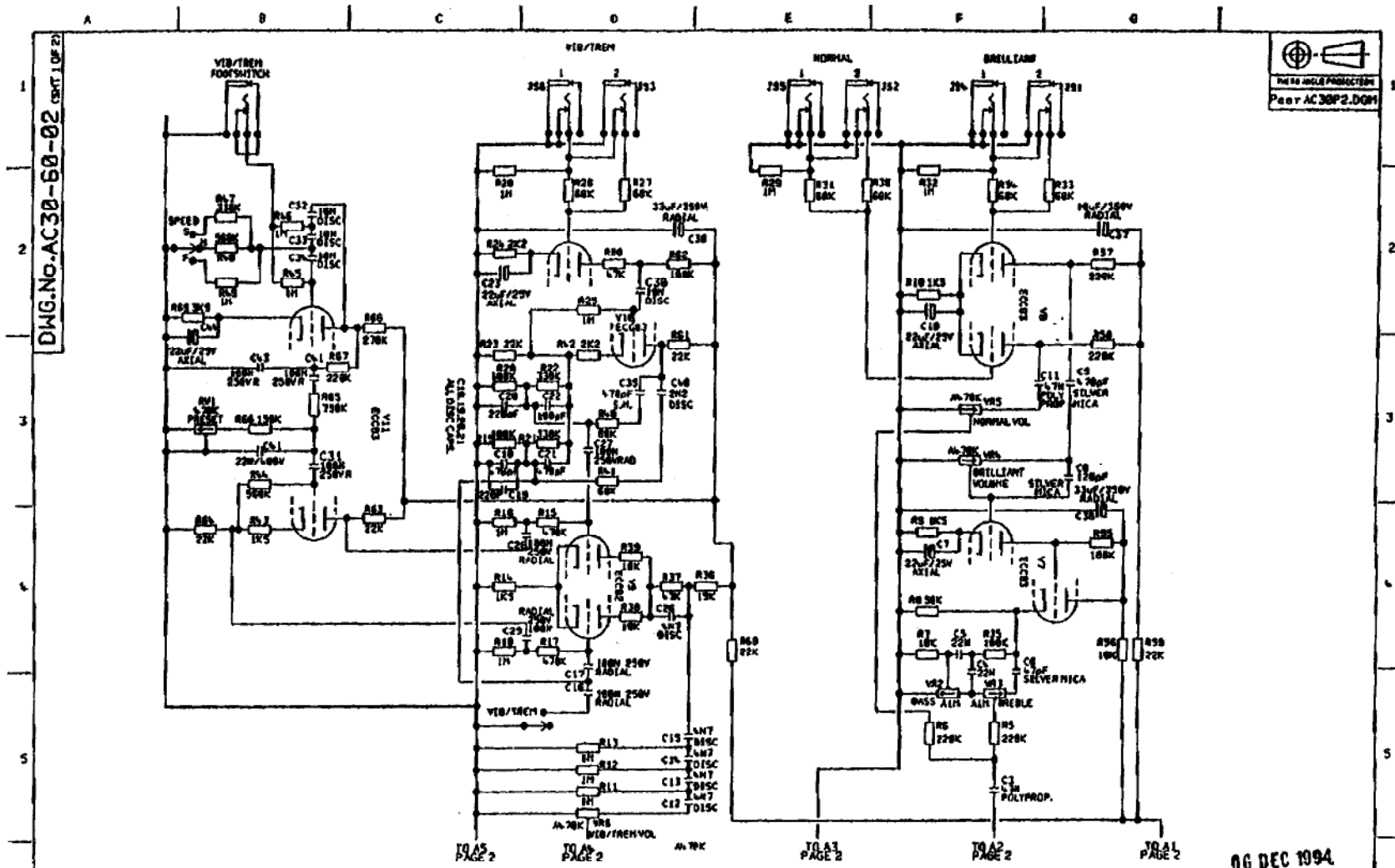

UNSPECIFIED MODEL DATA				REVISIONS		TITLE	
REV	DATE	BY	CHKD	NO.	DESCRIPTION	DATE	ISSUE
1	05/12/95	A		1			1
2	15-1-96	B		2			2
3	17/7/97	C		3			3
4	8/1/98	D		4			4
5	8/1/98	E		5			5
6	8/1/98	F		6			6
7	8/1/98	G		7			7

REV	DATE	BY	CHKD	NO.	DESCRIPTION	DATE	ISSUE
1	05/12/95	A		1			1
2	15-1-96	B		2			2
3	17/7/97	C		3			3
4	8/1/98	D		4			4
5	8/1/98	E		5			5
6	8/1/98	F		6			6
7	8/1/98	G		7			7

REV	DATE	BY	CHKD	NO.	DESCRIPTION	DATE	ISSUE
1	05/12/95	A		1			1
2	15-1-96	B		2			2
3	17/7/97	C		3			3
4	8/1/98	D		4			4
5	8/1/98	E		5			5
6	8/1/98	F		6			6
7	8/1/98	G		7			7

06 DEC 1994

AC30 REISSUE

TITLE
AC30 TOP BOOST
(SHT 1 OF 2)

DWG NO
AC30-60-02

ISSUE
5

AC30 TWIN REVERB (W/MOD)

Vox

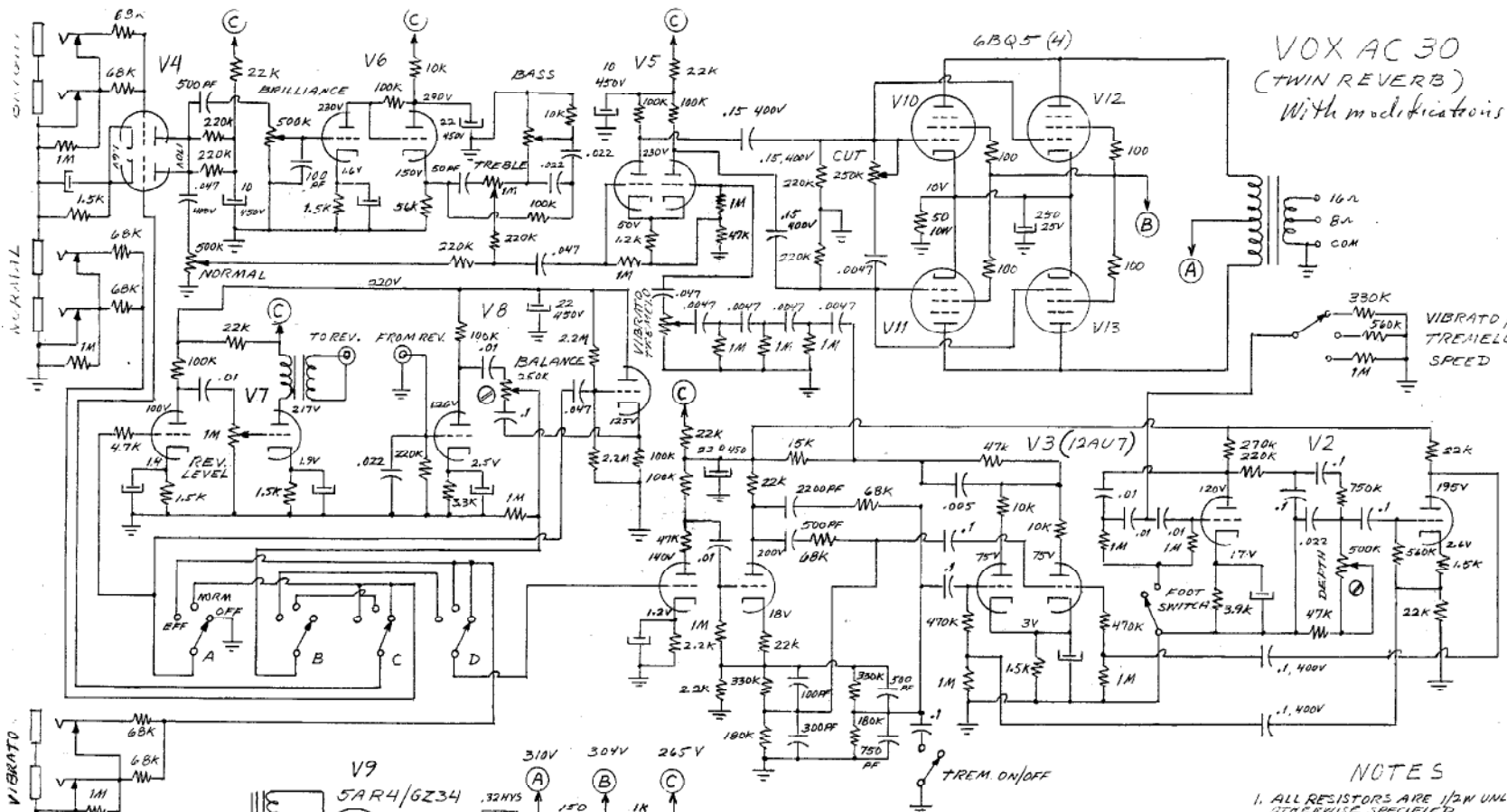

VOX AC 30
(TWIN REVERB)
With modifications

VIBRATO /
TREBLE
SPEED

NOTES

1. ALL RESISTORS ARE 1/2W UNLESS OTHERWISE SPECIFIED.
2. ALL CAPACITOR VALUES ARE IN MF UNLESS OTHERWISE NOTED.
3. TUBES V1, V2 AND V4 - V8 : 12AX7.
4. ALL CATHODE BYPASS CAPACITORS ARE 25M AT 25V UNLESS NOTED.

CHASSIS, REAR VIEW

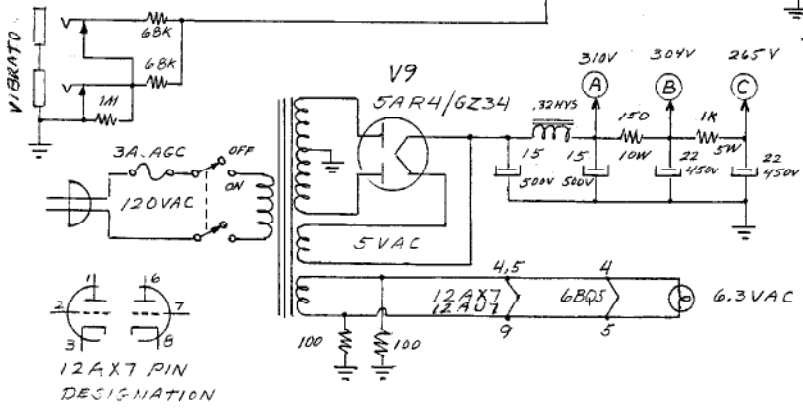
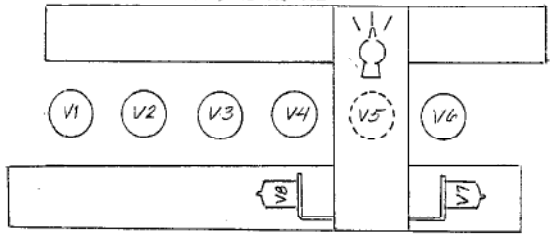

12AX7 PIN
DESIGNATION

Music II
Hills, HI
11-1-61