

Service Manual

AC30CC2

AC30CC2X

CONTENTS

Assembly Sketch	: Page 2
PCB Components Location	: Page 3-4
Block Diagram	: Page 5
Circuit Diagram	: Page 6-10
Parts List	: Page 11-13

1st Edition
Issued date: Oct. 21, 2005
Issued by: KORG INC.

★ ASSEMBLY SKETCH

AC30CC2

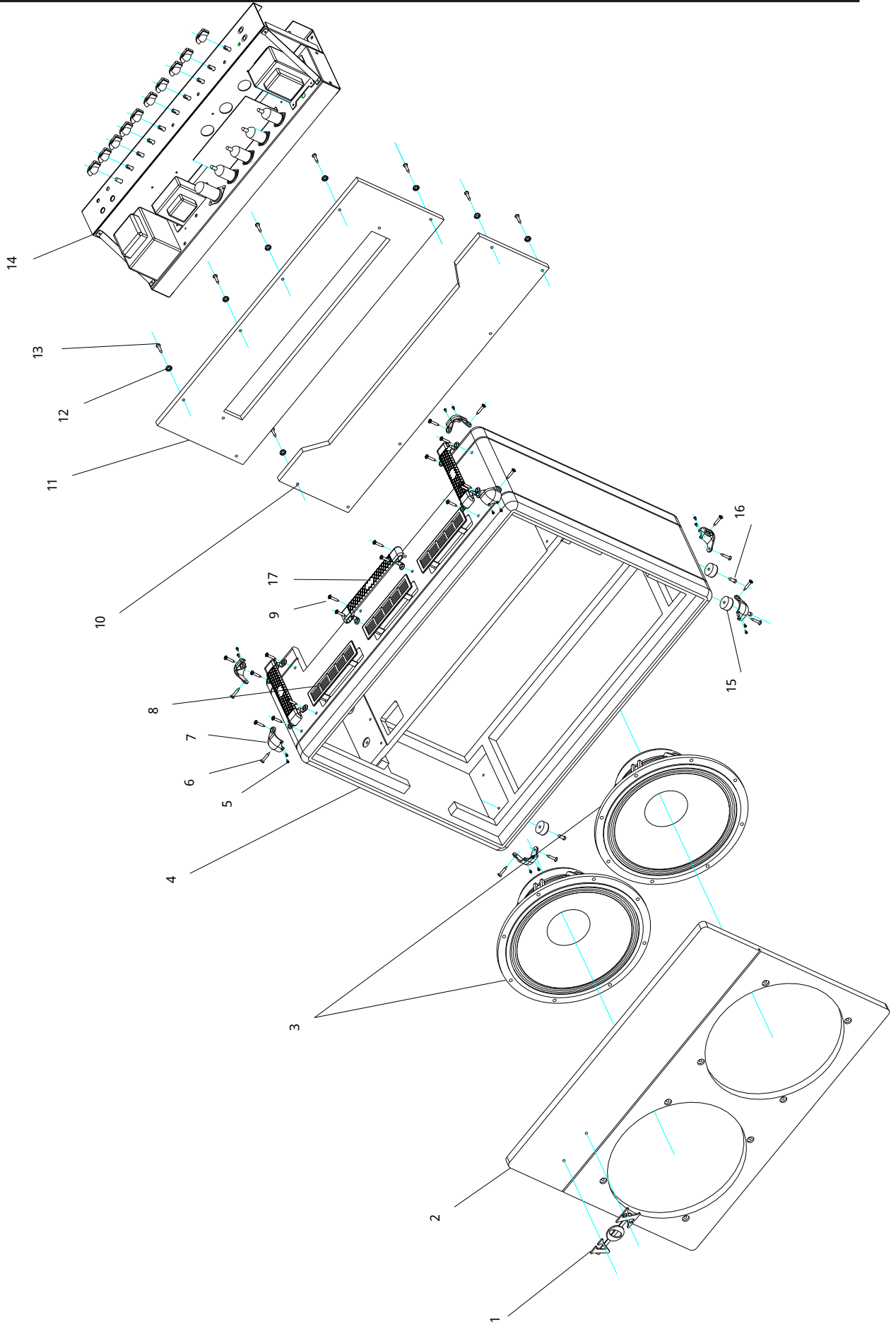

AC30CC2

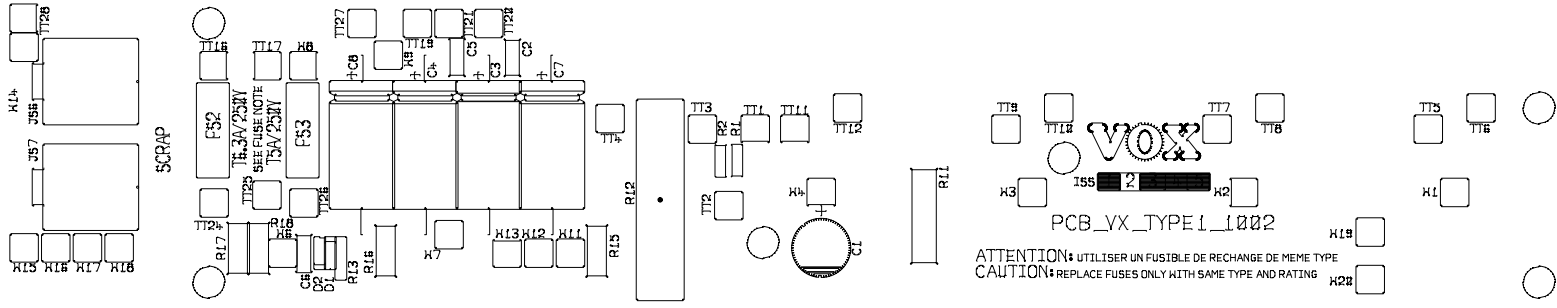

Amplifier pcb components location drawing

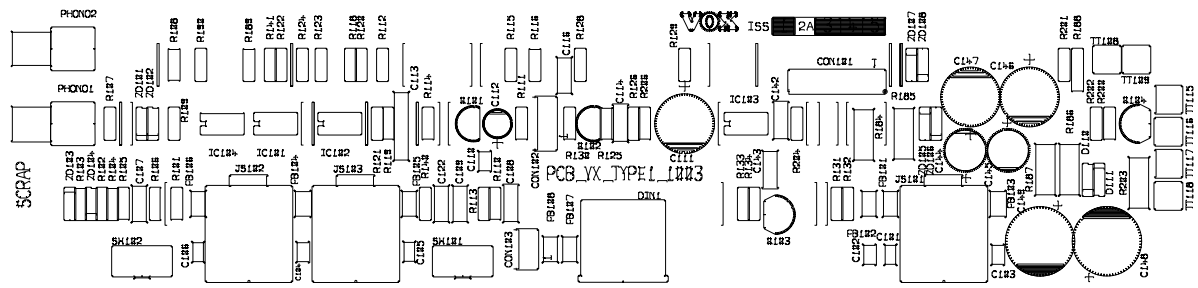

Input pcb component location diagram



AC30CC2

POTENTIOMER PCB COMPONENTS LOCATION DRAWING

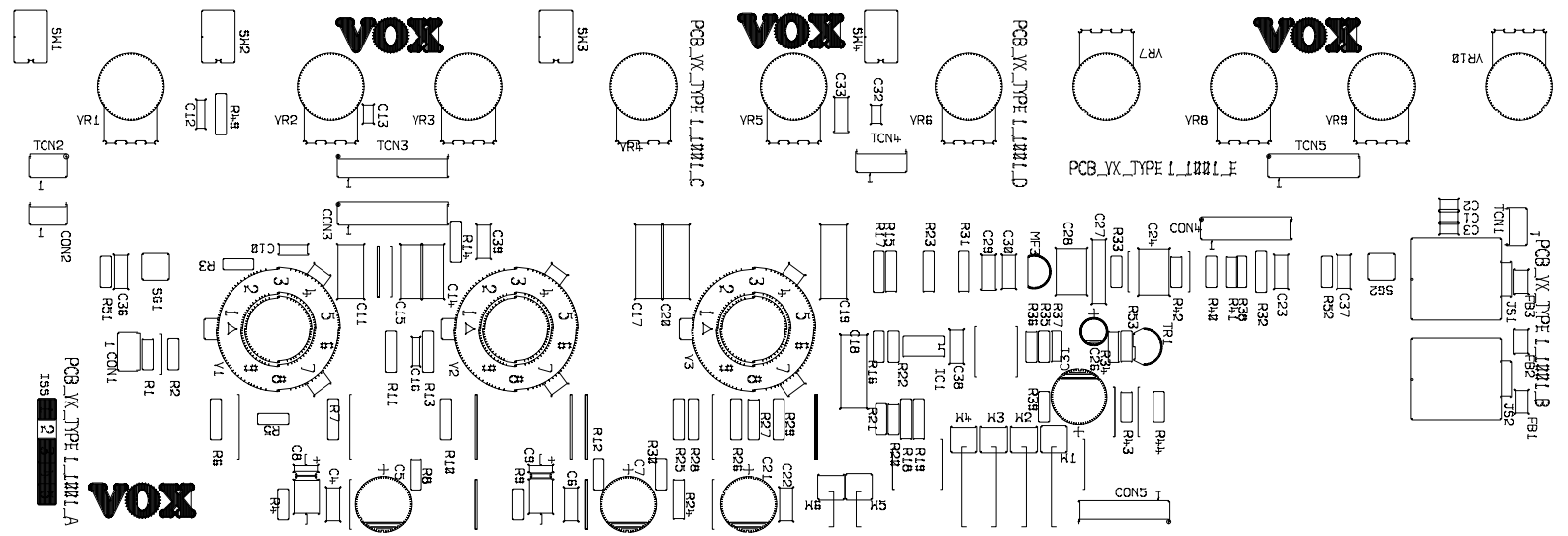

Prefix pcb location diagram

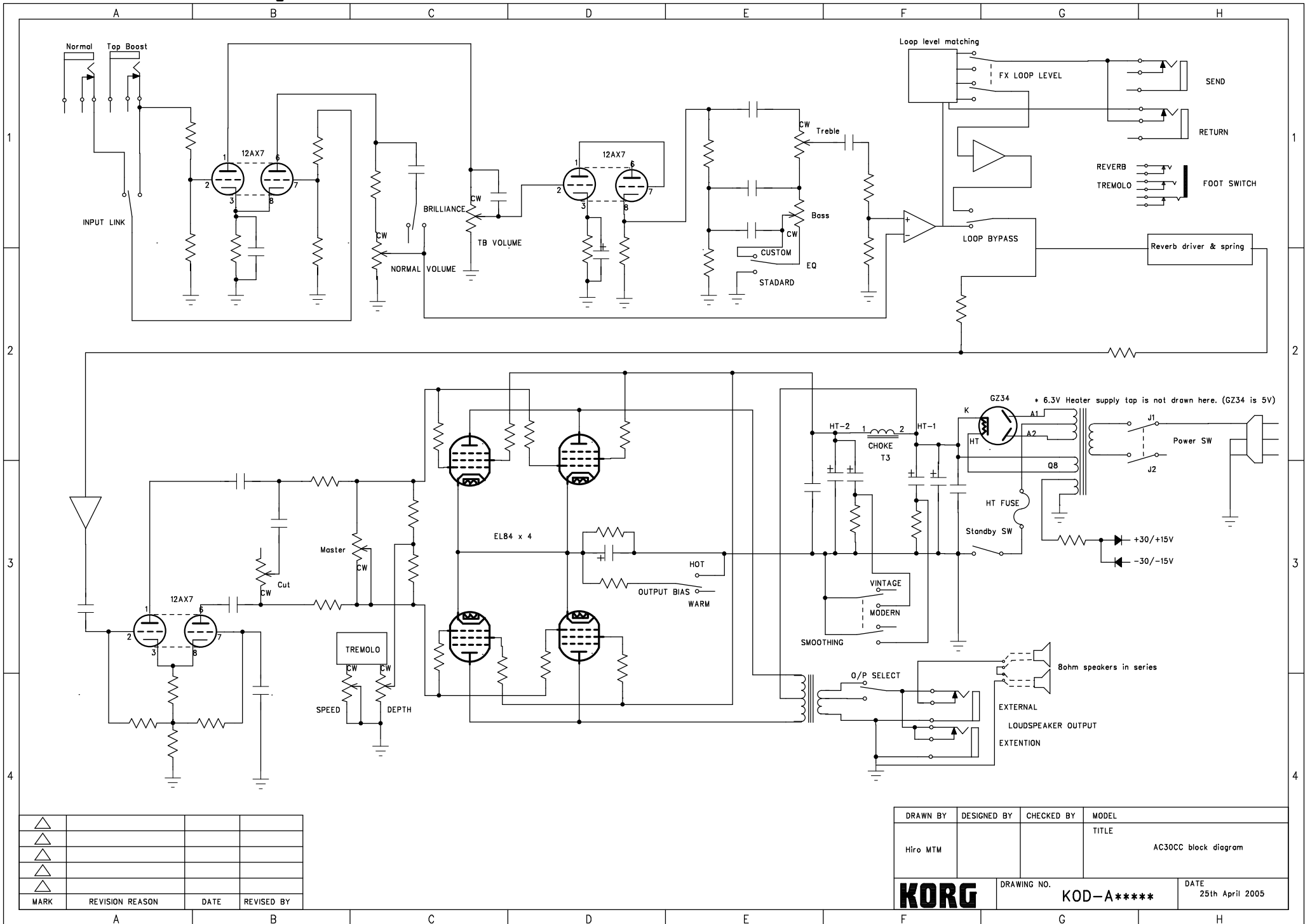

△			
△			
△			
△			
△			
MARK	REVISION REASON	DATE	REVISED BY

DRAWN BY	DESIGNED BY	CHECKED BY	MODEL
Hiro MTM			AC30CC block diagram
TITLE		DATE	
KORG		DRAWING NO. KOD-A****	25th April 2005

AC30CC2

ignoreLayers 7

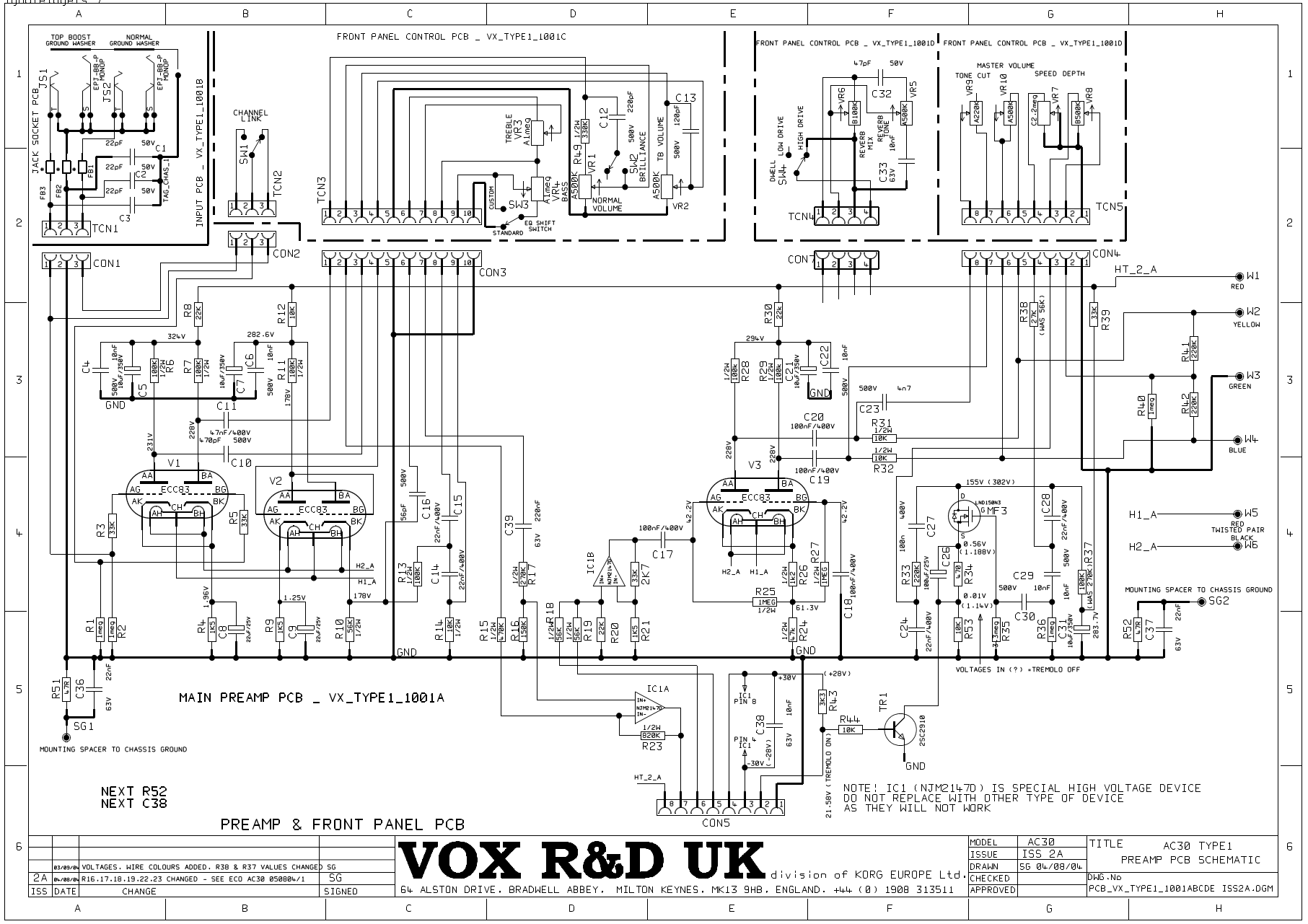

NEXT R52
NEXT C38

PREAMP & FRONT PANEL PCB

VOX R&D UK

division of KORG EUROPE Ltd.

MODEL	AC30
ISSUE	ISS 2A
DRAWN	SG 04/08/04
CHECKED	
APPROVED	

TITLE	AC30 TYPE1 PREAMP PCB SCHEMATIC
DWG.No	
PCB_VX_TYPE1_1001ABCDE ISS2A.DGM	

03/09/04	VOLTAGES - WIRE COLOURS ADDED. R38 & R37 VALUES CHANGED	SG
2A	R16,17,18,19,22,23 CHANGED - SEE ECO AC30 050804/1	SG
ISS	DATE	CHANGE
		SIGNED

64 ALSTON DRIVE, BRADWELL ABBEY, MILTON KEYNES, MK13 9HB, ENGLAND. +44 (0) 1908 313511

AC30CC2

ignore layers 7

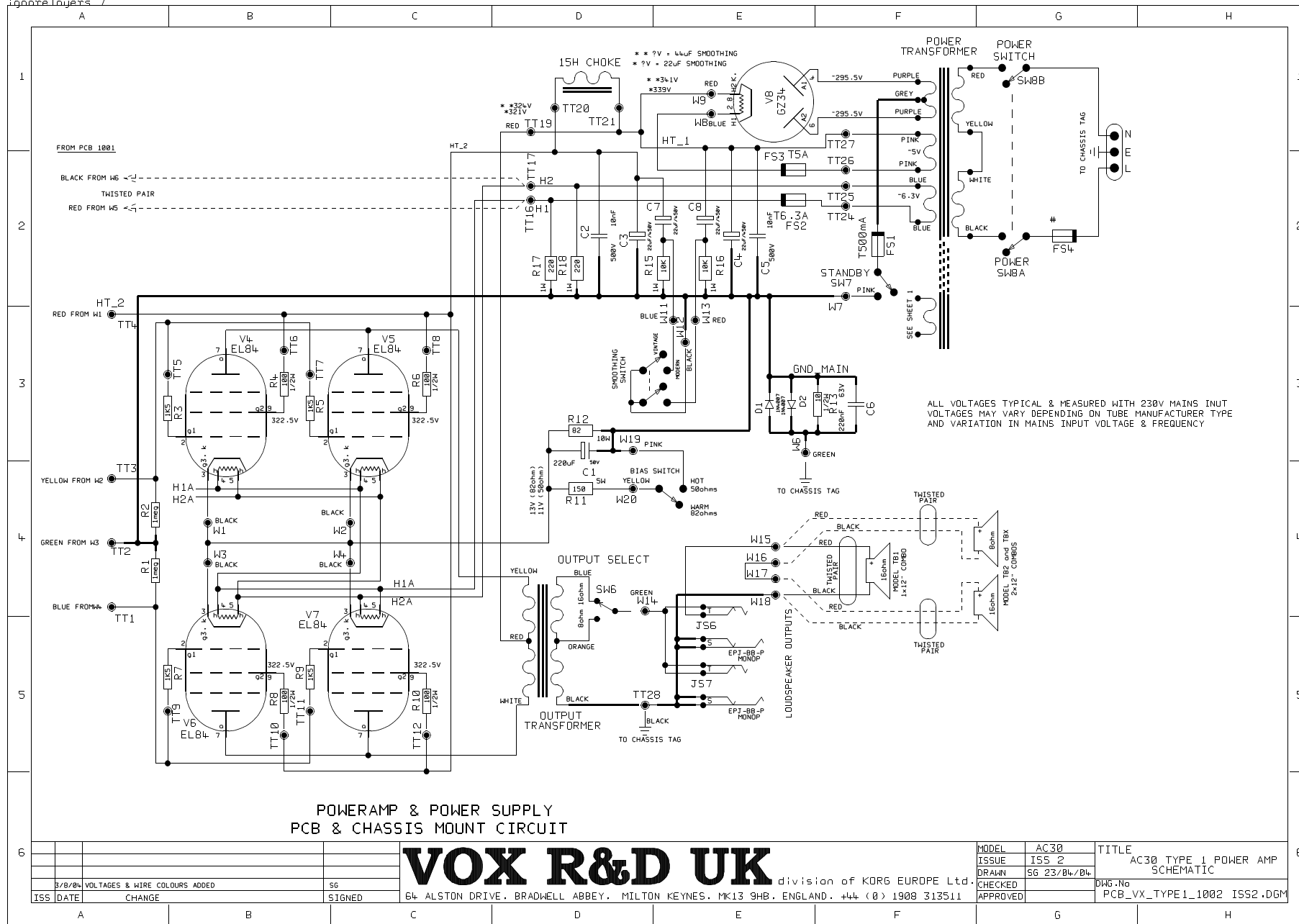

SCHEMATIC DIAGRAM (AMP)

POWERAMP & POWER SUPPLY
PCB & CHASSIS MOUNT CIRCUIT

VOX R&D UK

division of KORG EUROPE Ltd

MODEL	AC30	TITLE	AC30 TYPE 1 POWER AMP
ISSUE	ISS 2		SCHEMATIC
DRAWN	SG 23/04/04	DWG No	
CHECKED		PCB_VX_TYPE1_1002	ISS2.DGM
APPROVED			

ISS DATE	CHANGE	SIGNED
5/8/04	VOLTAGES & WIRE COLOURS ADDED	SG

64 ALSTON DRIVE, BRADWELL ABBEY, MILTON KEYNES, MK13 9HB, ENGLAND. +44 (0) 1908 313511

AC30CC2

SCHEMATIC DIAGRAM (AMP)

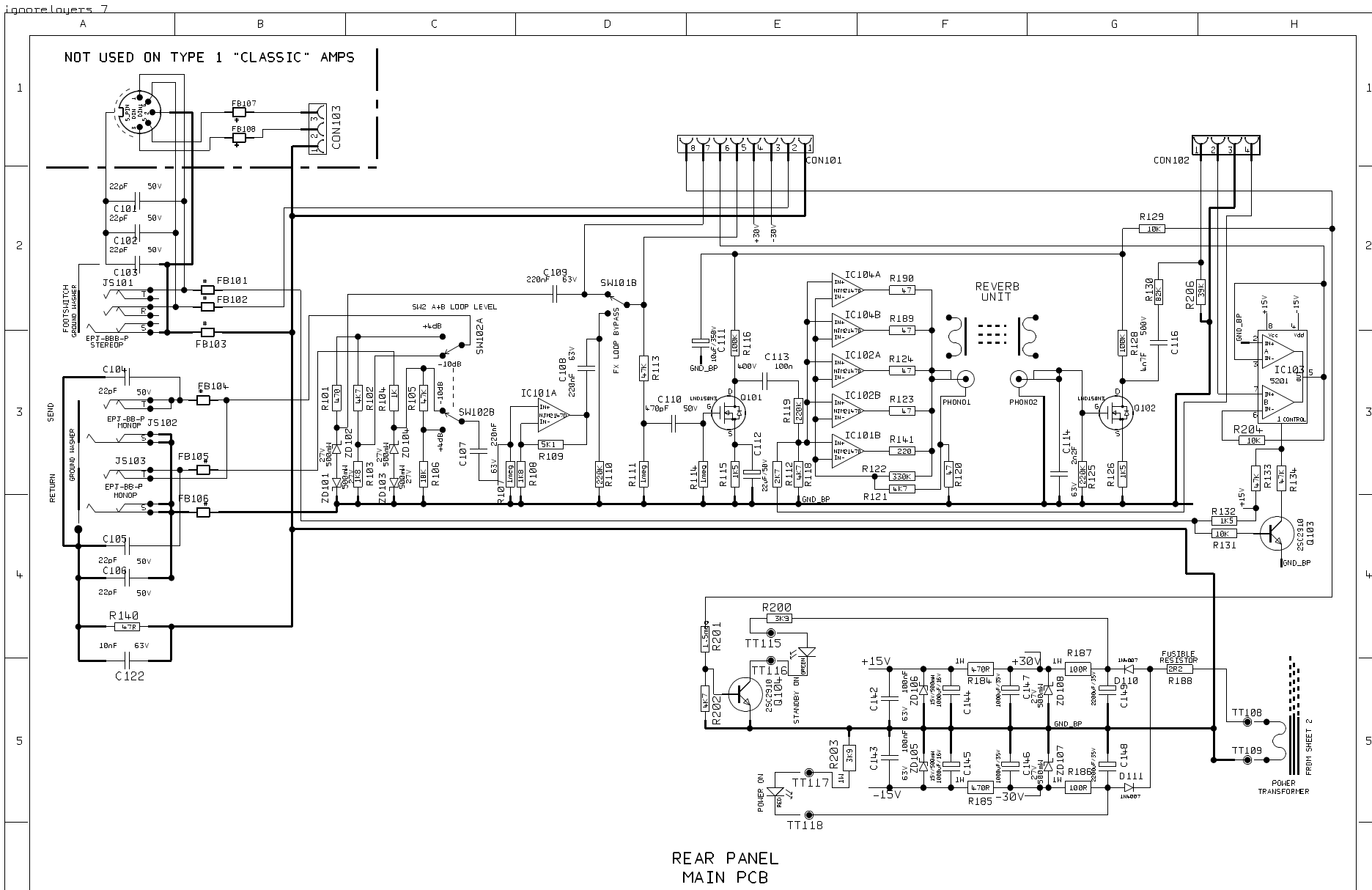

VOX R&D UK

division of KORG EUROPE Ltd
64 ALSTON DRIVE, BRADWELL ABBEY, MILTON KEYNES, MK13 9HB, ENGLAND. ++44 (0) 1909 313511

MODEL	AC30	TITLE	
ISSUE	ISS 2B	REAR PANEL I/O PCB SCHEMATIC	
DRAWN	S6 11/03/05	DWG No	PCB_VX_TYPE1_1003 ISS2B.DGM
CHECKED		APPROVED	

2B	11/03/05	PALL CHANGED FROM L7 TO ZD8 OHM TO PREVENT DISTORTION IN IC101A	SG
2	5/9/04	UP ISSUE LEGEND ADDED	SG
ISS DATE	CHANGE	SIGNED	

★ SCHEMATIC DIAGRAM(AMP)

AC30CC2

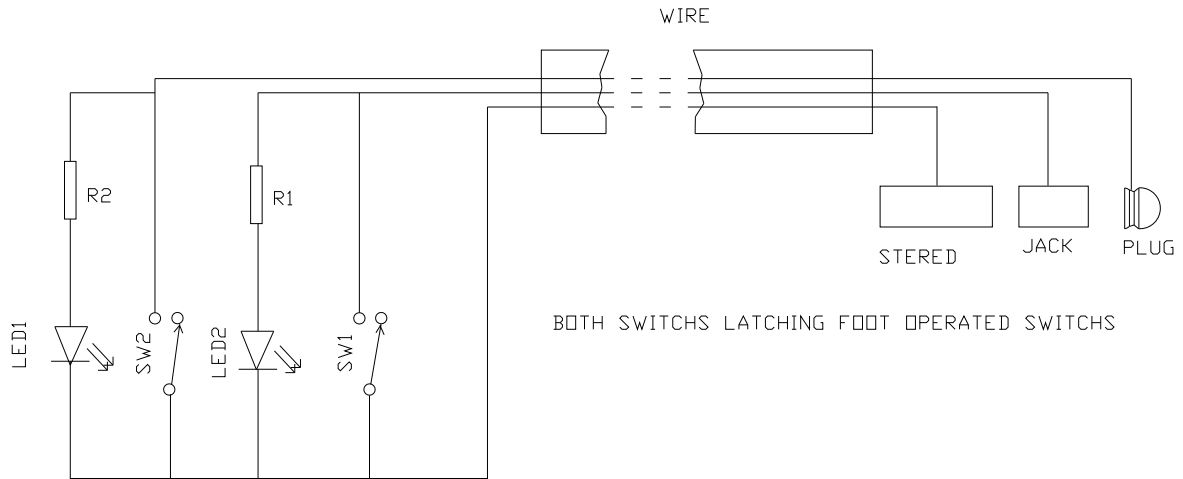

THE ASSEMBLY PARTS LIST AC30CC1

P/N	PART NAME	DESCRIPTION	QUA
550078-0300000000	REVERB	BL3EB3CIB	1
550084-2261100090	AUDIO CABLE	φ3.8MM L=1100MM	1
550217-1327000001	LOGO PLATE	KIMANSON SUPPLIED	1
550226-0250041311	RUBBER FOOT 1	φ25x12.5	4
550300-2003000011	FRONT PANEL for CC1	Black Vinyl / Grill Cloth/White Piping	1
550301-2003000011	BACKBOARD 1 for CC1	Black Vinyl	1
550301-2003000021	BACKBOARD 2 for CC1	Black Vinyl	1
550306-2321000001	VENT	ABS LXW=143x41	3
550308-2003000011	BOTTOM BOARD 1 for CC1	AMPLIFER UNDERPLAY BOARD	1
550308-2003000021	BOTTOM BOARD 2 for CC1	REVERB UNDERLAY BOARD	1
550328-1308000000	HANDLE	PVC	1
550344-2003000011	CABINET for CC1	Black Vinyl	1
550406-1308000000	PLASTIC CORNER	NYLON	8
550ZD-63900-01	LOUDSPEAKER for CC1	Celestion Neo Dog 12" 16ohm	1

THE ASSEMBLY PARTS LIST AC30CC2

P/N	PART NAME	DESCRIPTION	QUA
550078-0300000000	REVERB	BL3EB3CIB	1
550084-2261100090	AUDIO CABLE	φ3.8MM L=1100MM	1
550217-1327000001	LOGO PLATE	KIMANSON SUPPLIED	1
550226-0250041311	RUBBER FOOT 1	φ25x12.5	4
550226-1300000621	RUBBER FOOT 2		2
550300-2004000011	FRONT PANEL for CC2&CC2X	Black Vinyl / Grill Cloth/White Piping	1
550301-2004000011	BACKBOARD 1 for CC2&CC2X	Black Vinyl	1
550301-2004000021	BACKBOARD 2 for CC2&CC2X	Black Vinyl	1
550306-2321000001	VENT	ABS LXW=143x41	3
550308-2003000011	BOTTOM BOARD 1 for CC2&CC2	AMPLIFER UNDERPLAY BOARD	1
550308-2004000021	BOTTOM BOARD 2 for CC2&CC2	REVERB UNDERLAY BOARD	1
550328-1308000000	HANDLE	PVC	1
550344-2004000011	CABINET for CC2&CC2X	Black Vinyl	1
550406-1308000000	PLASTIC CORNER	NYLON	8
550ZD-53900-10	LOUDSPEAKER for CC2	Wharfedale GSH-120-8 12" 8 ohm	2

THE ASSEMBLY PARTS LIST AC30CC2X

P/N	PART NAME	DESCRIPTION	QUA
550078-0300000000	REVERB	BL3EB3CIB	1
550084-2261100090	AUDIO CABLE	φ3.8MM L=1100MM	1
550217-1327000001	LOGO PLATE	KIMANSON SUPPLIED	1
550226-0250041311	RUBBER FOOT 1	φ25x12.5	4
550226-1300000621	RUBBER FOOT 2		2
550300-2004000011	FRONT PANEL for CC2&CC2X	Black Vinyl / Grill Cloth/White Piping	1
550301-2004000011	BACKBOARD 1 for CC2&CC2X	Black Vinyl	1
550301-2004000021	BACKBOARD 2 for CC2&CC2X	Black Vinyl	1
550306-2321000001	VENT	ABS LXW=143x41	3
550308-2003000011	BOTTOM BOARD 1 for CC2&CC2	AMPLIFER UNDERPLAY BOARD	1
550308-2004000021	BOTTOM BOARD 2 for CC2&CC2	REVERB UNDERLAY BOARD	1
550328-1308000000	HANDLE	PVC	1
550344-2004000011	CABINET for CC2&CC2X	Black Vinyl	1
550406-1308000000	PLASTIC CORNER	NYLON	8
550ZD-65000-10	LOUDSPEAKER for CC2X	Celestion AlNiCo Blue	2

THE ASSEMBLY PARTS LIST AC30CCH

P/N	PART NAME	DESCRIPTION	QUA
550078-0300000000	REVERB	BL3EB3CIB	1
550084-2261100090	AUDIO CABLE	φ3.8MM L=1100MM	1
550217-1327000001	LOGO PLATE	KIMANSON SUPPLIED	1
550226-0250041311	RUBBER FOOT 1	φ25x12.5	4
550300-2006000011	FRONT PANEL for CCH	Black Vinyl / Grill Cloth/White Piping	1
550301-2006000011	BACKBOARD for CCH	Black Vinyl	1
550306-2321000001	VENT	ABS LXW=143x41	3
550308-2003000021	BOTTOM BOARD 2 for CCH	REVERB UNDERLAY BOARD	1
550308-2006000011	BOTTOM BOARD 1 for CCH	AMPLIFER UNDERPLAY BOARD	1
550328-1308000000	HANDLE	PVC	1
550344-2006000011	CABINET for CCH	Black Vinyl	1
550406-1308000000	PLASTIC CORNER	NYLON	8

FOOT SWICH PART LIST AC30CC1, CC2, CC2X & CCH

P/N	PART NAME	DESCRIPTION	QUA
550019-0311122001	DIODE	204HD/E-A RED φ3	2
550049-2102224111	JACK	PHONE JY6351-02-250	1
550060-2005000400	MICROPHONE CABLE	5M Microphone cable	1
550088-3210000501	DOUBLE FOOTPLATE	DOUBLE FOOTPLATE	1
550097-1201100000	FOOT SWICH	SF12020-0202-20R-L	2
550226-0160000821	RUBBER FOOT	RF-006	4
550302-2006000000	FOOT SWICH COVER	UPPER COVER	1

AMP ASSEMBLY PARTS LIST AC30CC1, CC2, CC2X & CCH

P/N	PART NAME	DESCRIPTION	QUA
550019-0511122000	AUDIO	RED 333HD/E-A	1
550019-0522122000	AUDIO	GREEN 333GD/E-A	1
550022-1000042212	OUTPUT TRANSFORMER		1
550022-2000062213	POWER TRANSFORMER	290V-25V-6.3V-5V	1
550043-0700000000	SWITCH	SC728	2
550044-2600000000	POWER JACK	RF-2004	1
550080-0150010000	INDUCTANCE	15H	1
550089-0600000022	SWICH	MS350 W1221S0022	3
550215-1308000000	KNOB	BLACK	10
550221-1009000091	LED JACKET	φ5LED JACKET	2
550300-2321000007	MAIN FRAME PANEL	Anodize panel	1
550301-1321000012	BACKBOARD		1
550302-1321000011	MAIN CHASSIS	1.6MM Aluminum	1
550308-0012000000	BRACKET	AL T=1.2	1
550309-2321000002	MINOR FRAME	T=1.6	1
550803-0030000000	RUBBER LOOP	GM-1A	1
550819-0004022000	RADIO TUBE	5AR4SOV	1
550819-0008422100	RADIO TUBE	EL84EH	4
550819-1200022000	RADIO TUBE	12AX7A	3
550820-0010000000	RADIO TUBE SOCKET	VT8-ST	1
550820-0070000000	RADIO TUBE SOCKET	G2C9-F	4

ELECTRONIC PARTS LIST AC30CC1, CC2, CC2X, CCH

P/N	PART NAME	DESCRIPTION	QUA
550017-3320000000	IC	NJM2120D	1
550017-3550000000	IC	NJM2147D	3
550018-0302910115	AUDION	2SC2910	1
550018-5415000115	AUDION	LND150N3	2
550020-1044111000	POTENTIOMETER	B100K AC30	1
550020-1054110000	POTENTIOMETER	A1M AC30	2
550020-2044110000	POTENTIOMETER	A200K AC30	1
550020-2254114000	POTENTIOMETER	C2.2M AC30	1
550020-5044110000	POTENTIOMETER	A500K AC30	4
550020-5044111000	POTENTIOMETER	B500K AC30	1
550031-2200513121	FUSE	51S050H	1
550031-2200515122	FUSE	TSD6.3A 5x20	1
550043-0306020600	SWTICH	SSSF122NAI-SII	2
550043-2003031100	SWITCH	MTS-102-A2 ON-ON	4
550049-1304113120	JACK 1	LS-2031-4	2
550049-1306223121	JACK 2	LS-2031-6	1
550051-5400000000	SOCKET 1	RED	1
550051-5500000000	SOCKET 2	WHITE	1
550055-0303095000	WIRE	3pin2.54mm L=95mm	1
550055-0304140000	WIRE	4pin2.54mm L=140mm	1
550055-0308070000	WIRE	8pin2.54mm L=70mm	1
550055-0310070000	WIRE	10pin2.54mm L=70mm	1
550056-4103221100	CONNECTOR JACK	DJ2802-3P	2
550056-4108000000	STICK	XH-8P	1
550056-4110000000	CONNECTOR JACK	10PIN 2.54	1
550060-0180100412	BLACK WIRE	AWG18# 1015 L=100MM	1
550060-0180130312	BLUE WIRE	AWG18# 1015 L=130MM	3
550060-0180540012	RED WIRE	AWG18# 1015 L=540MM	1
550060-0180540412	BLACK WIRE	AWG18# 1015 L=540MM	1
550067-2204007000	DIODE	1N4007	2
550067-3304744000	MANOSTAT	IN4744A 15V-1W	2
550067-3305254000	MANOSTAT	27V 1/2W IN5254	6
550088-3210000100	PREFIX AMP BOARD		1
550088-3210000110	INPUT CONNECT BOARD		1
550088-3210000111	LOUDSPEAKER OUTPUT BOARD		1
550088-3210000200	POTENTIOMER PCB BOARD		1
550088-3210000300	INPUT BOARD		1
550088-3210000400	AMPLIFIER BOARD		1
550820-0060000000	RADIO TUBE SOCKET	VT9-PT-2	3