

INDEXED PARTS LIST

DESCRIPTION	INDEX NO.	PART NO.	DESCRIPTION
BODY ASSEMBLY	23	09-3843-0	TAILPIECE ASSEMBLY
Acoustical Body (Specify Color)			
Electronic Cover (Plastic - 6-1/2" rd.)	24	09-136-0	Tailpiece Mtg. Screw (#6 x 1" Oval)
... Mtg. Screw (#3 x 3/8" rd.)		09-3844-0	Tailpiece Spindle (6 String)
Non-slip Pad (W/Snaps - 12")		09-3845-0	... Wood Panel Inlay (W/Logo)
Tap Button and Screw Assy. (Pad)			
Tap Button and Screw Assy.			
BACK GUARD			ELECTRONIC COMPONENTS
... Mtg. Screw & Spacer Assy.	25	09-3706-0	Distortion & Treble-Bass Boost Modules & P.C. Board Assy.
... Support Rod Spacer & Screw Assy.		09-3707-0	... Treble-Bass Boost Module
... Support Rod		09-3708-0	... Distortion Module
... Support Rod Mtg. Bracket & Spacer Assy.		09-3709-0	... P.C. Board (Only)
... Support Rod Bracket Mtg. Screw		09-3710-0	... 100 uF 12V (Electro.) Capacitor
		09-3711-0	... 10 uF 15V (Electro.) Capacitor
	26	66-5000-0	9V Transistor Battery
	27	09-3842-0	Battery Clamp & Screw Assy.
		09-6202-0	... Battery Clip & Cable Assy.
BACK ASSEMBLY W/MACHINE HEADS	28	09-3703-0	"E" Tuner Assy.
... Mtg. Screw (#10 x 2" Oval)		09-3704-0	... Tuning Coil
Machine Head (Single)		09-3705-0	... P.C. Board (Only)
... Mtg. Screw (#2 x 5/8" Oval)	29	09-1027-0	100k Ohm Linear Pot. (Tone)
Machine Head Eyelet (rd.)	30	09-3719-0	Knob (Tone I)
String Cleat, Spacer & Screw Assy.	31	09-3716-0	.094 uF 125V Capacitor
Bridge Nut (Aluminum)	32	09-1028-0	500k Ohm Log. Pot. (Volume)
Ret Wire (Narrow - Order Per Foot)	33	09-3720-0	Knob (Volume I)
Ret Wire (Wide - Order Per Foot)	34	09-3714-0	1.5k Ohm Pot. (Distortion)
Serial Number Plate (1-5/8" x 2-5/8")	35	09-3721-0	Knob (Distortion)
... Mtg. Screw (#10 x 2" Oval)	36	09-3715-0	500k Ohm "B" Pot. (TR-B Boost)
	37	09-3722-0	Knob (TR-B Boost)
		09-3718-0	Set Screw (All Knobs)
ADJUSTABLE BRIDGE ASSEMBLY	38	09-3702-0	Pickup Assy.
Bridge Stand (Wood)	39	09-3847-0	Mtg. Bracket (Plastic)
... Bridge Adjustment Nut (Chrom.)		09-3712-0	... Pickup Adjusting Screw & Spring Assy.
Bridge Cover	40	09-3029-0	Phono Jack (Stereo)
	41	09-3846-0	Control & Switch Plate (W/Mtg. Screws)
	42	09-3717-0	Dial Pointer
	43	09-3713-0	Slide Switch

GUITAR

SERVICE INFORMATION



© 1968



APOLLO

V266

MARCH R

Thomas Organ Company • National Service Department • Sepulveda, California

Printed in U.S.A.

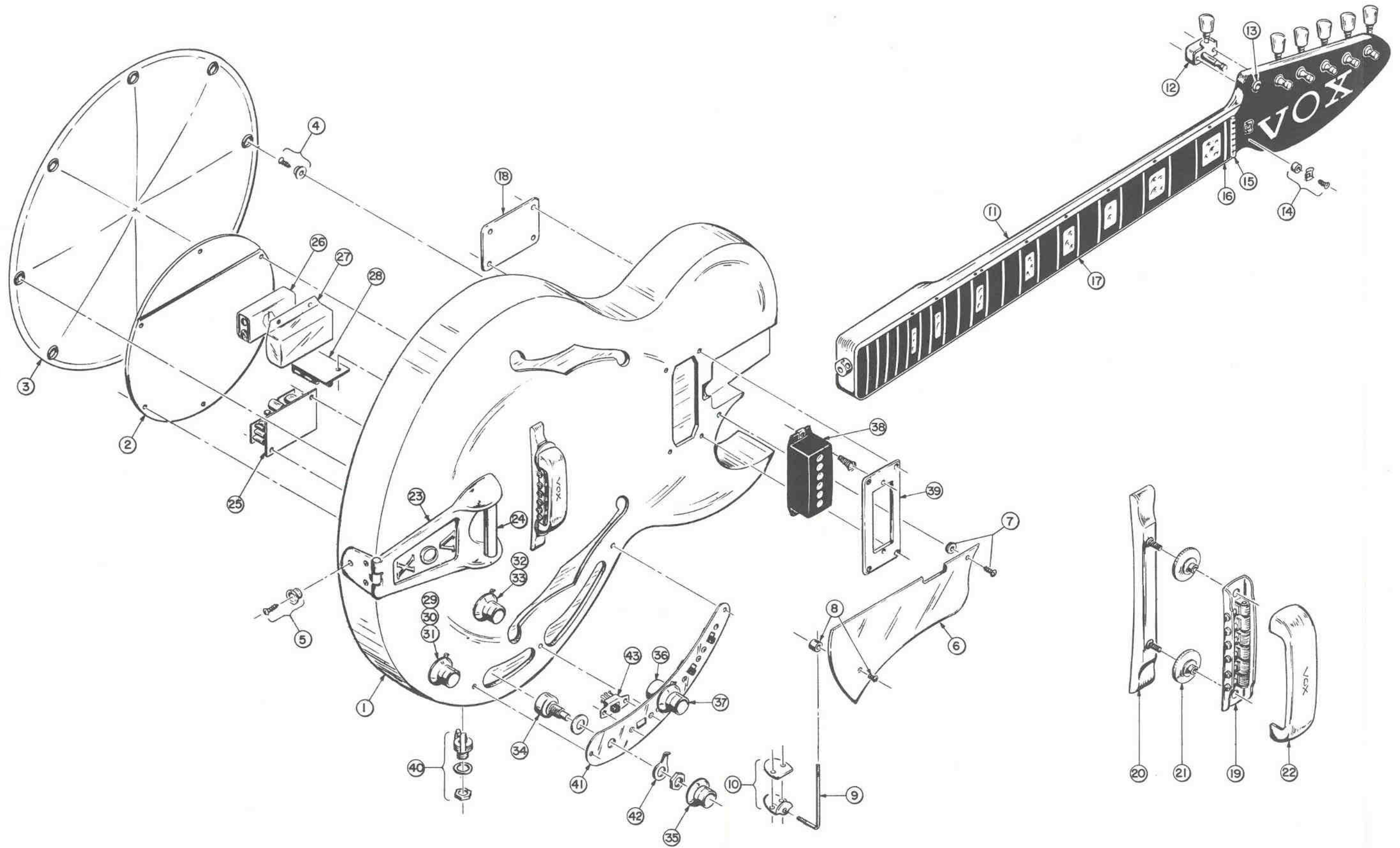

INDEX NO.	PART NO.
1	09-
2	09-
3	09-
4	09-
5	09-
6	09-
7	09-
8	09-
9	09-
10	09-
11	09-
12	09-
13	09-
14	09-
15	09-
16	09-
17	09-
18	09-
19	09-
20	09-
21	09-
22	09-

38-5648-0

WIRING DIAGRAM

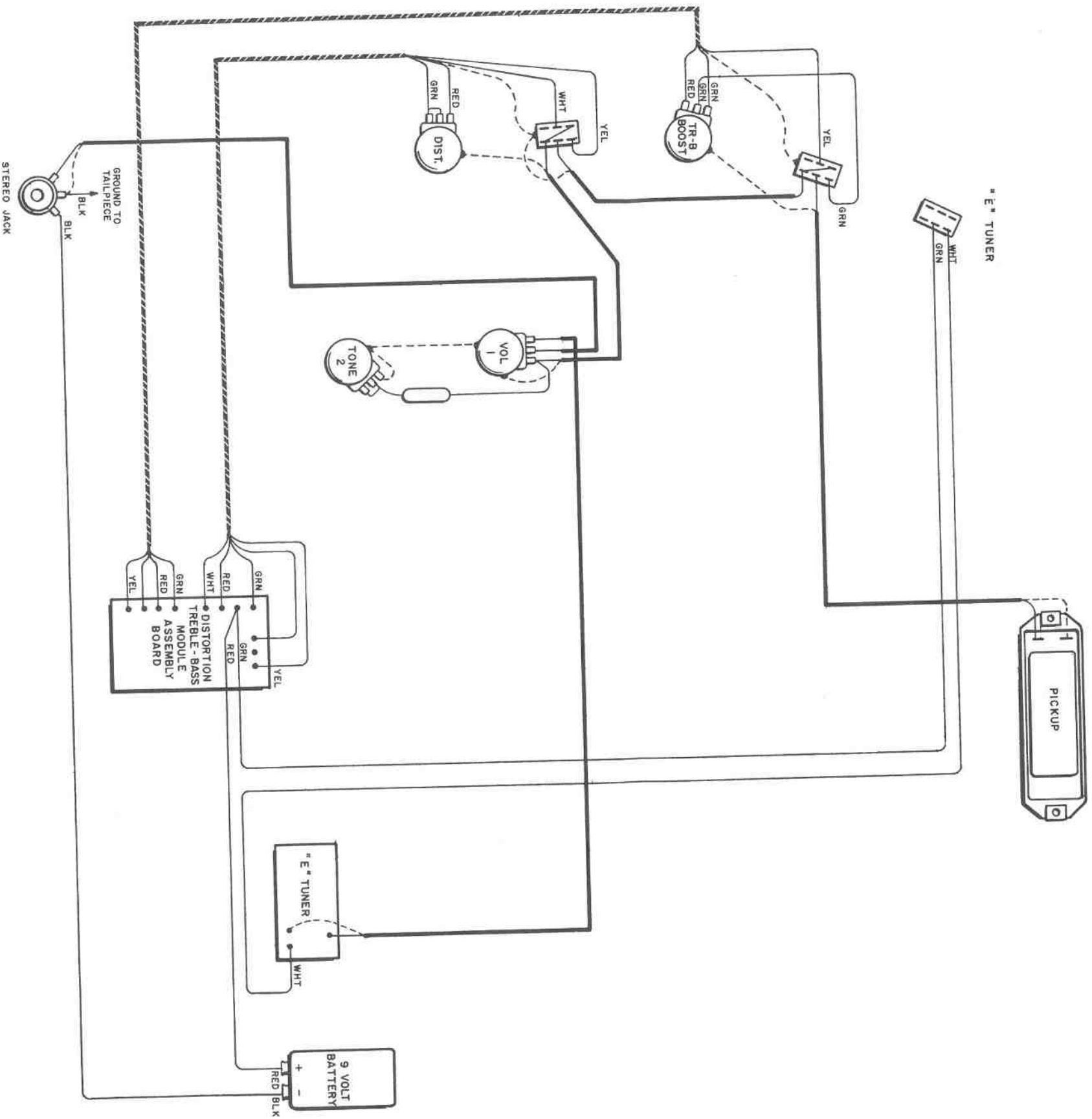

LEGEND

- SINGLE WIRE
- SHIELDED CABLE
- CABLE
- GROUND